

CLUTCH

GROUP 12

INDEX

DESCRIPTION	12-2	CLUTCH UNIT REMOVAL AND INSTAL-	
HYDRAULIC CONTROL	12-5	LATION (intervention on vehicle)	12-11
Pedal	12-5	Removal	12-11
Clutch master cylinder	12-5	Installation	12-12
Clutch operating cylinder	12-5	CLUTCH UNIT OVERHAUL AT BENCH	12-13
Hydraulic system piping	12-7	Single-plate clutch with "pushed"	
HYDRAULIC SYSTEM BLEEDING	12-8	diaphragm spring	12-16
REMOVAL AND INSTALLATION OF		Single-plate clutch with "drawn"	
CLUTCH-SPEED GEAR DIFFERENTIAL		diaphragm spring	12-22
UNIT	12-8	Double-plate clutch	12-28
SEPARATION AND RECONNECTION AT		SERVICE DATA AND SPECIFICATIONS	12-32
BENCH OF CLUTCH UNIT FROM/TO		General specifications	12-32
SPEED GEAR AND DIFFERENTIAL		Checks and Adjustments	12-34
UNITS	12-9	Tightening torques	12-37
Separation	12-9	TROUBLE DIAGNOSIS AND CORREC-	
Reconnection	12-10	TIVE ACTIONS	12-38
		SPECIAL SERVICE TOOLS	12-40

CLUTCH

DESCRIPTION

- The clutches used (single-plate or double-plate type according to motorization) are of the hydraulic control type with automatic taking-up.
- Clutch disengagement is realized by means of the special master cylinder which, operated by clutch pedal transmits the pressure increase of system (supplied by the clutch and

brake fluid tank) to piston of operating cylinder (8).

This last, through push rod (9) operates on clutch disengagement fork (11) which moves thrust bearing (13) and wins diaphragm spring (15) action with consequent backing of driven plate (plates) (14) and clutch disengagement.

- The peculiarity of the hydraulic con-

trol is that of keeping thrust bearing (13) in contact with diaphragm spring (15) of pressure plate body (16), independently of driven plate (plates) wear degree, thus realizing taking-up in an automatic and progressive way. As a consequence, no adjustment is required for the clutch.

Single-plate clutch with
"pushed" diaphragm spring

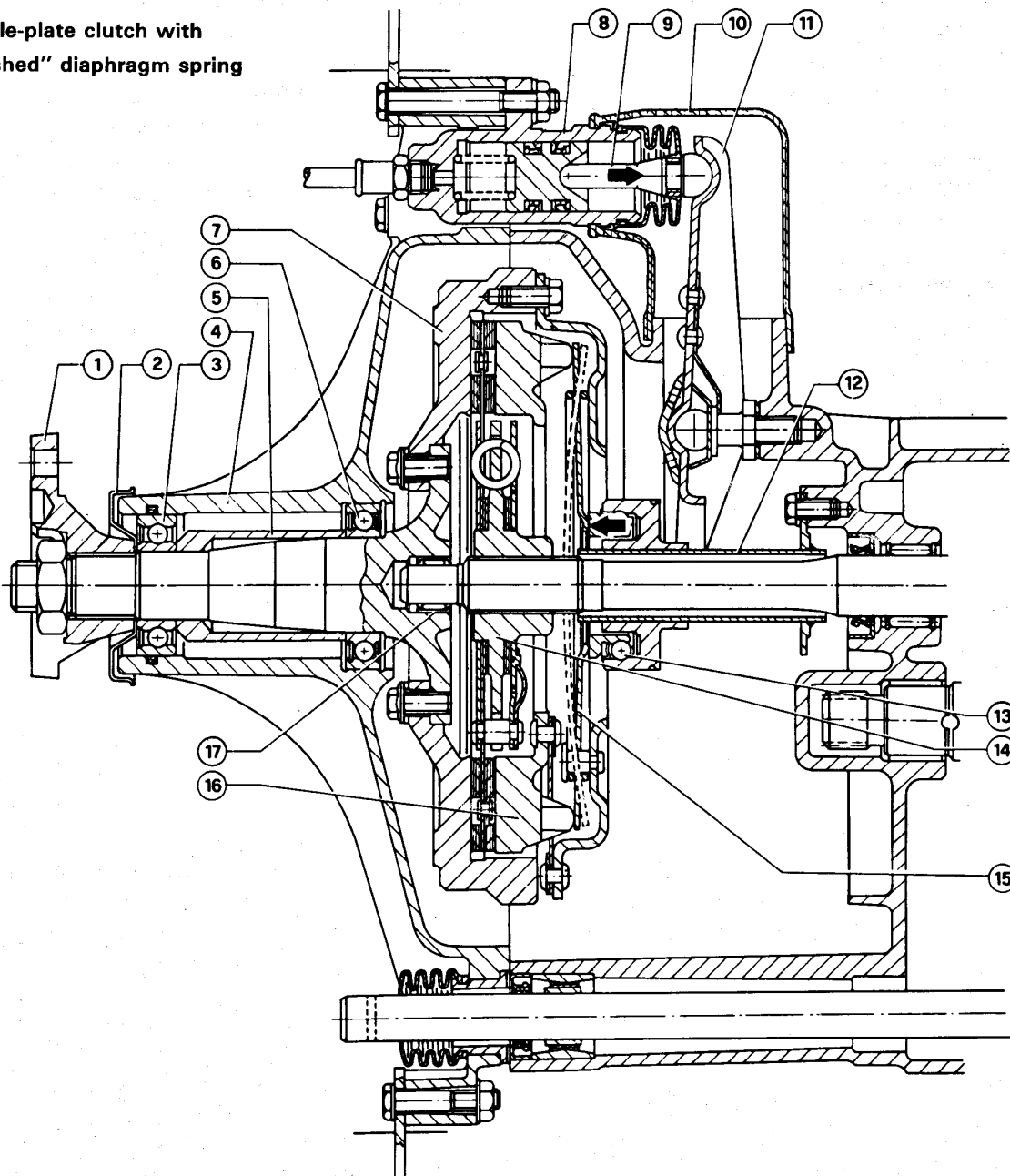

CLUTCH

Single-plate clutch with "drawn" diaphragm spring

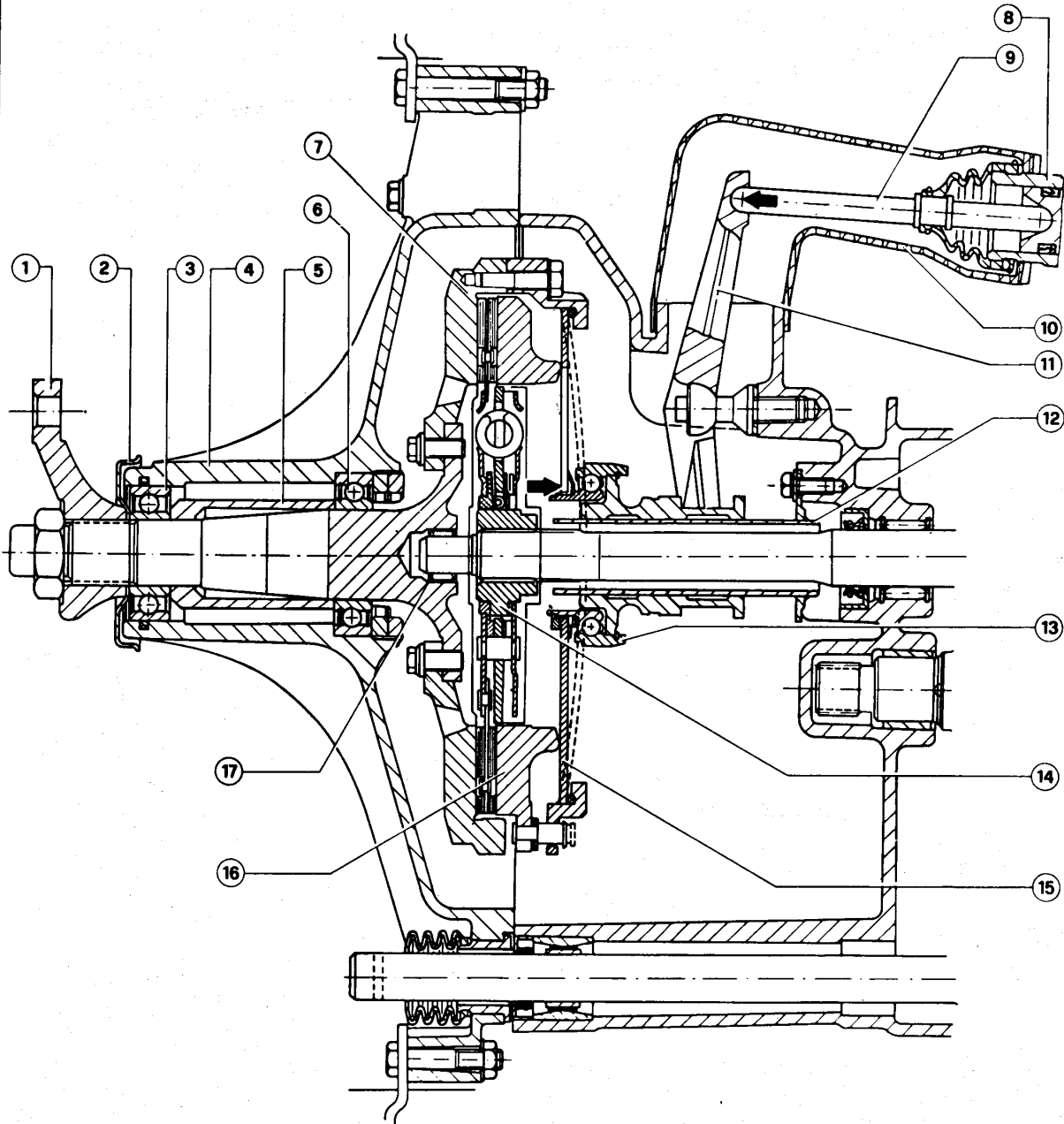

- 1 Propeller shaft connection fork
- 2 Dust cover
- 3 Clutch shaft support front bearing
- 4 Clutch cover
- 5 Spacer
- 6 Clutch shaft support rear bearing
- 7 Clutch flywheel
- 8 Clutch operating cylinder
- 9 Push rod

- 10 Guard
- 11 Clutch disengagement fork
- 12 Sleeve
- 13 Thrust bearing
- 14 Driven plate
- 15 Diaphragm spring
- 16 Pressure plate body
- 17 Speed gear main shaft centering needle bearing

CLUTCH

Double-plate clutch

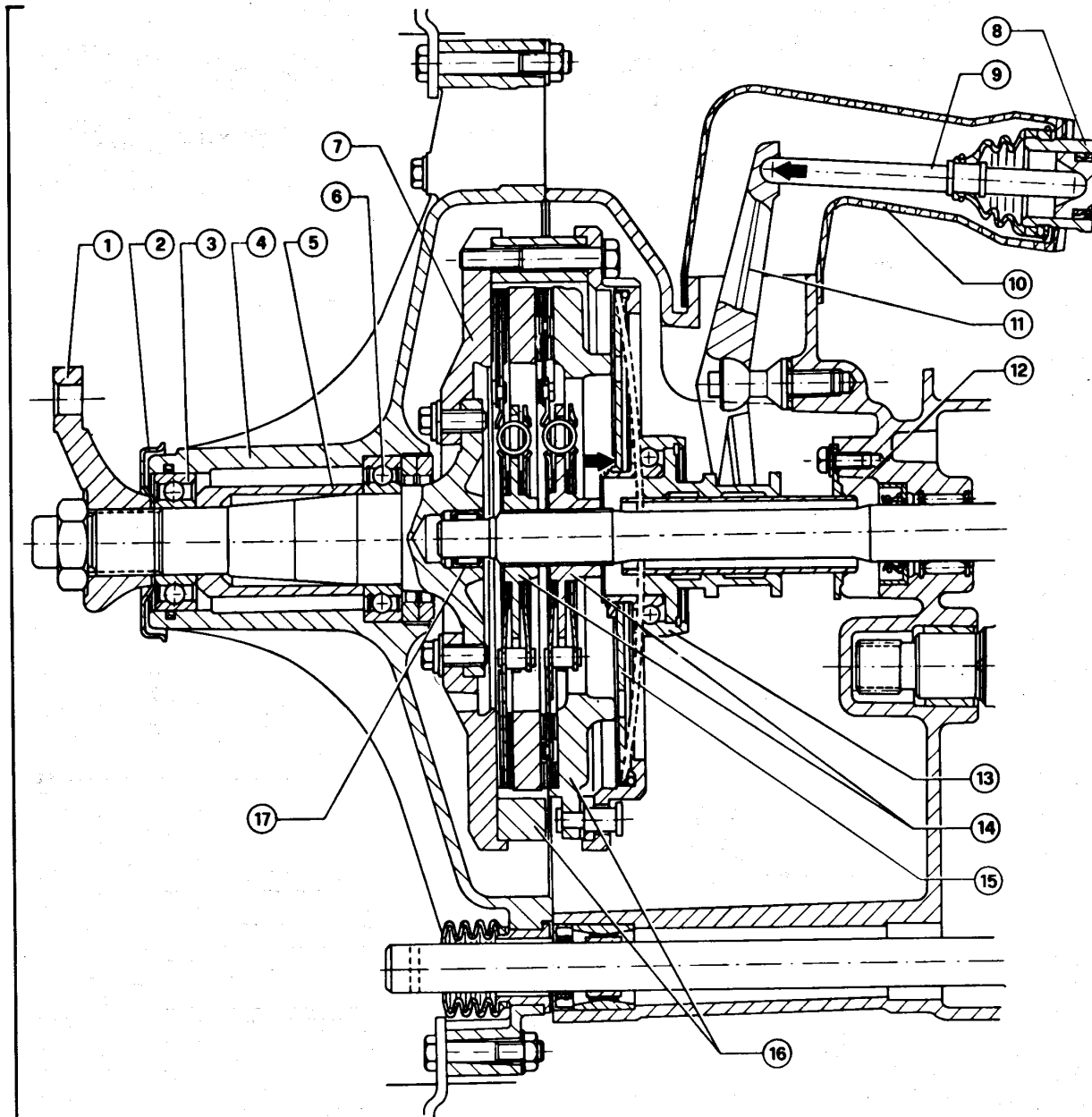

- 1 Propeller shaft connection fork
- 2 Dust cover
- 3 Clutch shaft support front bearing
- 4 Clutch cover
- 5 Spacer
- 6 Clutch shaft support rear bearing
- 7 Clutch flywheel
- 8 Clutch operating cylinder
- 9 Push rod

- 10 Guard
- 11 Clutch disengagement fork
- 12 Sleeve
- 13 Thrust bearing
- 14 Driven plates
- 15 Diaphragm spring
- 16 Pressure plates bodies
- 17 Speed gear main shaft centering needle bearing

CLUTCH

HYDRAULIC CONTROL

PEDAL

For clutch pedal removal procedure, refer to Group 22 - Front and Rear Brakes - Pedals - Removal.

CLUTCH MASTER CYLINDER

REMOVAL

1. Operating from engine compartment, remove plug from brake and clutch system supply tank, then drain fluid until level is below master cylinder supply hose.
2. Unscrew the screws securing windshield washer liquid tank to body and move tank sideways.
3. Detach hose ① from clutch master cylinder ②.
4. Unscrew union of pipe ③ and disconnect it from master cylinder.

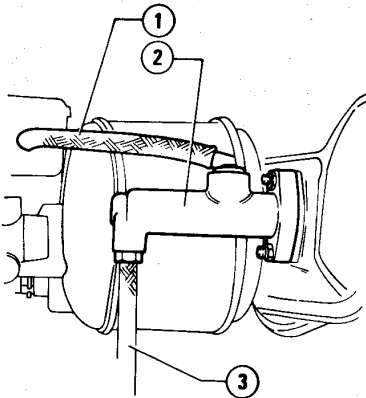

- 1 Master cylinder supply hose
- 2 Clutch master cylinder
- 3 Clutch control pipe

5. Operating from vehicle inside, remove split pin ① and withdraw pin ② then detach pedal ③ from fork ④.
6. Remove cup ⑤ and recover spring ⑥.

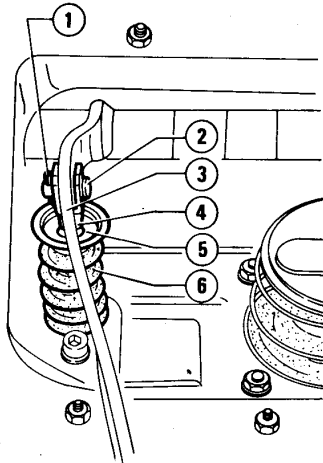

- 1 Split pin
- 2 Pin
- 3 Clutch pedal
- 4 Clutch master cylinder control fork
- 5 Cup
- 6 Spring

7. Unscrew the two screws securing master cylinder to pedals casing and remove master cylinder by withdrawing it from engine compartment.

INSTALLATION

To install clutch master cylinder, reverse the order of removal and comply with the following.

- Tighten to the prescribed torques

Ⓣ: Tightening torques

Clutch hydraulic system pipe unions

8 to 10 N·m
(0.8 to 1 kg·m
5.8 to 7.2 ft·lb)

Clutch hydraulic system hose unions

10 to 15 N·m
(1 to 1.5 kg·m
7.2 to 10.8 ft·lb)

- Restore tank level making use of the fluid prescribed.

Clutch hydraulic system fluid

ATE "Blau S"

or

AGIP Brake Fluid Super HD

or

IP Auto Fluid FR

- Carry out air bleeding from clutch hydraulic system (refer to: "Hydraulic System Bleeding").

CLUTCH OPERATING CYLINDER

REMOVAL (INTERVENTION ON VEHICLE)

Single-plate clutch with "pushed" diaphragm spring

1. Disconnect hose ① from bracket on body and plug it suitably.
2. Unscrew the two screws securing operating cylinder ③ to clutch box ②, then remove it together with guard.

CLUTCH

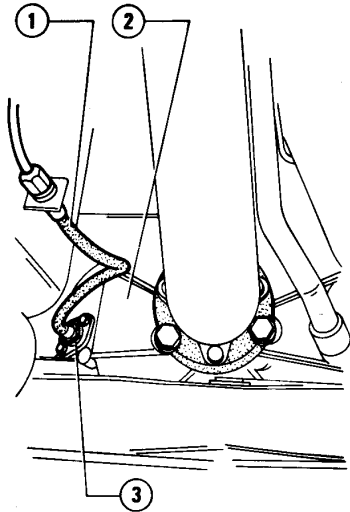

- 1 Operating cylinder control hose
- 2 Clutch box
- 3 Clutch operating cylinder

Single-plate clutch with "drawn" diaphragm spring and double-plate clutch

- 1 Disconnect hose (1) from bracket on body and plug it suitably.
- 2 Remove ring (3) on operating cylinder body.
- 3 Remove guard (4) and withdraw clutch control fork.
- 4 Remove operating cylinder from bracket (5).

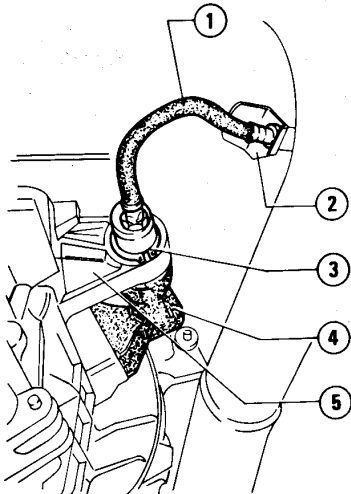

- 1 Clutch hose
- 2 Bracket
- 3 Retaining ring
- 4 Guard
- 5 Support bracket

DISASSEMBLY

1. Remove the following items from operating cylinder (4): push rod (9) with guard (8), piston (7) with seal rings (6), and spring (5).
2. Withdraw push rod from guard and remove bleeder screw (2).

Single-plate clutch with "pushed" diaphragm spring

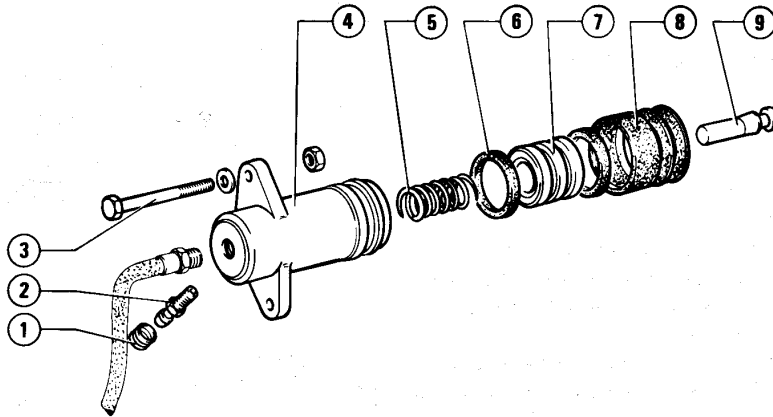

Single-plate clutch with "drawn" diaphragm spring and double-plate clutch.

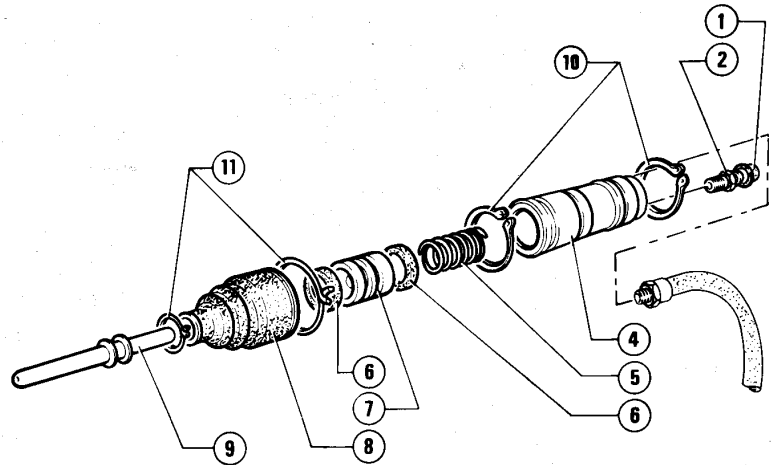

- 1 Bleeder screw cap
- 2 Bleeder screw
- 3 Bolt securing operating cylinder to clutch cover
- 4 Operating cylinder
- 5 Spring
- 6 Seal ring
- 7 Piston
- 8 Guard
- 9 Push rod with spherical pin
- 10 Retaining rings
- 11 Securing springs

CLUTCH

CHECKS AND INSPECTIONS

Visually check the disassembled components and replace the worn or damaged ones, supplied in the spare part kit.

CAUTION:

Wash all components of operating cylinder using suitable fluid. Do not use gasoline, kerosene or mineral oils in order not to damage the rubber parts of hydraulic system.

1. Check for scratches and rust on piston and inside clutch operating cylinder.
2. Check spring efficiency and integrity of seal rings.
3. Verify that bleeder hole is free from impurities.

REASSEMBLY

Reassemble the clutch operating cylinder by reversing the order of disassembly.

INSTALLATION

For installation, reverse the order of removal and comply with the following.

- Tighten the hydraulic system hose union to support bracket pipe to the prescribed torque.

T: Tightening torques
Unions of clutch hydraulic system hoses

10 to 15 N·m
(1 to 1.5 kg·m
7.2 to 10.8 ft·lb)

Unions of clutch hydraulic system pipes

8 to 10 N·m
(0.8 to 1 kg·m
5.8 to 7.2 ft·lb)

- Carry out system bleeding (refer to: "Hydraulic System Bleeding").

HYDRAULIC SYSTEM PIPING

CHECKS AND INSPECTIONS

Visually check system piping integrity. Replace damaged parts. In the event of fluid leaks from unions, if due to loosening, tighten them and, if necessary, replace the damaged components.

DISASSEMBLY

1. Remove the top-up plug on supply tank and drain the fluid by means of a syringe.
2. Loosen securing nuts of pipe connecting master cylinder to clutch operating cylinder; then remove pipe.

REASSEMBLY

1. Reassemble piping on vehicle by reverse the order of disassembly.
2. Tighten unions to the prescribed torque.

T: Tightening torques
Unions of clutch hydraulic system hoses

10 to 15 N·m
(1 to 1.5 kg·m
7.2 to 10.8 ft·lb)

Unions of clutch hydraulic system pipes

8 to 10 N·m
(0.8 to 1 kg·m
5.8 to 7.2 ft·lb)

3. Restore correct fluid level into tank, then bleed air from hydraulic system (refer to: "Hydraulic System Bleeding").

CLUTCH

HYDRAULIC SYSTEM BLEEDING

CAUTION:

The clutch hydraulic system must be bled whenever hydraulic system has been disconnected or air has entered it.

Carefully comply with the following procedure:

1. Remove plug of brake and clutch hydraulic system supply tank and, if necessary, restore level with the prescribed fluid.

Fluid for clutch hydraulic system

ATE "Blau S"

or

AGIP Brake Fluid Super HD

or

IP Auto Fluid FR

2. Remove bleeder screw cap on operating cylinder and fit a hose on it dipping hose ends into a transparent tank fitted with system fluid.
3. At the same time, loosen bleeder screw and press clutch pedal up to end of travel, then release it slowly; repeat this operation until all possible air bubbles have been ejected.

4. With clutch pedal pressed to end of travel, close the bleeder screw, remove hose and install cap.
5. Restore fluid level into tank and install the related plug.

CAUTION:

- a. Do not re-use the hydraulic fluid drained during bleeding operations.
- b. Operate carefully in order to prevent hydraulic fluid from getting in contact with paint, with consequent damage of paint itself.
- c. During bleeding operation, fluid level in the tank, must be kept above the min. mark.

6. Verify that clutch disengagement and speeds engagement takes place properly.

If necessary, verify travel of operating cylinder push rod.

This travel can not be adjusted and depends on the volume of fluid moved by the clutch master cylinder piston.

Single-plate with "pushed" diaphragm spring:

C = 11 to 12.7 mm
(0.43 to 0.50 in)

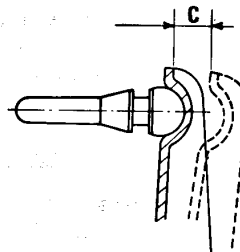

Single-plate with "drawn" diaphragm spring:

C = 12.5 mm
(0.49 in)

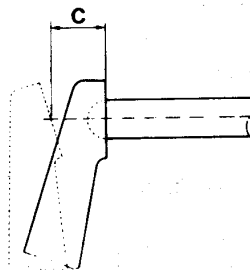

7. If "c" stroke value is not as specified, check efficiency of control hydraulic system.

REMOVAL AND INSTALLATION OF CLUTCH-SPEED GEAR-DIFFERENTIAL UNIT

Refer to: Group 17 - "Removal and Installation of Clutch Speed Gear-Differential Unit."

SEPARATION AND RECONNECTION AT BENCH OF CLUTCH UNIT FROM/TO SPEED GEAR AND DIFFERENTIAL UNITS

SEPARATION

Set the clutch-speed gear-differential unit on a suitable turning stand (refer to: Group 17 - "Removal and Installation of Clutch-Speed Gear-Differential Unit") then proceed to clutch unit removal operation.

SINGLE-PLATE CLUTCH WITH "PUSHED" DIAPHRAGM SPRING

1. Clutch unit disassembly.
 - a. Remove pin (3) from rod (2) and withdraw lever (4).

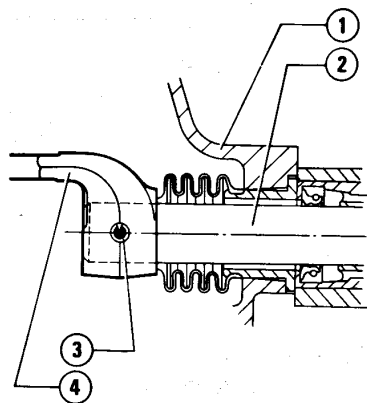

- 1 Clutch box
- 2 Speed gear engagement and selection rod
- 3 Spring pin
- 4 Lever

- b. Loosen and remove the screws securing clutch unit to clutch-speed gear casing.

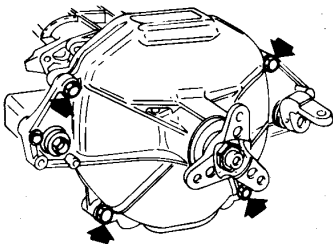

- c. Withdraw clutch unit (3) from shaft (2) and remove cap (4).

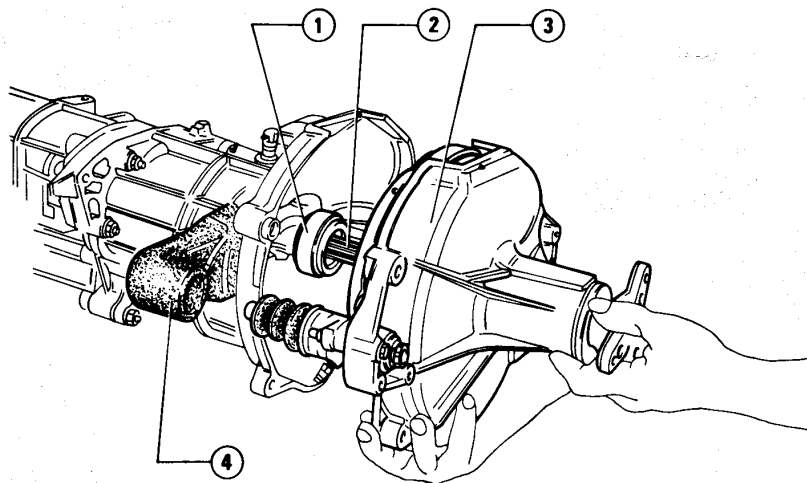

- 1 Thrust bearing
- 2 Main shaft
- 3 Clutch unit
- 4 Fork control cylinder cap

2. Fork and thrust bearing
 - a. Withdraw thrust bearing (4) from sleeve (3).
 - b. Remove fork (1) by releasing it from pin (2).

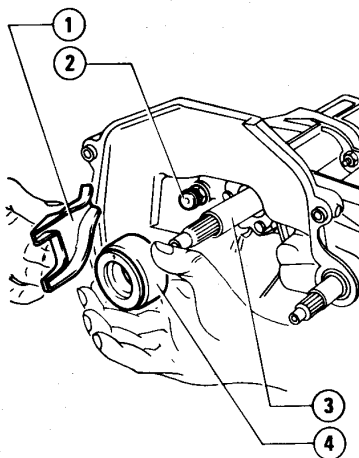

- 1 Control fork
- 2 Spherical pin
- 3 Guide sleeve
- 4 Thrust bearing

SINGLE-PLATE CLUTCH WITH "DRAWN" DIAPHRAGM SPRING AND DOUBLE-PLATE CLUTCH

DOUBLE-PLATE CLUTCH

1. Clutch unit disassembly.
 - a. Remove clutch operating cylinder from clutch-speed gear casing.
 - b. Remove fork (1) operating as per figure.

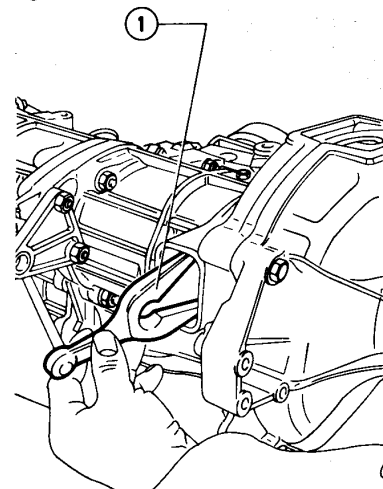

- 1 Clutch disengagement fork

CLUTCH

- c. Remove pin ② securing lever ① to speeds engagement and selection rod.
- d. Loosen and remove the four screws ③.

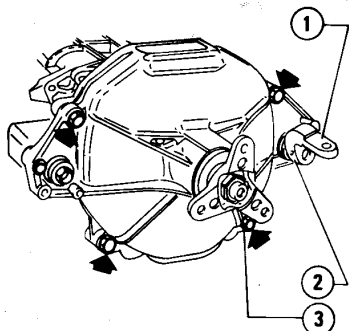

- 1 Lever
- 2 Pin
- 3 Screws securing clutch box to speed gear-clutch box

- e. Withdraw clutch unit from shaft.

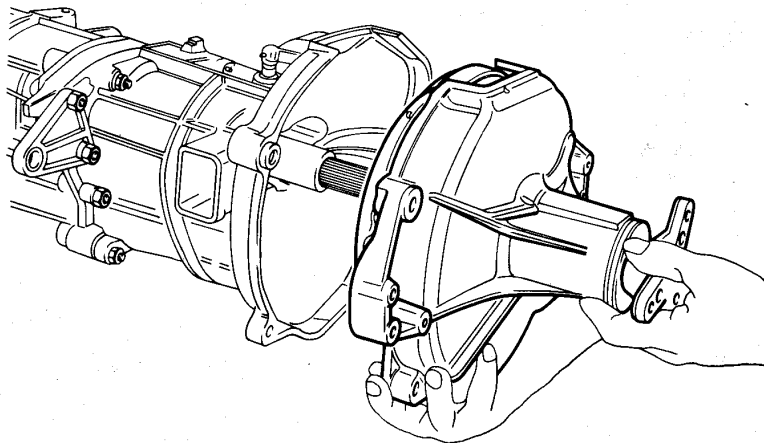

RECONNECTION

To reassemble clutch unit to speed gear-differential unit, reverse the order of disassembly and comply with the following:

- a. Lubricate spherical pin on clutch operating cylinder with the prescribed grease.

Clutch disengagement fork spherical pin

Grease:

AGIP Grease 33 FD
IP Autogrease FD

- b. Lubricate the thrust bearing guide sleeve and fork working surfaces with the prescribed grease.

Thrust bearing and clutch disengagement fork working seat

Grease:

AGIP Grease 33 FD
IP Autogrease FD

- c. Tighten crosswise the securing screws to the prescribed torque.

Ⓣ: Tightening torque

Screws securing clutch unit to speed gear-differential unit

29 to 32 N·m
(2.9 to 3.3 kg·m
21 to 23.9 ft·lb)

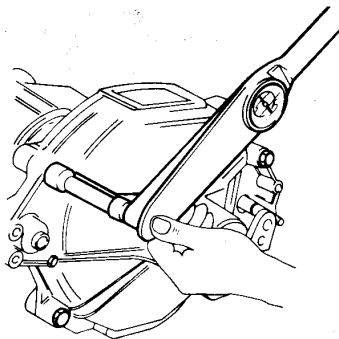

- d. If previously detached, reconnect hose end of hydraulic system to operating cylinder tightening union to the prescribed torque.

Ⓣ: Tightening torque

Union of clutch hydraulic system hose

10 to 15 N·m
(1 to 1.5 kg·m
7.2 to 10.8 ft·lb)

- e. Reinstall lever on speeds engagement and selection rod, and secure it with a new securing pin.

CLUTCH UNIT REMOVAL AND INSTALLATION (Intervention on vehicle)

REMOVAL

Single-plate clutch with "pushed" diaphragm spring

1. Remove front and central part of exhaust system, disconnect propeller shaft from clutch shaft fork, remove speeds engagement and selection rod and disconnect isostatic control from gear lever, operating as per: Group 13 - "Outer Linkage - Speed Gear Control Assembly - Removal".
2. Unscrew union (4) disconnecting hose (1) and pipe (5) of clutch system. Plug pipe so as to prevent leaks.
3. Unscrew nut (3) and disconnect hose (1) from bracket (2).

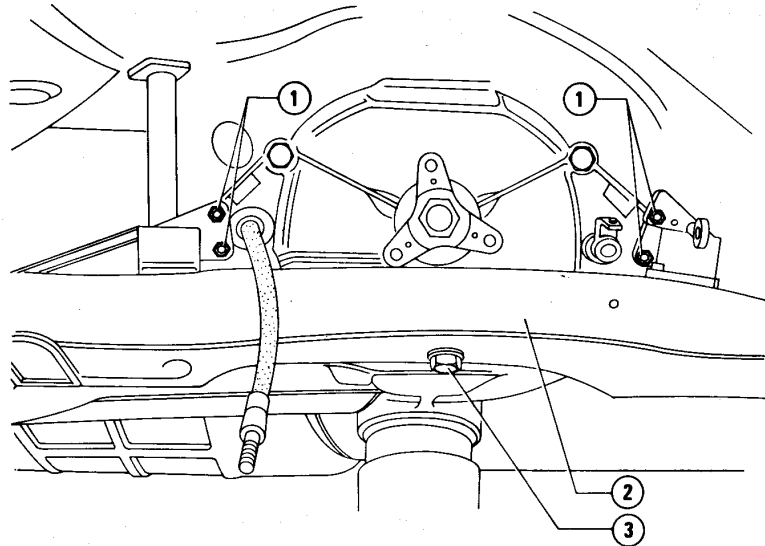

- 1 Bolts securing clutch-speed gear- differential unit to supports
- 2 Cross member
- 3 Nut securing cross member

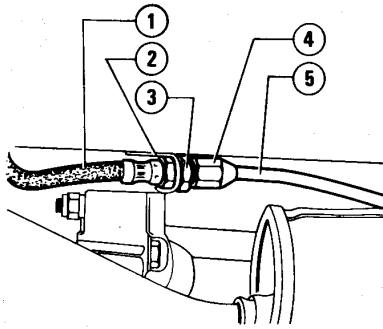

- 1 Hose
- 2 Support bracket
- 3 Nut securing hose to bracket
- 4 Pipe - hose union
- 5 Pipe

4. Unscrew and remove bolts (1) securing clutch-speed gear-differential unit to flexible supports on cross member (2). Unscrew nut (3) and remove cross member.

5. Withdraw pin (1) from lever (2), then remove lever.

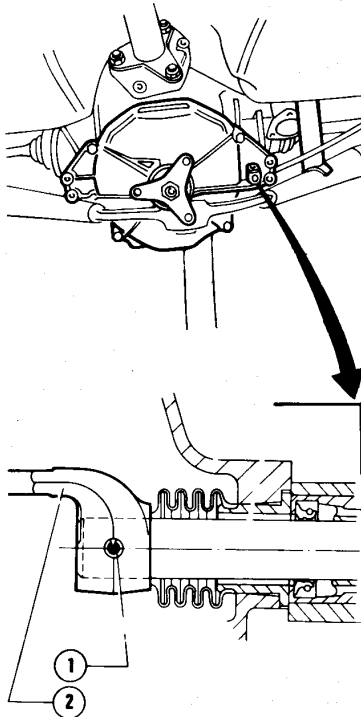

- 1 Spring pin
- 2 Speeds control rear lever

6. Remove boot from clutch operating cylinder
7. Unscrew screws (1) and remove unit from main shaft splined section.

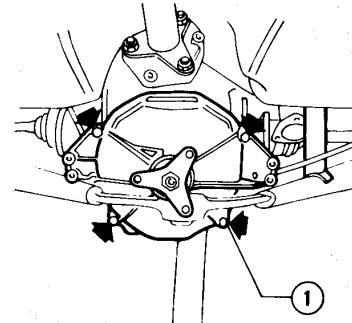

- 1 Screw securing clutch unit to speed gear-differential unit

8. Withdraw bearing (1), protection sleeve and fork (2) from sleeve on shaft.

CLUTCH

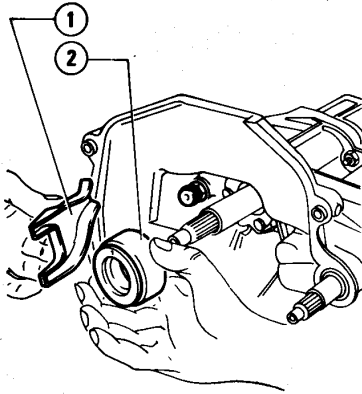

- 1 Thrust bearing
- 2 Clutch disengagement fork

Single-plate clutch with "drawn" diaphragm spring and double-plate clutch

Proceed per the single-plate clutch with "pushed" diaphragm spring, taking care to withdraw fork ① before removing the clutch unit.

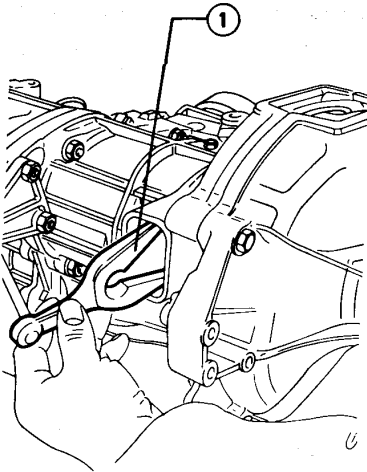

- 1 Clutch disengagement fork

INSTALLATION

For installation, reverse the order of removal and comply with following:

- Lubricate the following items with the prescribed grease: clutch fork spherical pin; thrust bearing seat and spherical seat of operating cylinder push rod.

Grease:

AGIP Grease 33 FD
or
IP Autogrease FD

- Lubricate the spherical seat of propeller shaft rear joint with the prescribed grease.

Grease:

ISECO Molykote BR2

- Comply with the following tightening torques

Ⓣ: Tightening torques

- Screws securing clutch unit to speed gear-differential unit

29 to 32 N·m
(2.9 to 3.9 kg·m
21 to 23.9 ft·lb)

- Screws securing propeller shaft joint to clutch shaft fork

Single-plate clutch with "pushed" diaphragm spring

40 to 50 N·m
(4 to 5 kg·m
28.9 to 36.1 ft·lb)

Single-plate clutch with "drawn" diaphragm spring and double-plate clutch

55 to 57 N·m
(5.6 to 5.8 kg·m
40.5 to 41.9 ft·lb)

- Unions of clutch hydraulic system pipes

8 to 10 N·m
(0.8 to 1 kg·m
5.8 to 7.2 ft·lb)

- Unions of clutch hydraulic system hoses

10 to 15 N·m
(1 to 1.5 kg·m
7.2 to 10.8 ft·lb)

- If necessary, carry out air bleeding from clutch hydraulic system (refer to: "Hydraulic System Bleeding").
- Install the lever on the speeds control rod making use of a new pin.

CLUTCH

CLUTCH UNIT OVERHAUL AT BENCH

Single-plate clutch with "pushed" diaphragm spring

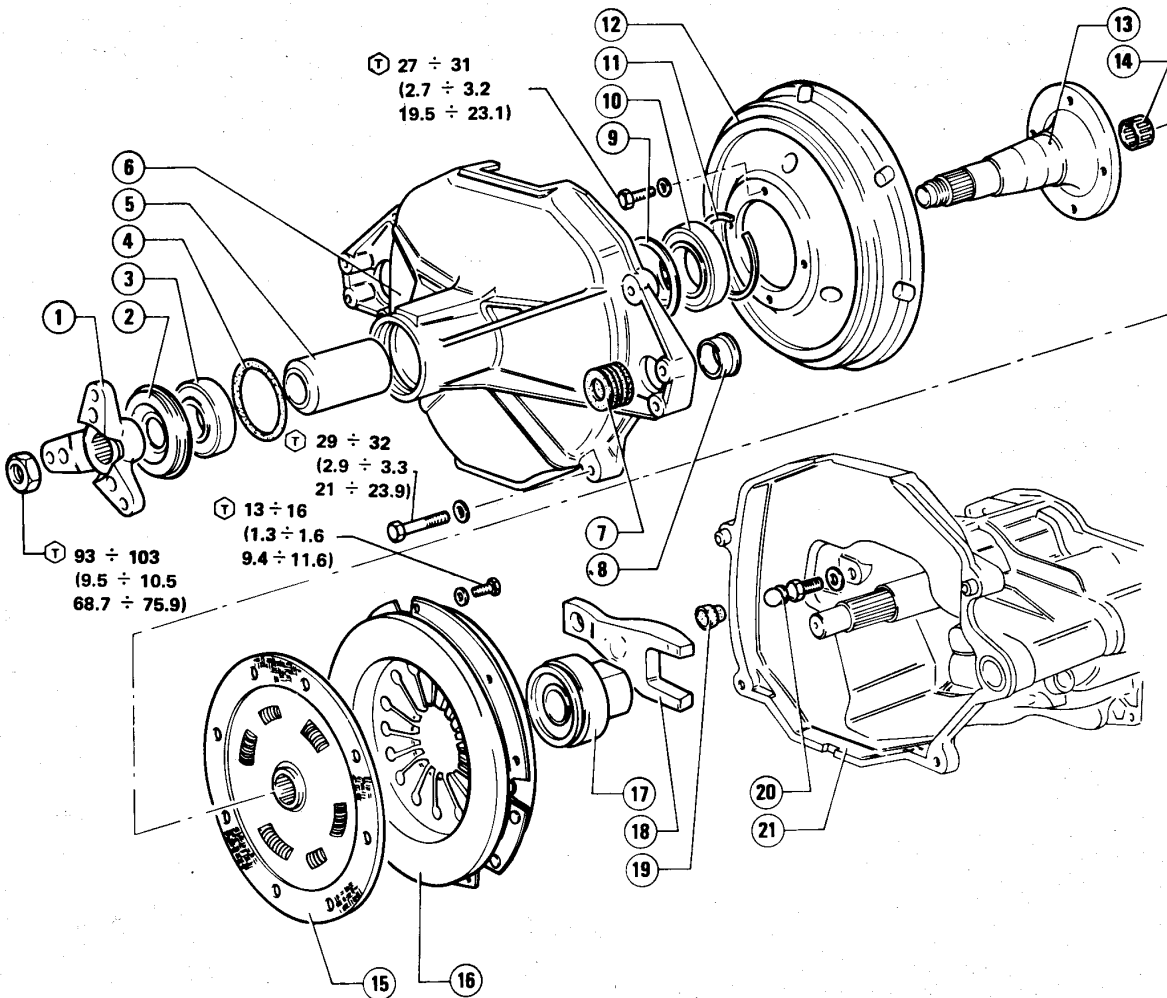

Ⓣ N-m
(kg-m
ft-lb)

- 1 Propeller shaft connection fork
- 2 Dust cover
- 3 Clutch cover front bearing
- 4 O-ring
- 5 Spacer
- 6 Clutch cover
- 7 Speeds engagement and selection rod boot

- 8 Speeds engagement and selection rod bush
- 9 Shoulder washer
- 10 Clutch cover rear bearing
- 11 Rear bearing retaining ring
- 12 Clutch flywheel
- 13 Clutch shaft
- 14 Needle bearing

- 15 Clutch plate
- 16 Pressure plate body
- 17 Thrust bearing
- 18 Fork
- 19 Rubber cap on spherical pin
- 20 Spherical pin
- 21 Clutch-speed gear casing

CLUTCH

Single-plate clutch with "drawn" diaphragm spring

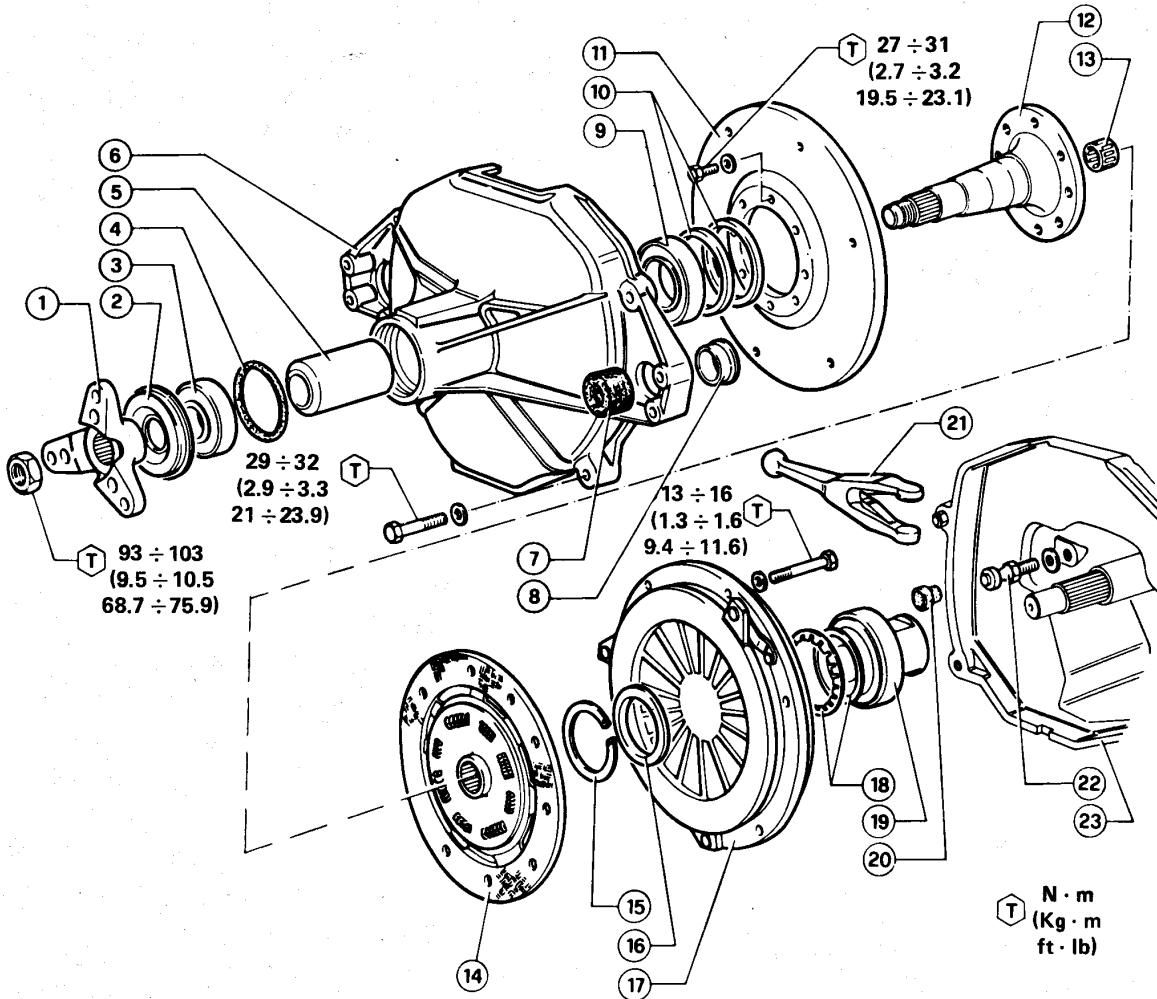

T N · m
(Kg · m
ft · lb)

- 1 Propeller shaft connection fork
- 2 Dust cover
- 3 Clutch cover front bearing
- 4 O-Ring
- 5 Spacer
- 6 Clutch cover
- 7 Speeds engagement and selection rod boot
- 8 Speeds engagement and selection rod bush
- 9 Clutch cover rear bearing
- 10 Threaded ring nuts for rear bearing securing
- 11 Clutch flywheel
- 12 Clutch shaft

- 13 Needle bearing
- 14 Clutch plate
- 15 Retaining ring
- 16 Ring
- 17 Pressure plate body
- 18 Belleville springs
- 19 Thrust bearing
- 20 Rubber cap on spherical pin
- 21 Fork
- 22 Spherical pin
- 23 Clutch-speed gear casing

CLUTCH

Double-plate clutch

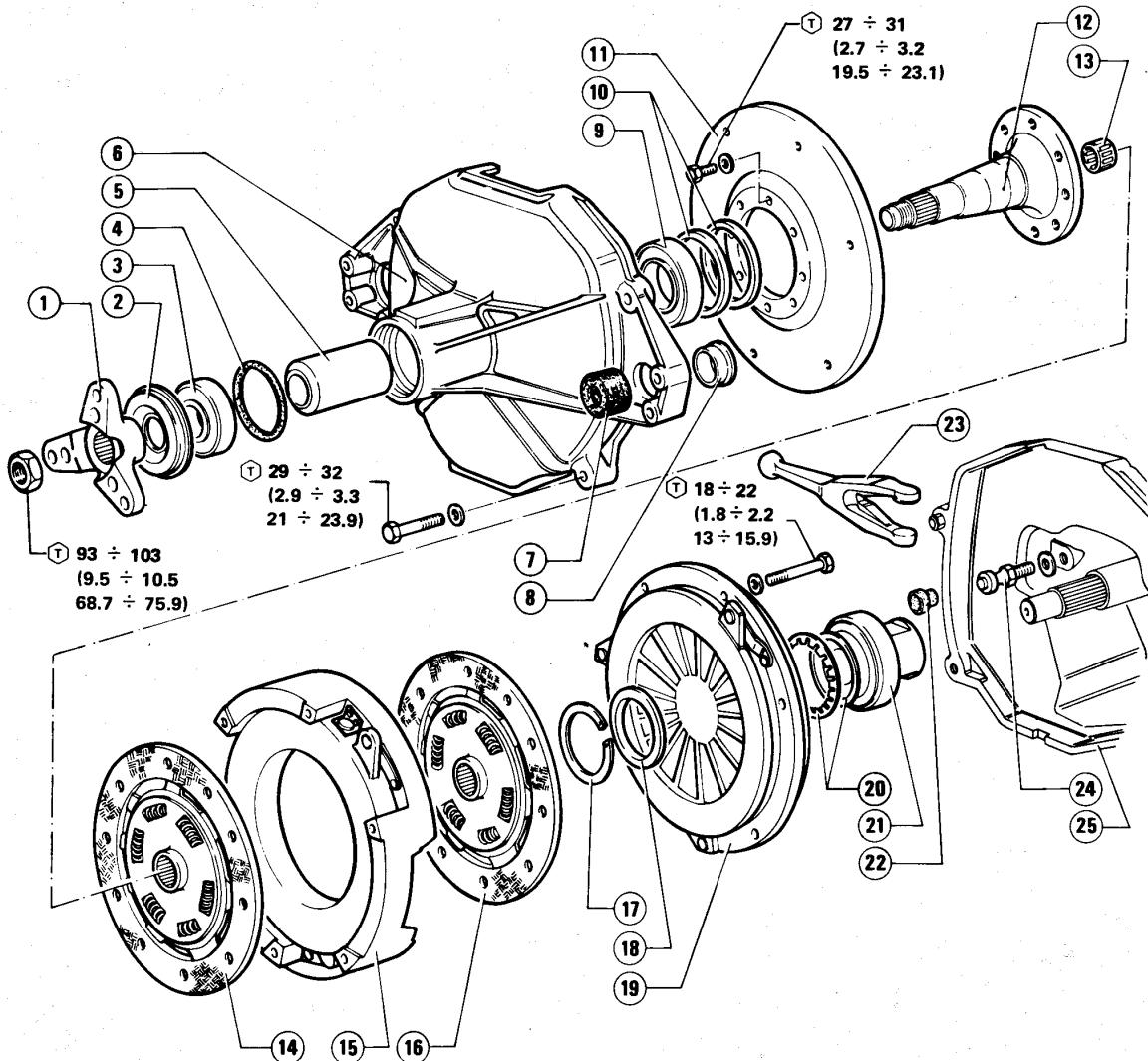

T N-m
(kg-m
ft-lb)

- | | |
|---|-------------------------------------|
| 1 Propeller shaft connection fork | 14 Front clutch plate |
| 2 Dust cover | 15 Intermediate pressure plate body |
| 3 Clutch cover front bearing | 16 Rear clutch plate |
| 4 O-Ring | 17 Retaining ring |
| 5 Spacer | 18 Ring |
| 6 Clutch cover | 19 Rear pressure plate body |
| 7 Speeds engagement and selection rod boot | 20 Belleville springs |
| 8 Speeds engagement and selection rod bush | 21 Thrust bearing |
| 9 Clutch cover rear bearing | 22 Rubber cap on spherical pin |
| 10 Threaded ring nuts for rear bearing securing | 23 Fork |
| 11 Clutch flywheel | 24 Spherical pin |
| 12 Clutch shaft | 25 Clutch-speed gear casing |
| 13 Needle bearing | |

CLUTCH

SINGLE-PLATE CLUTCH WITH "PUSHED" DIAPHRAGM SPRING

DISASSEMBLY

1. Clutch cover removal

- a. Unscrew and remove bolt ①, then remove operating cylinder ②.

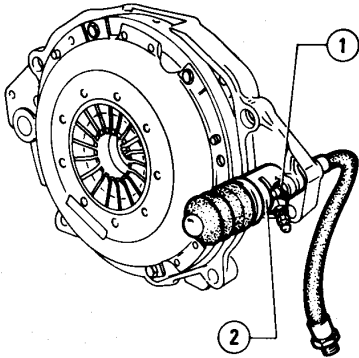

- 1 Bolt securing operating cylinder to clutch cover
2 Clutch operating cylinder

- b. If necessary, remove boot ② and bush ① from clutch cover.

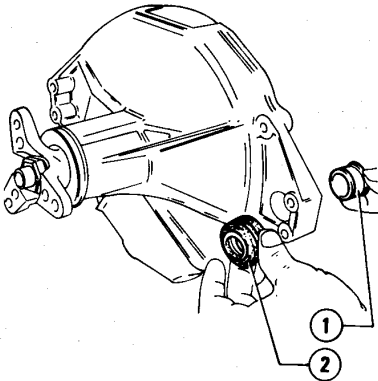

- 1 Speeds engagement and selection rod bush
2 Speed engagement and selection rods boot

- c. Secure clutch cover on vice fitted with jaws, as per figure. Release and remove the nut securing propeller shaft fork.

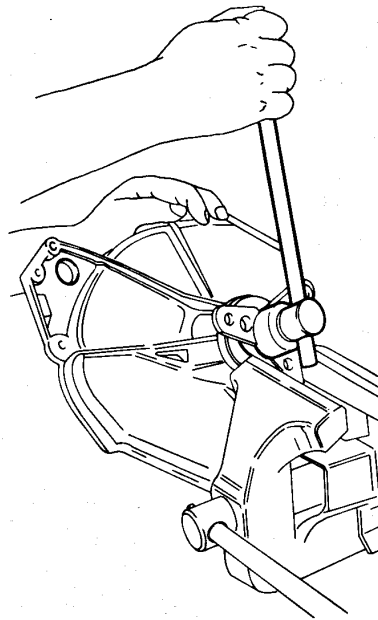

- d. By means of extractor A.3.0477, withdraw fork ①, then remove dust cover ②.

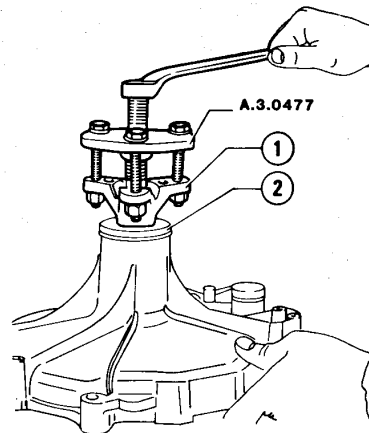

- 1 Propeller shaft connecting fork
2 Dust cover

- e. Withdraw cover of clutch flywheel shaft.

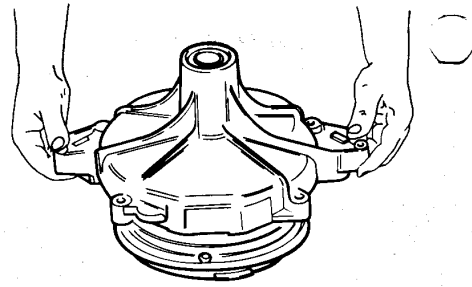

2. Clutch unit disassembly

- a. If not present, carry out the countermarking between flywheel and pressure plate body so that correct order can be maintained when reassembling. Loosen and release the screws with related washers securing pressure plate body ① to flywheel ②.

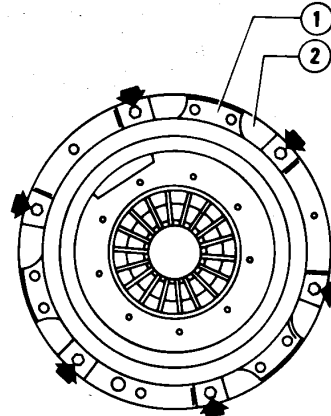

- 1 Pressure plate body
2 Clutch flywheel

- b. Separate pressure plate body ② and clutch plate ① from flywheel.

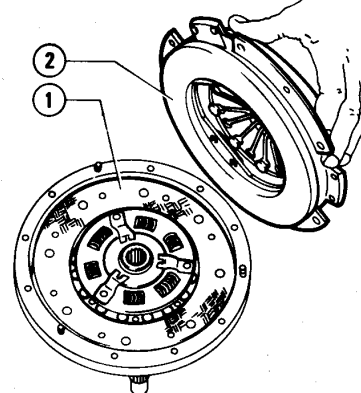

- 1 Clutch plate
2 Pressure plate body

CLUTCH

c. If necessary, withdraw centering bearing ③ of speed gear main shaft from shaft ②, by means of suitable extractor.

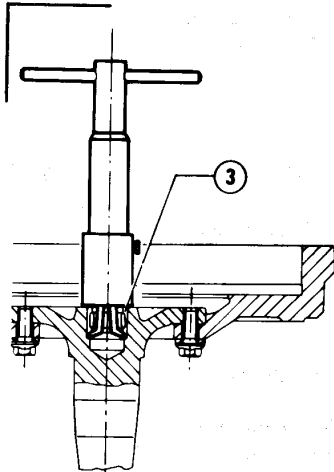
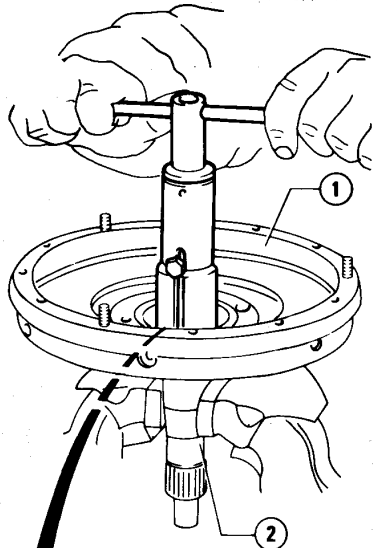

- 1 Clutch flywheel
- 2 Clutch shaft
- 3 Needle bearing

d. If necessary, unscrew and remove the screws with related washers securing flywheel ① to shaft ②.

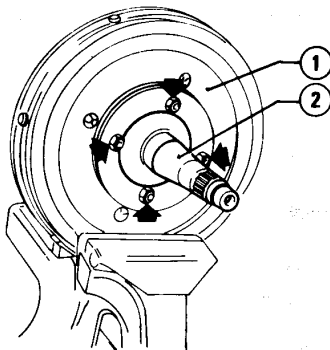

- 1 Clutch flywheel
- 2 Clutch shaft

3. Removal of clutch cover bearings

a. Remove retaining ring ① of rear bearing ②.

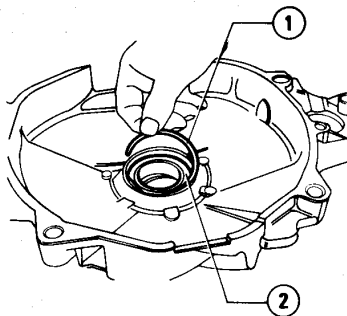

- 1 Rear bearing retaining ring
- 2 Clutch cover rear bearing

b. Set clutch cover on a suitable base and, disaligning spacer, tap uniformly, by means of a punch, on outer race of front bearing ② in order to remove it from the related cover; recover spacer ①.

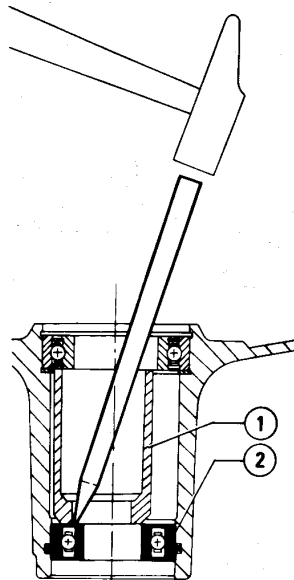
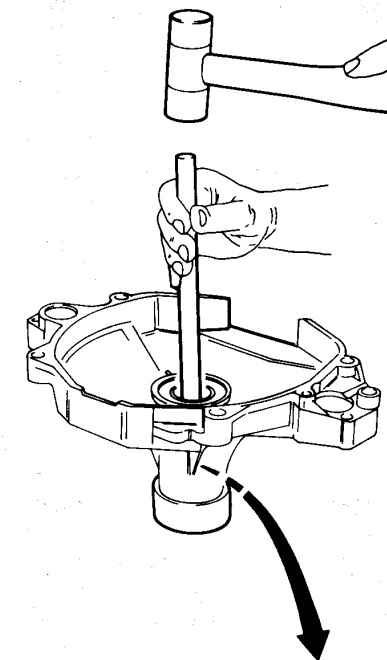

- 1 Bearings spacer
- 2 Clutch cover front bearing

c. Withdraw ring ① from cover.

CLUTCH

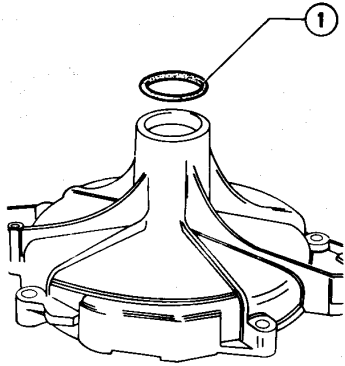

1 O-Ring

d. By means of a suitable extractor, withdraw rear bearing ① together with shoulder washer ②.

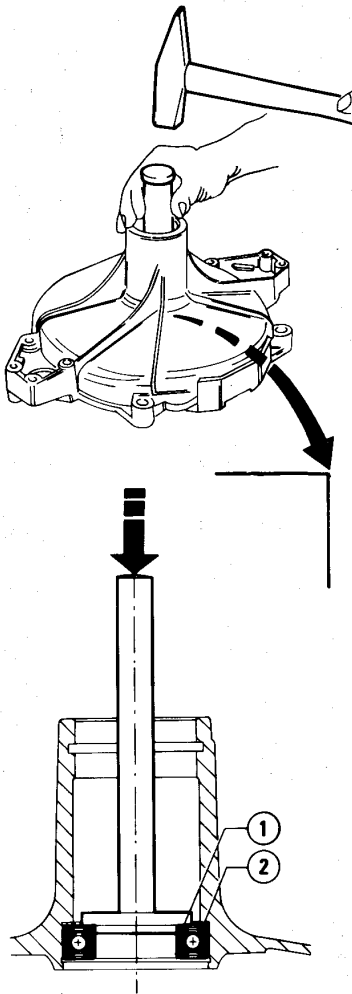

1 Clutch cover rear bearing
2 Shoulder washer

CHECKS AND INSPECTIONS

Before carrying out the checks and inspections, wash with suitable solvent all the disassembled items (exception made for the driven plate), to eliminate the residual dust and grease. Use denatured ethyl alcohol to eliminate sealant residuals.

1. Clutch plate

Verify wear degree of clutch plate and check that:

- Plate gaskets are free from burns, greasy residuals and vetrification.
- Wear is uniform.
- Gaskets securing rivets are perfectly riveted.
- Clutch plate springs are in good conditions.
- In the event of clutch malfunctions, due to oil leaks from seal ring on the direct drive shaft, both clutch plate and seal ring are replaced.
- Hub of plate ③ is in good conditions and slides without sticking or excessive backlash on direct drive shaft coupling ②. If necessary, replace the whole plate.

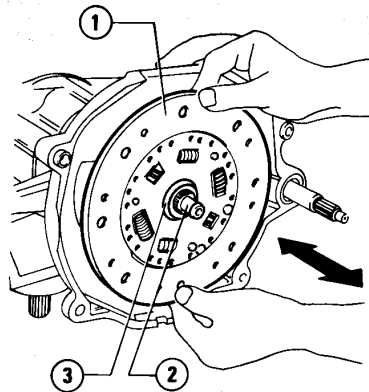

1 Clutch plate
2 Direct drive shaft
3 Clutch plate hub

2. Pressure plate

Verify that pressure plate working surface ② is free from overheating, uneven wear, scores and removal of material.

If necessary, replace the pressure plate.

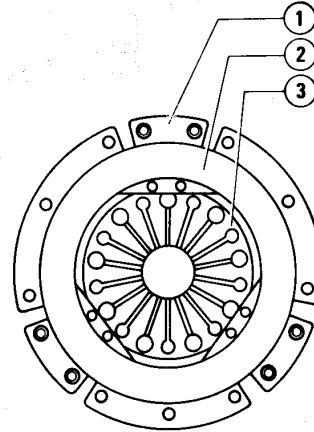

1 Pressure plate
2 Pressure plate working surface
3 Diaphragm spring

3. Clutch disengagement fork and thrust bearing

- a. Verify that thrust bearing is not noisy, free from excessive backlash and that it slides freely on guide sleeve.
- b. Verify that clutch disengagement fork is free from cracks, deformations and excessive wear of working surfaces. Replace it, if necessary.

CLUTCH

4. Clutch cover

Check for good conditions of clutch cover; examine accurately the ball bearings supporting clutch flywheel shaft; replace them if too worn or in the event of seizing or noise.

5. Flywheel

Check for overheating, uneven wear, scoring or removal of material on flywheel working surface (2). If necessary, disassemble flywheel and grind both working surface and pressure plate support plane (1).

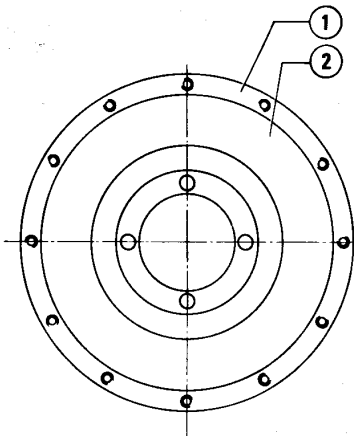

- 1 Pressure plate support plane
- 2 Working surface

The following must be taken into account when grinding flywheel:

- a. Removal of material on driven plate support plane must be such that the dimension between driven plate support plane and pressure plate is within the

below values.

- For clutch plates \varnothing 200 mm dia. (7.87 in)
A = 25 + 0.2 mm (0.9842 + 0.0078 in)
- For clutch plates \varnothing 215 mm dia. (8.46 in)
A = 22.5 + 0.2 mm (0.8858 + 0.0078 in)

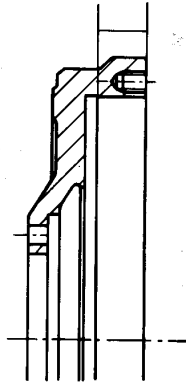

- b. Should dimension A be out of tolerance, remove material also from support plane of pressure plate.
- c. As regards the tolerances, refer to: "Service Data and Specifications".

CAUTION:

- a. Should replacement operations or interventions be required on flywheel, pressure plate and flywheel-clutch shaft, the whole unit should be replaced so as not to alter balancing.
- b. Or, after grinding or replacement of a few components, carry out balancing of the whole unit.

6. Needle bearing

Verify that centering needle bearing of main shaft, previously removed from clutch shaft, is free from seizures, excessive wear; replace it if necessary.

7. Clutch flywheel shaft

Examine thoroughly the clutch flywheel shaft. Replace it if working surfaces are worn.

REASSEMBLY

1. Clutch cover bearing insertion

Operate as follows to reassemble clutch cover.

- a. Insert shoulder washer (2) on cover and, by means of tool A.3.0282, fit bearing (1) completely. Install retaining ring making sure it is housed in the related seat.

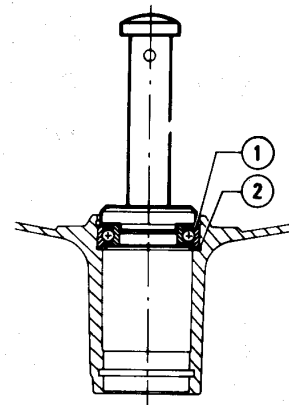
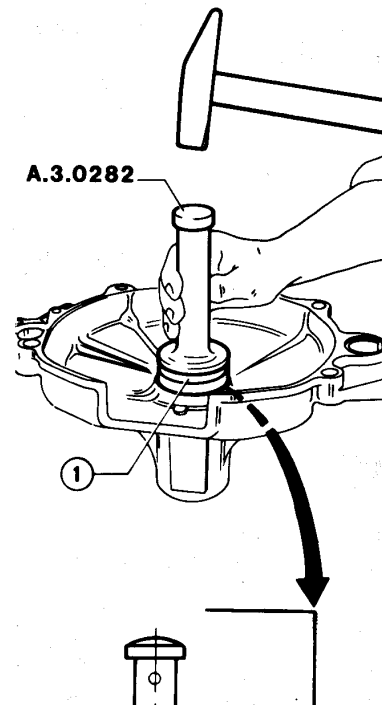

- 1 Cover rear bearing
- 2 Shoulder washer

CLUTCH

- b. Overturn cover and install spacer (2) taking care to position it with the chamfered side towards front part of cover, then install O-ring (1).

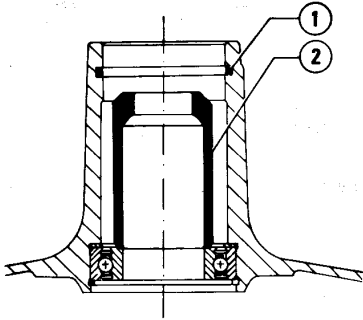

- 1 O-ring
2 Spacer

- c. Insert front ball bearing.
d. Refit retaining ring (1) of clutch cover bearing (2).

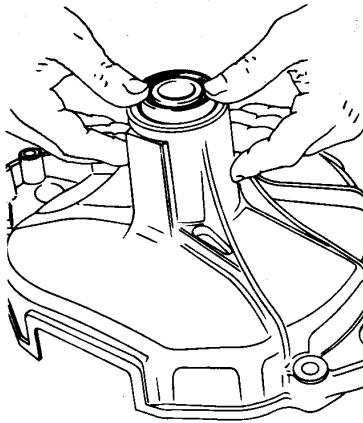

- 1 Ring
2 Rear bearing

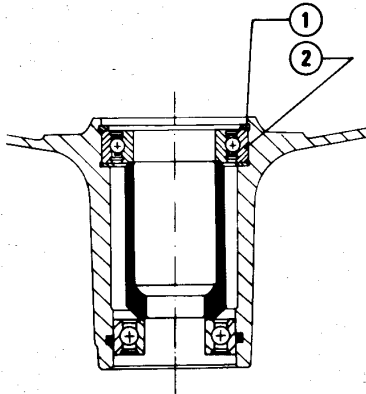

2. Clutch unit reassembly

- a. If previously disassembled, reassemble flywheel unit (1) and shaft (2). To carry out this operation, tighten the new securing screws treated with **LOCTITE sealing compound Stud Lok (red)** to the prescribed torque, operating as per figure, with flywheel arranged on vice fitted with protective jaws.

- (T): Tightening torque
Screws securing clutch shaft to flywheel

27 to 31 N·m
(2.7 to 3.2 kg·m
19.5 to 23.1 ft·lb)

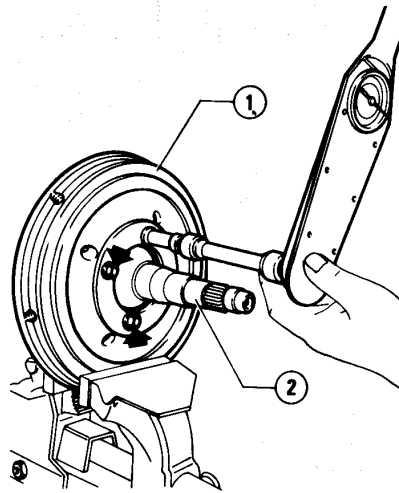

- 1 Clutch flywheel
2 Clutch shaft

- b. If previously disassembled, insert bearing (1), housed in the clutch flywheel shaft, by means of tool A.3.0405.

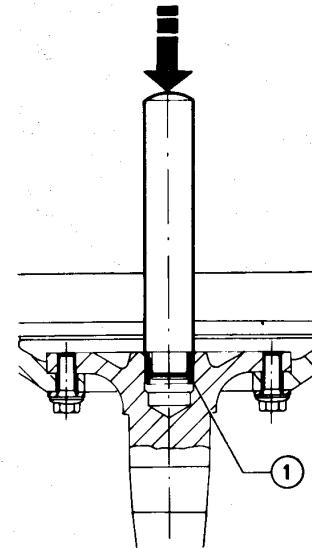
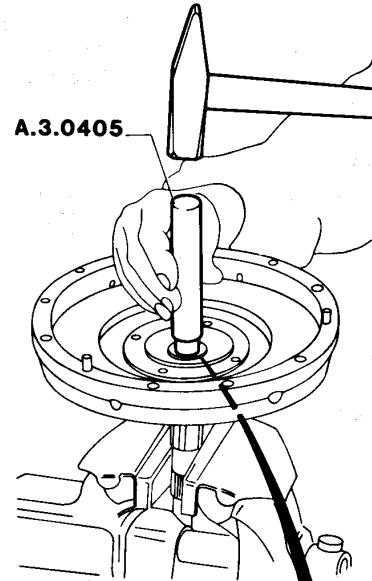

- 1 Needle bearing

- c. Insert driven plate (1) into flywheel (2) with the hub jutting part towards outside, as shown in the figure.

CLUTCH

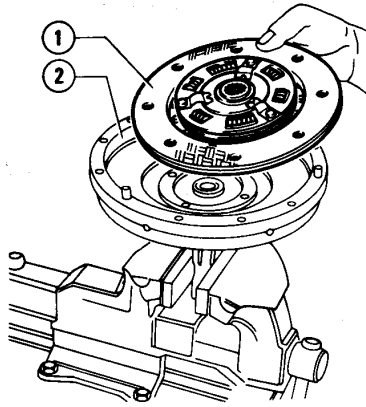

- 1 Driven plate
- 2 Clutch flywheel

d. Install pressure plate body on flywheel. By means of spindle A.4.0205, center the clutch plate and tighten, cross-wise, the screws securing pressure plate body ① to flywheel.

T : Tightening torque

Screws securing pressure plate body to flywheel

13 to 16 N·m
(1.3 to 1.6 kg·m
9.4 to 11.6 ft·lb)

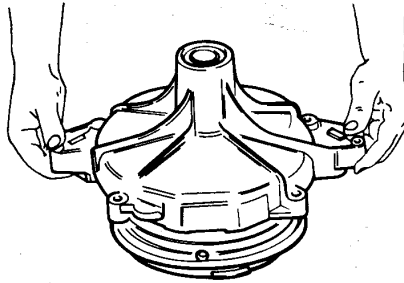

b. Insert dust cover ②

c. Apply a layer of **Sealing compound LOCTITE 242 (Blue)** on shaft tang, taking care to remove previous sealant residuals by swabbing and blowing the surfaces concerned. However, remove grease from surfaces by means of denatured ethyl alcohol.

d. Insert fork ① on clutch shaft and secure it with the related nut lock fork on a vice fitted with protective jaws, as per figure, and tighten nut to the prescribed torque.

T : Tightening torque

Nut securing propeller shaft connecting fork to clutch shaft

93 to 103 N·m
(9.5 to 10.5 kg·m
68.7 to 75.9 ft·lb)

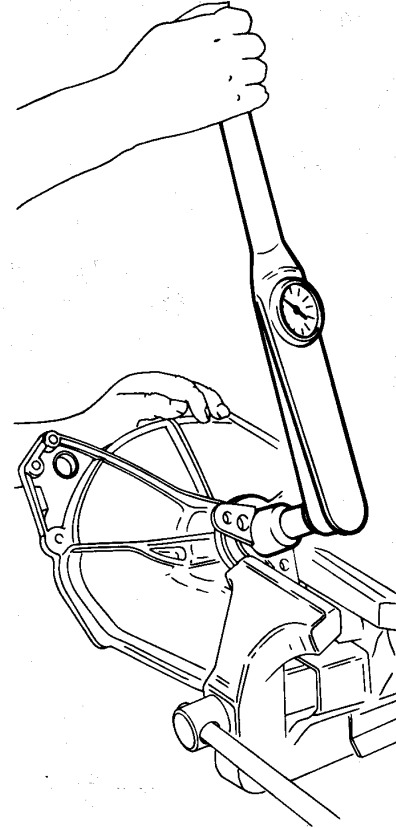

e. Reinstall bush ① and boot ②.

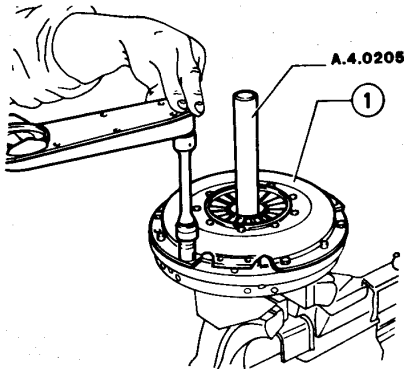

- 1 Pressure plate body

3. Clutch cover reassembly

a. Remove spindle A.4.0205 and reinstall cover on clutch unit.

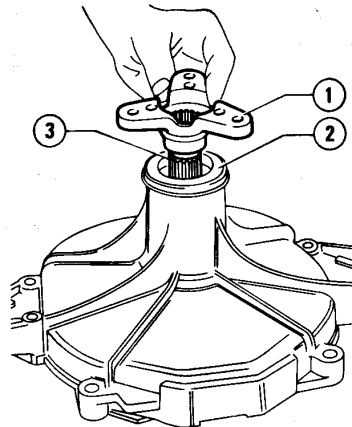

- 1 Fork
- 2 Dust cover
- 3 Splined tang

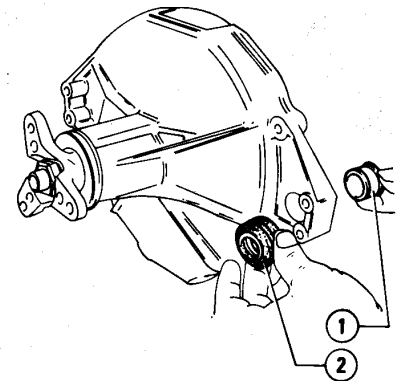

- 1 Bush for speeds engagement and selection rod
- 2 Boot

f. Reconnect operating cylinder ② to clutch cover and tighten bolt ①.

CLUTCH

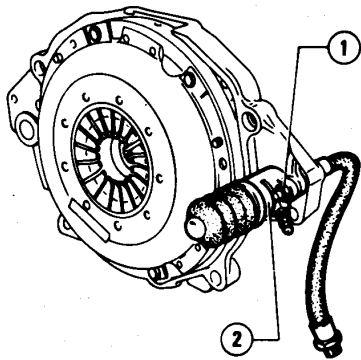

- 1 Clutch cover securing bolt
- 2 Fork operating cylinder

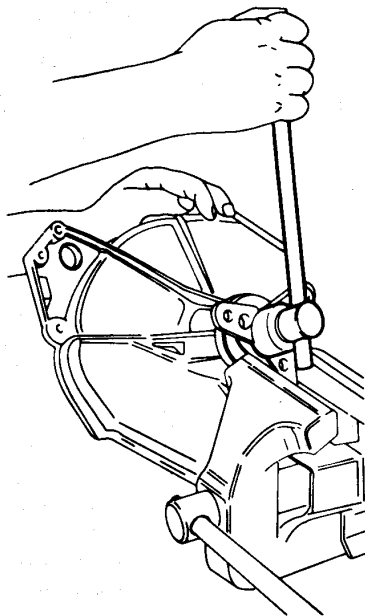

SINGLE-PLATE CLUTCH WITH "DRAWN" DIAPHRAGM SPRING

DISASSEMBLY

1. Clutch cover removal

- a. If necessary, remove boot (2) and bush (1) from clutch cover.

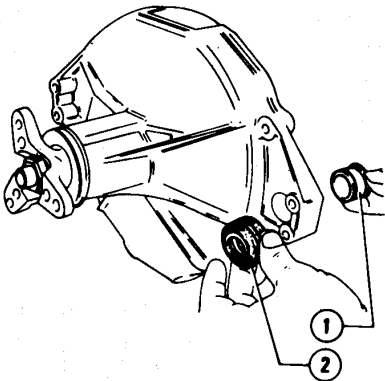

- 1 Speeds engagement and selection rod bush
- 2 Speed engagement and selection rods boot

- b. Secure clutch cover on vice fitted with jaws, as per figure. Release and remove the nut securing propeller shaft fork.

- c. By means of extractor A.3.0600 withdraw fork (1), then remove dust cover (2).

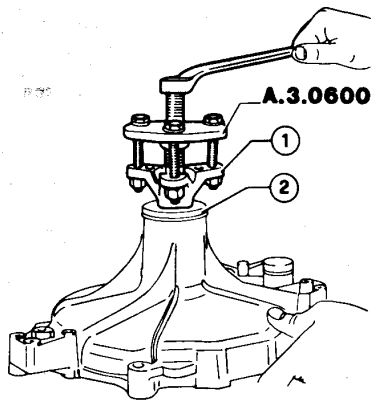

- 1 Propeller shaft connecting fork
- 2 Dust cover

- d. Withdraw cover of clutch flywheel shaft.

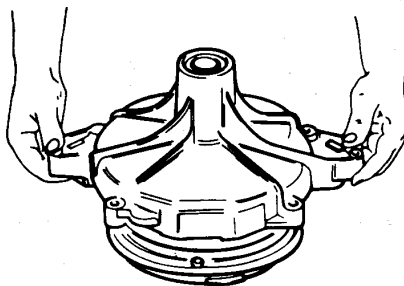

2. Clutch unit disassembly

- a. If not present, carry out the counter-marking between flywheel and pressure plate body so that correct order can be maintained when reassembling. Loosen and release the screws with related washers securing pressure plate body (1) to flywheel (2).

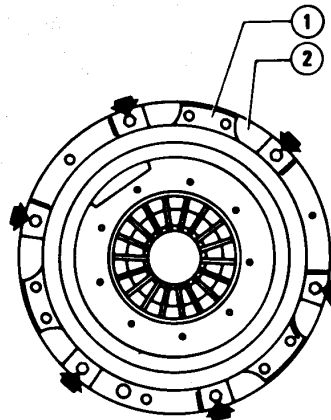

- 1 Pressure plate body
- 2 Clutch flywheel

- b. Separate pressure plate body (2) and clutch plate (1) from flywheel.

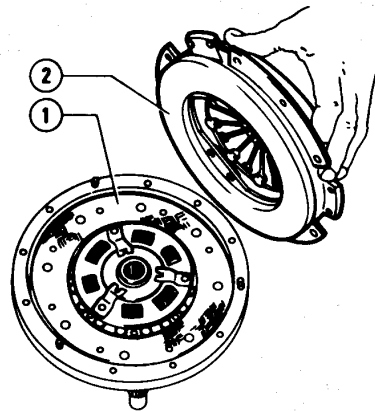

- 1 Clutch plate
- 2 Pressure plate body

- c. If necessary, withdraw centering bearing (3) of speed gear main shaft from shaft (2), by means of suitable extractor.

CLUTCH

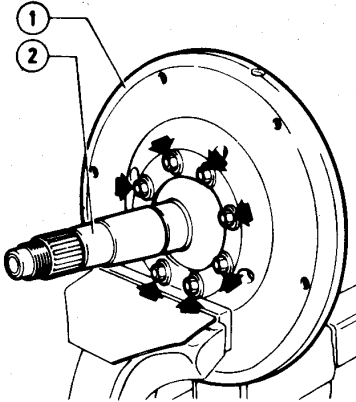
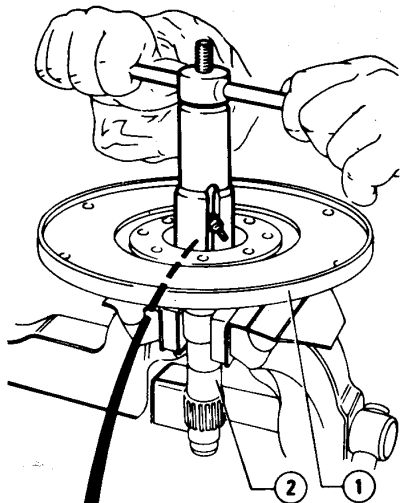

- 1 Clutch flywheel
- 2 Clutch shaft

3. Thrust bearing removal

- a. Set rear pressure plate body as per figure, then slightly press on it to overcome the reaction of bearing Belleville spring and remove retaining ring ①.
- b. Remove ring ② securing thrust bearing to diaphragm spring ③.

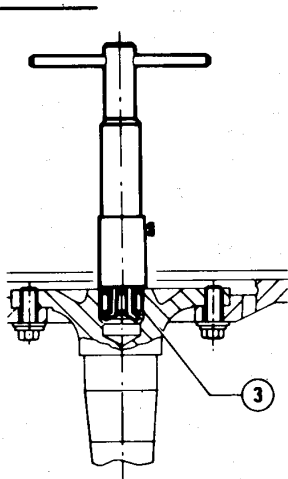

- 1 Clutch flywheel
- 2 Clutch shaft
- 3 Needle bearing

- d. If necessary, unscrew and remove the screws with related washers which secure flywheel ① to shaft ②; separate shaft from flywheel.

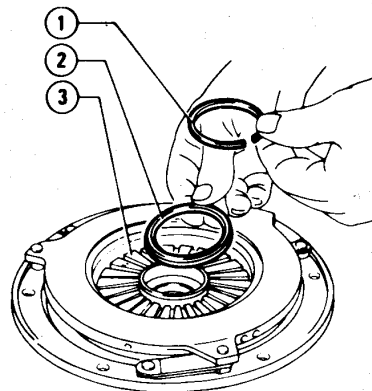
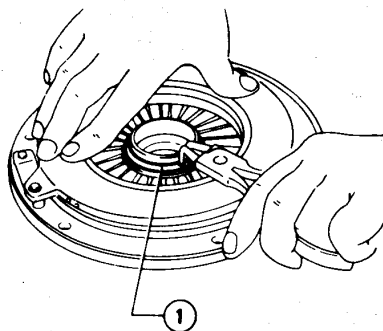

- 1 Retaining ring
- 2 Ring
- 3 Diaphragm spring

- c. Remove bearing ② from rear pressure plate body and recover spring ①.

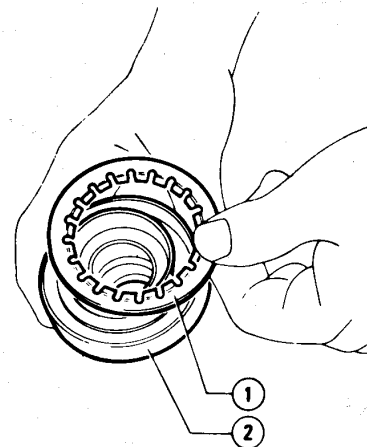

- 1 Belleville spring
- 2 Thrust bearing

4. Removal of clutch cover bearings

- a. Unscrew the two ring nuts ① securing bearing ②.

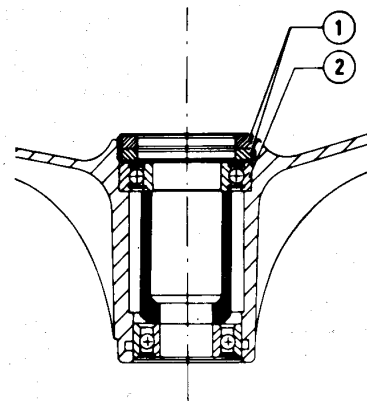

- 1 Threaded ring nuts
- 2 Rear bearing

CLUTCH

b. Set clutch cover on a suitable base and, disaligning spacer, tap uniformly, by means of a punch, on outer race of front bearing ② in order to remove it from the related cover; recover spacer ①.

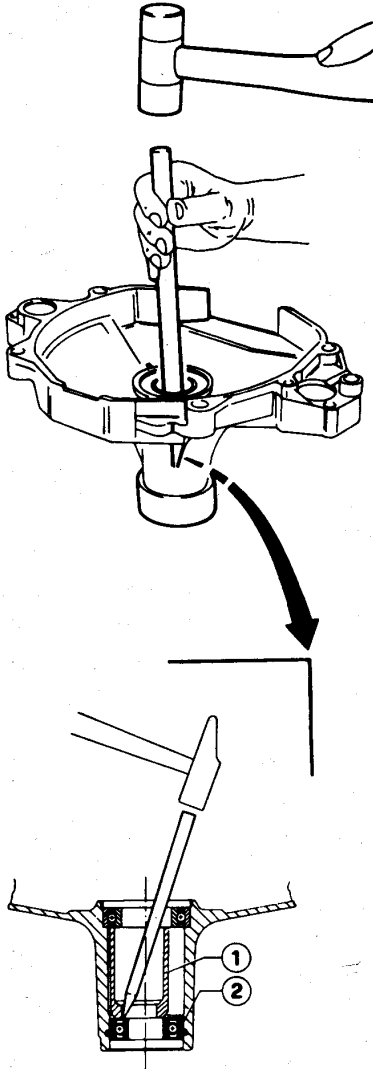

- 1 Bearings spacer
- 2 Clutch cover front bearing

c. Withdraw ring ① from cover.

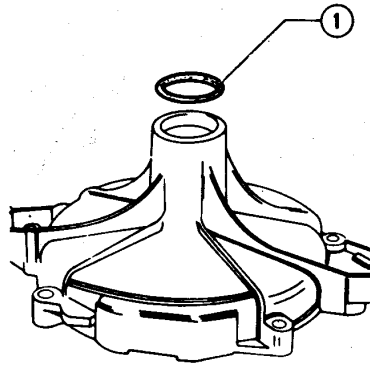

- 1 O-Ring

d. By means of a suitable extractor, withdraw rear bearing ①.

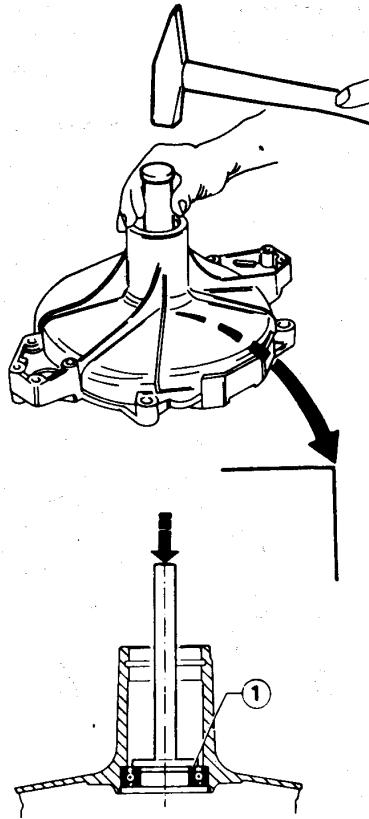

- 1 Clutch cover rear bearing

CHECKS AND INSPECTIONS

Before carrying out the checks and inspections, wash with suitable solvent all the disassembled items (exception made for the driven plate), to eliminate the residual dust and grease.

Use denatured ethyl alcohol to eliminate sealant residuals.

1. Clutch plate

Verify wear degree of clutch plate and check that:

- Plate gaskets are free from burns, greasy residuals and vetrification.
- Wear is uniform.
- Gaskets securing rivets are perfectly riveted.
- Clutch plate springs are in good conditions.
- In the event of clutch malfunctions, due to oil leaks from seal ring on the direct drive shaft, both clutch plate and seal ring are replaced.
- Hub of plate ③ is in good conditions and slides without sticking or excessive backlash on direct drive shaft coupling ②. If necessary, replace the whole plate.

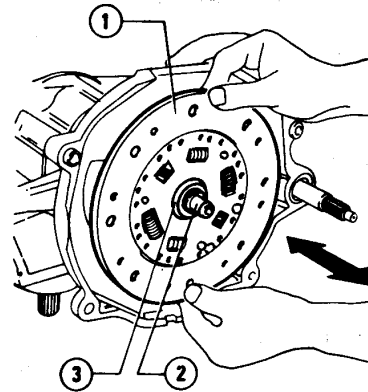

- 1 Clutch plate
- 2 Direct drive shaft
- 3 Clutch plate hub

CLUTCH

2. Pressure plate

Verify that pressure plate working surface (2) is free from overheating, uneven wear, scores and removal of material. If necessary, replace the pressure plate.

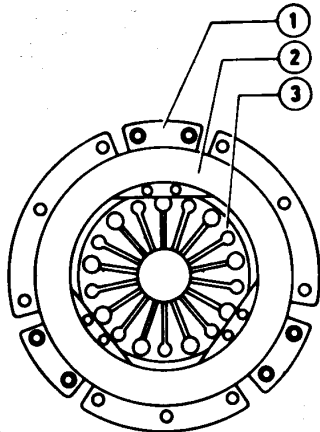

- 1 Pressure plate
- 2 Pressure plate working surface
- 3 Diaphragm spring

3. Clutch disengagement fork and thrust bearing

- a. Verify that thrust bearing is not noisy, free from excessive backlash and that it slides freely on guide sleeve.
- b. Verify that clutch disengagement fork is free from cracks, deformations and excessive wear of working surfaces. Replace it, if necessary.

4. Clutch cover

Check for good conditions of clutch cover; examine accurately the ball bearings supporting clutch flywheel shaft; replace them if too worn or in the event of seizing or noise.

5. Flywheel

Check for overheating, uneven wear, scoring or removal of material on flywheel working surface (2). If necessary, dis-

assemble flywheel and grind both working surface and pressure plate support plane (1).

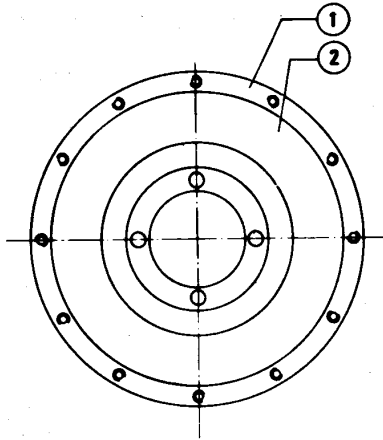

- 1 Pressure plate support plane
- 2 Working surface

For grinding tolerances, refer to "Service Data and Specifications".

CAUTION:

- a. Should replacement operations or interventions be required on flywheel, pressure plate and flywheel-clutch shaft, the whole unit should be replaced so as not to alter balancing.
- b. Or, after grinding or replacement of a few components, carry out balancing of the whole unit.

6. Needle bearing

Verify that centering needle bearing of main shaft, previously removed from clutch shaft, is free from seizures, excessive wear; replace it if necessary.

7. Clutch flywheel shaft

Examine thoroughly the clutch flywheel shaft. Replace it if working surfaces are worn.

REASSEMBLY

1. Clutch cover bearing insertion

Operate as follows to reassemble clutch cover.

- a. By means of tool A.3.0282 fit bearing (1) fully home and fix it by the two-threaded ring nuts.

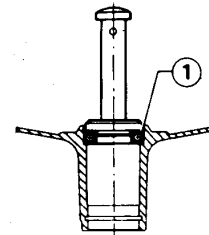
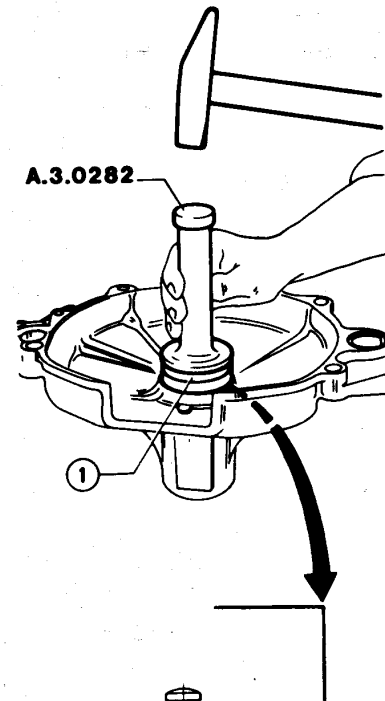

- 1 Cover rear bearing

CLUTCH

b. Overturn cover and install spacer ② taking care to position it with the chamfered side towards front part of cover, then install O-ring ①.

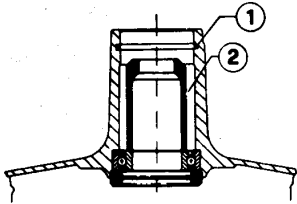

- 1 O-Ring
- 2 Spacer

c. Insert front ball bearing.

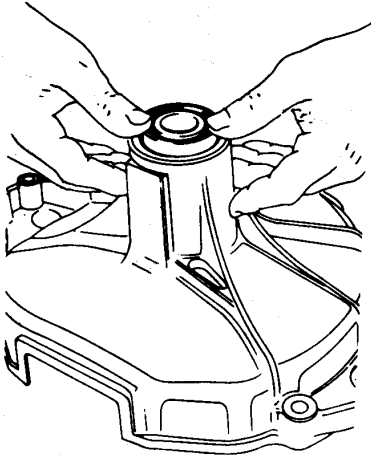

2. Thrust bearing reassembly

To reassemble thrust bearing, reverse the order of disassembly.

3. Clutch unit reassembly

a. If previously disassembled, reassemble flywheel unit ① and shaft ②. To carry out this operation, tighten the new securing screws treated with **LOCTITE sealing compound Stud Lok (red)** to the prescribed torque, operating as per figure, with flywheel arranged on vice fitted with protective jaws.

ⓧ : Tightening torque
Screws securing clutch shaft to flywheel

27 to 31 N·m
(2.7 to 3.2 kg·m)
(19.5 to 23.1 ft·lb)

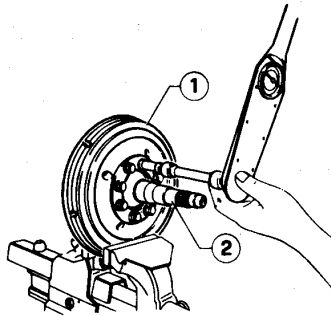

- 1 Clutch flywheel
- 2 Clutch shaft

b. If previously disassembled, insert bearing ①, housed in the clutch flywheel shaft, by means of tool A.3.0405.

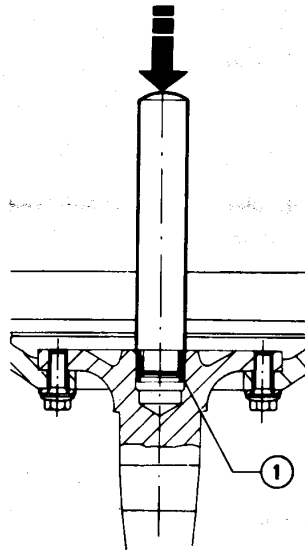
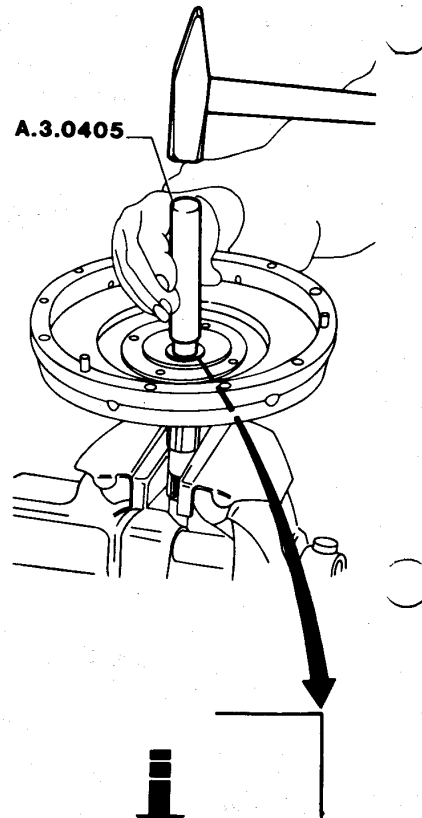

- 1 Needle bearing

CLUTCH

c. Insert driven plate ① into flywheel ② with the hub jutting part towards outside, as shown in the figure.

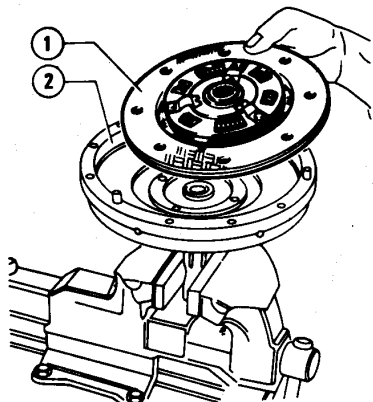

- 1 Driven plate
- 2 Clutch flywheel

d. Install pressure plate body on flywheel. By means of spindle A.4.0205, center the clutch plate and tighten, crosswise, the screws ① securing pressure plate body to flywheel.

T: Tightening torque
Screws securing pressure plate body to flywheel
13 to 16 N·m
(1.3 to 1.6 kg·m)
(9.4 to 11.6 ft·lb)

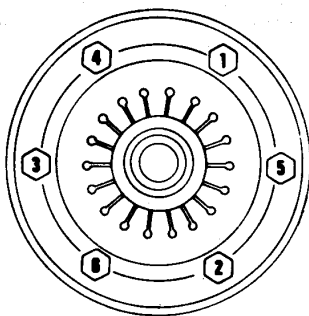
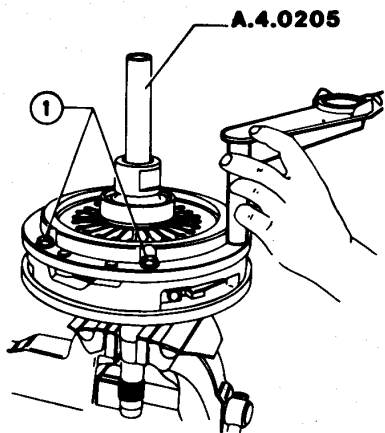

- 1 Screws securing pressure plate body to flywheel

4. Clutch cover reassembly

a. Remove spindle A.4.0205 and reinstall cover on clutch unit.

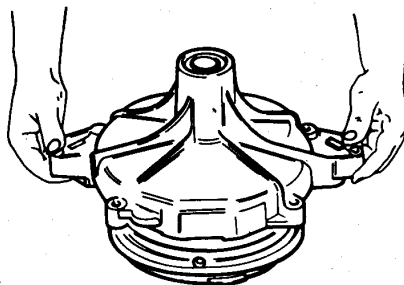

b. Insert dust cover ②.
c. Apply a layer of Sealing compound LOCTITE 242 (Blue) on shaft tang, taking care to remove previous sealant residuals by swabbing and blowing the surfaces concerned. However, remove grease from surfaces by means of denatured ethyl alcohol.
d. Insert fork ① on clutch shaft and secure it with the related nut lock fork on a vice fitted with protective jaws, as per figure, and tighten nut to the prescribed torque.

T: Tightening torque
Nut securing propeller shaft connecting fork to clutch shaft
93 to 103 N·m
(9.5 to 10.5 kg·m)
(68.7 to 75.9 ft·lb)

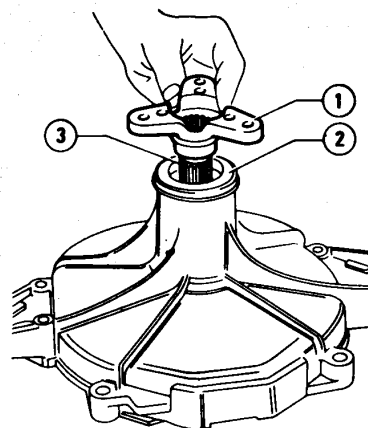

- 1 Fork
- 2 Dust cover
- 3 Splined tang

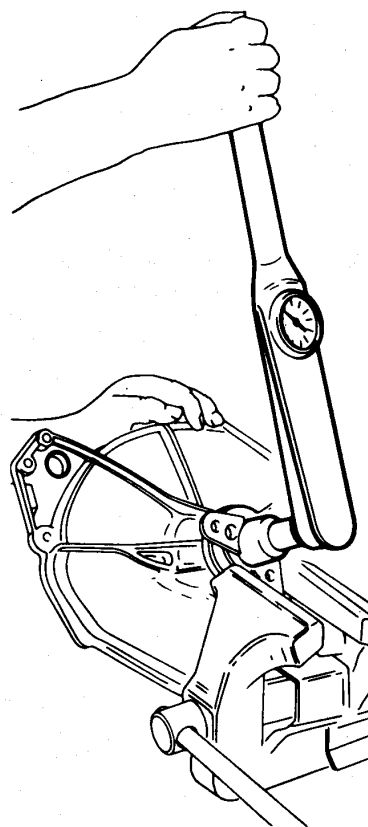

e. Reinstall bush ① and boot ②.

CLUTCH

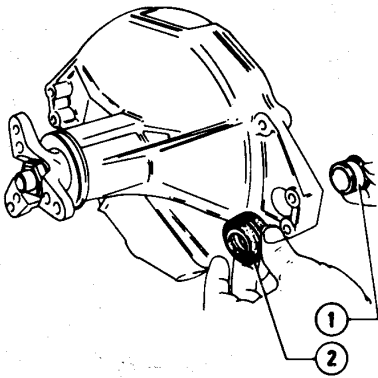

- 1 Bush for speeds engagement and selection rod
- 2 Boot

DOUBLE-PLATE CLUTCH

REMOVAL

1. Clutch cover removal

Operate as per "Single-Plate Clutch with "Drawn" Diaphragm Spring - Disassembly - Clutch Cover Removal.

To remove propeller shaft connecting fork, make use of puller A.3.0600.

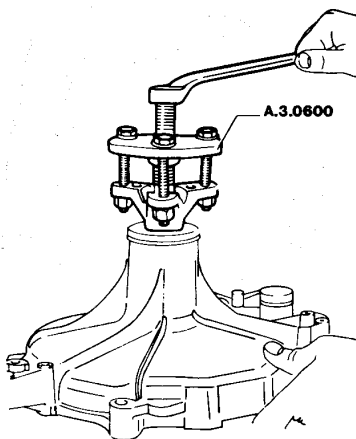

2. Clutch unit disassembly

a. If not present, carry out markings between flywheel ① and pressure plates bodies ② and ③.

Release and remove the screws with washers securing rear pressure plate body ③ to flywheel ①.

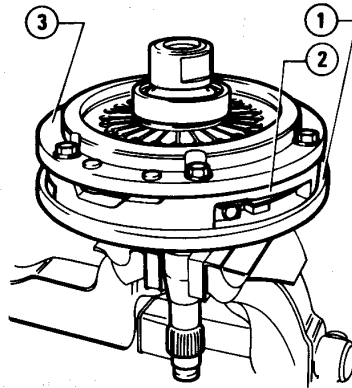

- 1 Flywheel
- 2 Intermediate pressure plate body
- 3 Rear pressure plate body

b. Withdraw rear pressure plate body ① with the related thrust bearing ② and clutch plate ③.

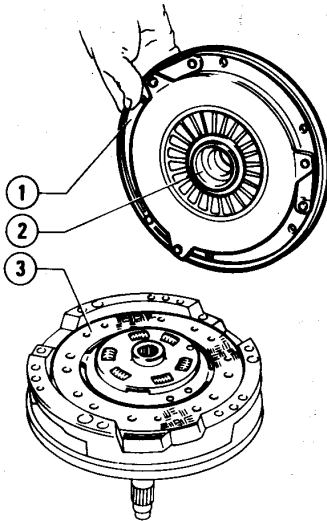

- 1 Rear pressure plate body
- 2 Thrust bearing
- 3 Rear clutch plate

c. Separate intermediate pressure plate body ③ and clutch plate ② from flywheel ①.

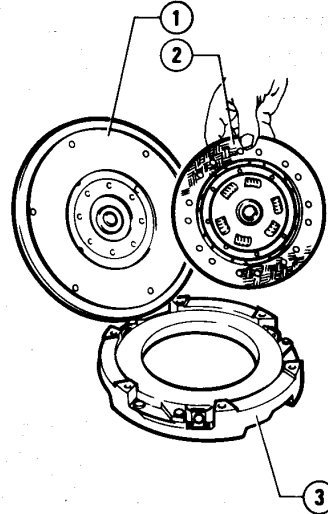

- 1 Flywheel
- 2 Front clutch plate
- 3 Intermediate pressure plate body

d. If necessary, withdraw speed gear main shaft centering bearing ③ from shaft ②, by means of suitable puller.

CLUTCH

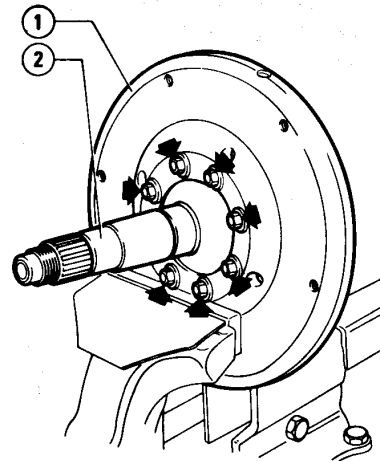
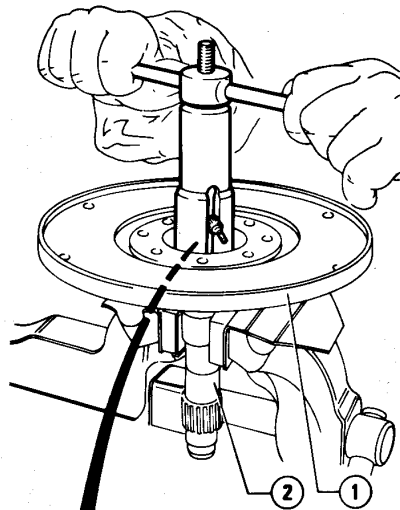

- 1 Clutch flywheel
- 2 Clutch shaft

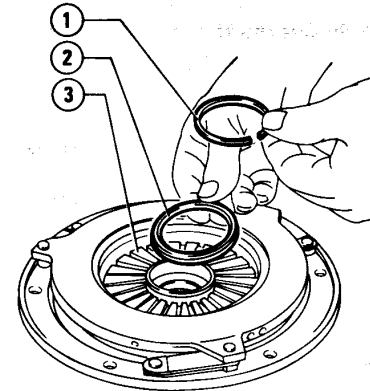

- 1 Retaining ring
- 2 Ring
- 3 Diaphragm spring

c. Remove bearing (2) from rear pressure plate body and recover spring (1).

3. Thrust bearing removal

- a. Set rear pressure plate body as per figure, then slightly press on it to overcome the reaction of bearing Belleville spring and remove retaining ring (1).
- b. Remove ring (2) securing thrust bearing to diaphragm spring (3).

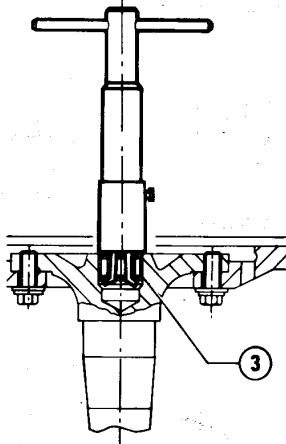

- 1 Clutch flywheel
- 2 Clutch shaft
- 3 Needle bearing

e. If necessary, unscrew and remove the screws with related washers which secure flywheel (1) to shaft (2); separate shaft from flywheel.

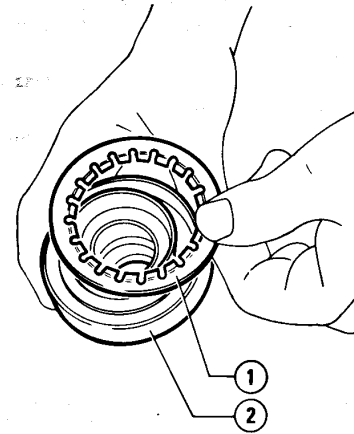

- 1 Belleville spring
- 2 Thrust bearing

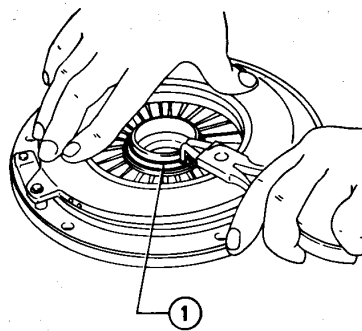

4. Removal of clutch cover bearings

Operate as per "Single-Plate Clutch with "Drawn" Diaphragm Spring - Disassembly - Removal of Clutch Cover Bearings.

CLUTCH

CHECKS AND INSPECTIONS

For the base checks, refer to: "Single-Plate Clutch with "Drawn" Diaphragm Spring - Checks and Inspections".

As regards the specific components of Double-Plate Clutch, comply with the following:

1. Clutch plate

Check wear degree of both driven plates.

CAUTION:

In the event of malfunctions identified on one plate only, the replacement of both plates is however required.

2. Pressure plate body

For this type of clutch, no grindings nor repair operations are to be executed for both pressure plates bodies.

As a consequence, in the event of excessive wear of deep scratches on both bodies, the whole unit must be replaced.

3. Clutch flywheel

For grinding tolerances, refer to "Service Data and Specifications".

REASSEMBLY

1. Insertion of clutch cover bearing

To reinstall bearings, operate as per: "Single-Plate Clutch with "Drawn" Diaphragm Spring - Reassembly - Insertion of Clutch Cover Bearing".

2. Thrust bearing reassembly

To reassemble thrust bearing, reverse the order of disassembly.

3. Clutch unit reassembly

- Refer to "Single-Plate Clutch with "Drawn" Diaphragm Spring - Reassembly - Clutch Unit Reassembly - steps a. - b."
- Install front clutch plate ① on flywheel ②.

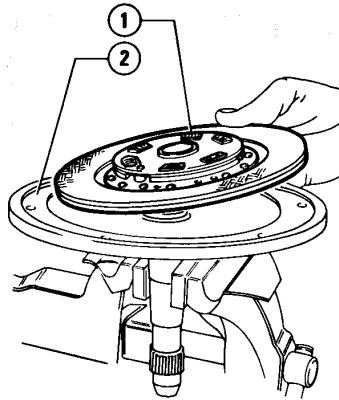

- Front clutch plate
- Clutch flywheel

- Install intermediate pressure plate body ① (complying with counter-marks executed when disassembling) and rear clutch plate ②.

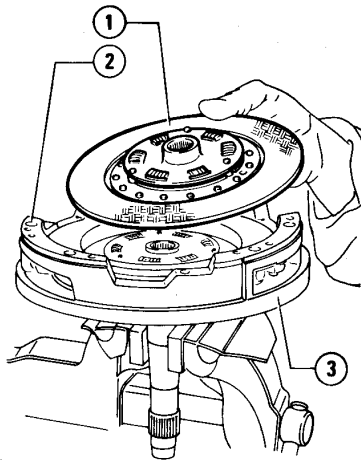

- Intermediate pressure plate body
- Rear clutch plate
- Clutch flywheel

- By means of tool A.4.0205, align hubs grooves of the two clutch plates.

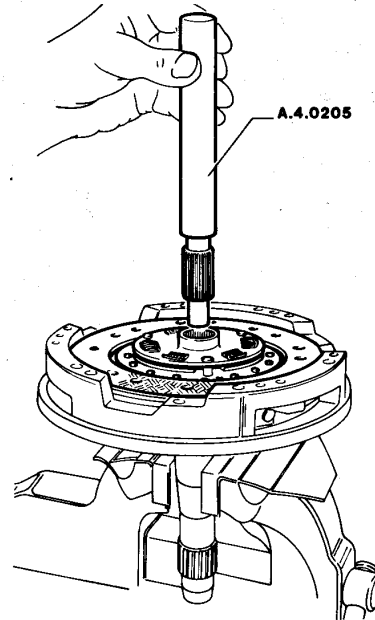

- Position pressure plate body ②, complete with thrust bearing ① complying with the countermarks executed when disassembling.

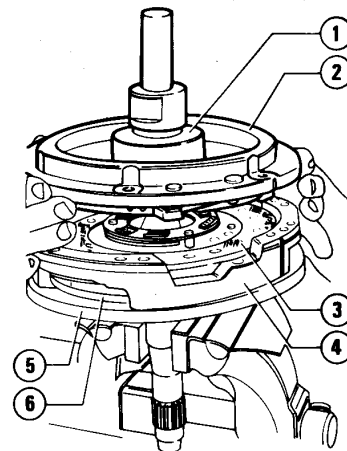

- Thrust bearing
- Rear pressure plate body
- Rear clutch plate
- Intermediate pressure plate body
- Clutch flywheel
- Front clutch plate

CLUTCH

f Insert screws ① securing pressure plate bodies to clutch flywheel, secure them according to the specified sequence, then, by means of tool A.4.0205, tighten the screws to the prescribed torque.

T: Tightening torque
Screws securing pressure plate to clutch flywheel

18 to 22 N·m
(1.8 to 2.2 kg·m
13.0 to 15.9 ft·lb)

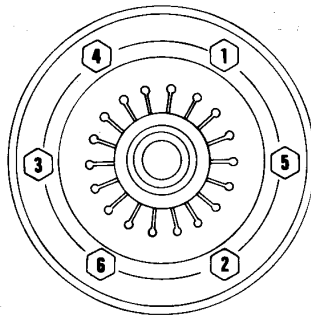
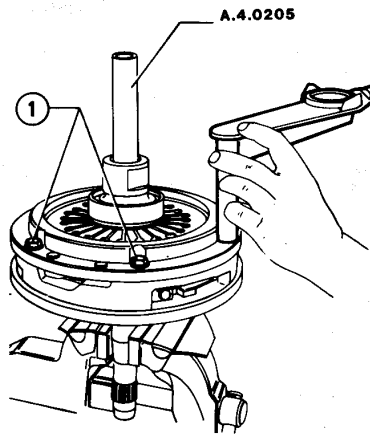

1 Screws

g. After tightening to the prescribed torque, make sure that pressure plate bodies and clutch plates mate perfectly and are coplanar to clutch flywheel.

To carry out verification, visually check that clearance "A" (shown in figure), due to diaphragm spring action, occurs in the vicinity of the taking up devices. This condition is necessary to guarantee the clutch unit disengagement travel.

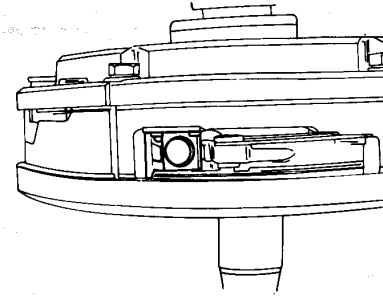

h. Withdraw tool A.4.0205.

4. Clutch cover reassembly

Ressemble clutch cover by proceeding as per: "Single-Plate Clutch with "Drawn" Diaphragm Spring - Reassembly - Clutch Cover Reassembly".

CLUTCH

SERVICE DATA AND SPECIFICATIONS

GENERAL SPECIFICATIONS

FLUIDS AND LUBRICANTS

Single-plate clutch with "pushed" diaphragm spring

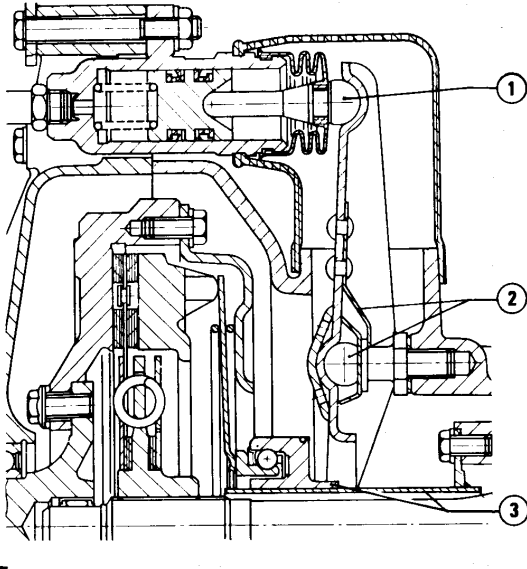

Single-plate clutch with "drawn" diaphragm spring and double-plate clutch

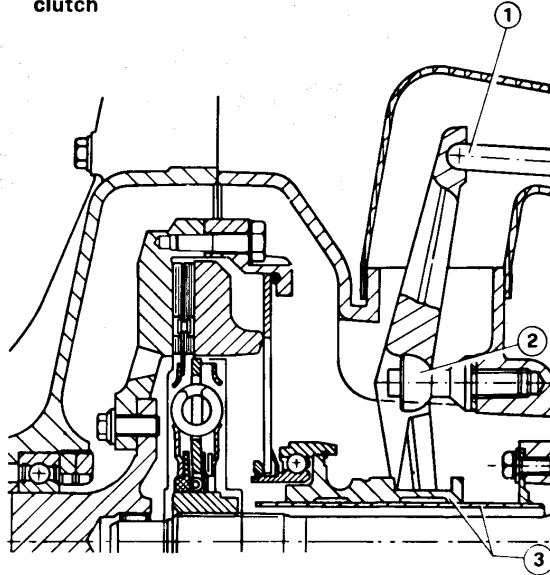

Application	Type	Name	Q.ty
<p>① Spherical seat and clutch operating cylinder push rod (1 and 2)</p> <p>② Rubber washer on spherical pin for clutch disengagement fork ①</p> <p>② Spherical pin and clutch disengagement fork spherical seat (2)</p> <p>③ Thrust bearing seat and clutch disengagement fork (1 and 2)</p>	GREASE	<ul style="list-style-type: none"> - AGIP Grease 33FD - IP Autogrease FD Std. No. 3671-69833/34 	-
Propeller shaft rear joint spherical seat	GREASE	ISECO Molykote BR2 Std. No. 3671-69841	5 cm ³ 0.3 cuin
Clutch hydraulic system filling (1 and 2)	FLUID	<ul style="list-style-type: none"> - AGIP Brake Fluid Super HD - ATE "Blau S" - IP Auto Fluid F.R. Std. No. 3681-69905 <p>CAUTION: Product harmful to paint. Keep it away from paint on view</p>	-

(1) For single-plate clutch with "pushed" diaphragm spring

(2) For single-plate clutch with "drawn" diaphragm spring and for double-plate clutch

CLUTCH

SEALANTS

Single-plate clutch with "pushed" diaphragm spring

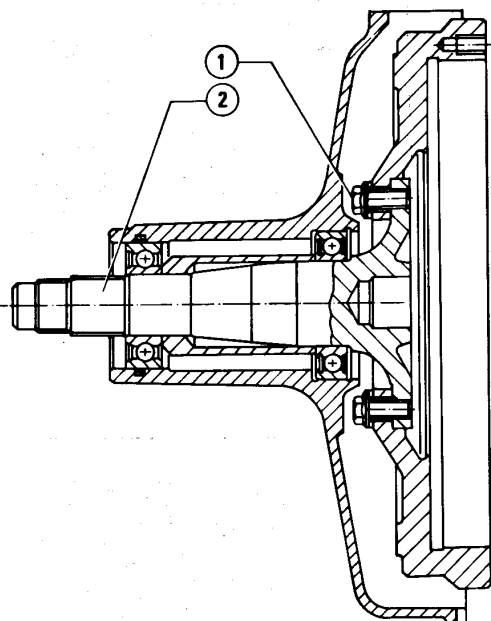

Single-plate clutch with "drawn" diaphragm spring and double-plate clutch

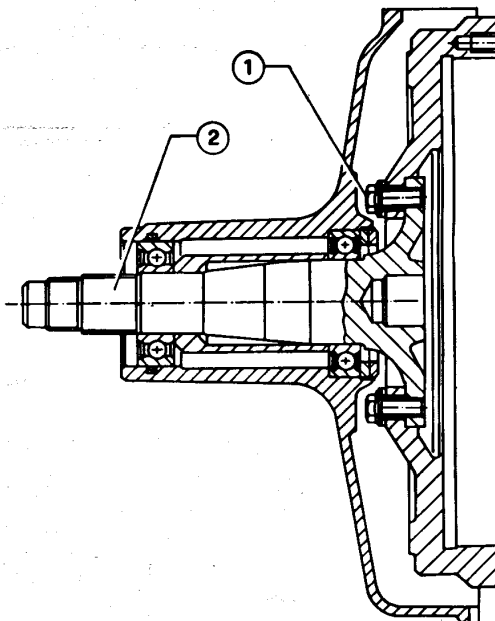

Application	Type	Name	Q.ty
① Threading of screws securing clutch shaft to flywheel - See note ①	SEALING COMPOUND	LOCTITE Stud Lok (Red) Std. No. 3524-00002	
② Clutch shaft splined tang for propeller shaft connecting fork See note ①	SEALING COMPOUND	LOCTITE 242 (Blue) Std.No. 3524-00010	-

(1) Before applying sealing compound, remove any trace of old compound by swabbing and blowing the surfaces concerned. Remove grease from surfaces with trichloroethylene and clorothene.

CLUTCH

CHECKS AND ADJUSTMENTS

SINGLE-PLATE CLUTCH FLYWHEEL WITH "PUSHED" DIAPHRAGM SPRING

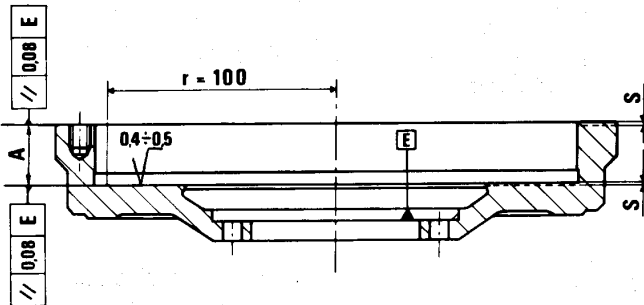

Clutch diameter	215 mm (8.46 in)	200 mm (7.87 in)
Dimensions		
<p>Rectification</p> <p>Removal of material on driven plate support plane must be such that the dimension between driven plate support plane and clutch cover is within the A value.</p> <p style="text-align: right;">A mm (in)</p> <p>Should dimension A be out of tolerance, remove material also from support plane of clutch cover.</p>	<p>22.5 + 0.2 (0.89 + 0.01)</p>	<p>25 + 0.2 (0.98 + 0.01)</p>
<p>Tolerances</p> <ul style="list-style-type: none"> - Parallelism error between driven plate support plane and clutch shaft connection plane (measured on a radius with "r" length) // mm (in) - Parallelism error between clutch cover support plane and clutch shaft connection plane // mm (in) - Roughness of driven plate support plane $\sqrt{\mu\text{m}}$ 	<p>0.08 (0.003)</p> <p>0.08 (0.003)</p> <p>0.4 to 0.5</p>	<p>0.08 (0.003)</p> <p>0.08 (0.003)</p> <p>0.4 to 0.5</p>

CLUTCH

SINGLE-PLATE CLUTCH FLYWHEEL WITH "DRAWN" DIAPHRAGM SPRING

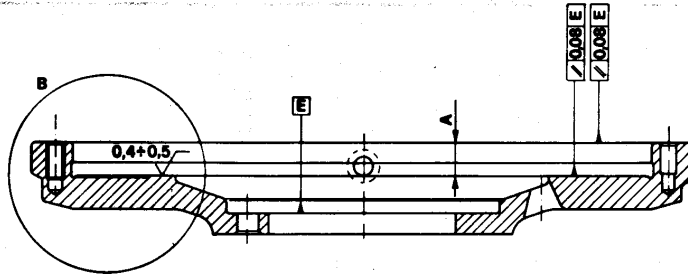

Clutch diameter	215 mm (8.46 in)	
Dimensions		Item B
<p>Rectification Removal of material on driven plate support plane must be such that the dimension between driven plate support plane and clutch cover is within the A value.</p> <p style="text-align: right;">A mm (in)</p> <p>Should dimension A be out of tolerance, remove material also from support plane of clutch cover.</p>	<p>12.5 + 0.2 (0.49 + 0.01)</p>	
<p>Tolerances</p> <ul style="list-style-type: none"> - Parallelism error between driven plate support plane and clutch shaft connection plane ∥ mm (in) - Parallelism error between clutch cover support plane and clutch shaft connection plane ∥ mm (in) - Roughness of driven plate support plane √ μm 	<p>0.08 (0.003)</p> <p>0.08 (0.003)</p> <p>0.4 to 0.5</p>	

CLUTCH

DOUBLE-PLATE CLUTCH FLYWHEEL

Dimensions			
Removal of material from driven plate support plane and clutch cover, shown by the "S", dimension must be	S mm (in)	0.2 max (0.01)	
Maximum parallelism error between driven plate support plane and clutch shaft connection plane	// mm (in)	0.06 (0.0024)	
Roughness of driven plate support plane	$\sqrt{\mu\text{m}}$	0.4 to 0.5	

CLUTCH

DIMENSIONS (1)	
Pressure plate-flywheel static balancing (max out-of balance allowed)	g·cm (in·lb) 10 (0.0086)
Operating cylinder pushrod travel	
Single-plate clutch with "pushed" diaphragm spring: C = 11 to 12.7 mm (0.443 to 0.5 in)	Single-plate clutch with "drawn" diaphragm spring: C = 12.5 mm (0.49 in)

(1) Dimensions applicable to all versions with single-plate clutch

CLUTCH

TIGHTENING TORQUES [N·m (Kg·m; ft·lb)]

Clutch type Application	Single-plate with "pushed" diaphragm spring	Single-plate with "drawn" diaphragm spring	Double-plate
Screws securing propeller shaft coupling to clutch shaft fork	39 to 49 (4 to 5 28.9 to 36)	55 to 57 (5.6 to 5.8 40.5 to 41.9)	55 to 57 (5.6 to 5.8 40.5 to 41.9)
Screws securing pressure plate to clutch flywheel	13 to 16 (1.3 to 1.6 9.4 to 11.6)	13 to 16 (1.3 to 1.6 9.4 to 11.6)	18 to 22 (1.8 to 2.2 13 to 15.9)
Screws securing clutch shaft to flywheel (for sealant compounds refer to: "Sealants")	27 to 31 (2.7 to 3.2 19.5 to 23.1)	27 to 31 (2.7 to 3.2 19.5 to 23.1)	27 to 31 (2.7 to 3.2 19.5 to 23.1)
Nut securing propeller shaft connecting fork to clutch shaft	93 to 103 (9.5 to 10.5 68.7 to 75.9)	93 to 103 (9.5 to 10.5 68.7 to 75.9)	93 to 103 (9.5 to 10.5 68.7 to 75.9)
Screws securing clutch unit to differential-speed gear unit.	29 to 32 (2.9 to 3.3 21 to 23.9)	29 to 32 (2.9 to 3.3 21 to 23.9)	29 to 32 (2.9 to 3.3 21 to 23.9)
Hydraulic system pipe unions:	10 to 15 (1 to 1.5 7.2 to 10.8)	10 to 15 (1 to 1.5 7.2 to 10.8)	10 to 15 (1 to 1.5 7.2 to 10.8)
Hoses	8 to 10 (0.8 to 1 5.8 to 7.2)	8 to 10 (0.8 to 1 5.8 to 7.2)	8 to 10 (0.8 to 1 5.8 to 7.2)
Pipes	18.6 to 23.5 (1.9 to 2.4 13.7 to 17.3)	18.6 to 23.5 (1.9 to 2.4 13.7 to 17.3)	18.6 to 23.5 (1.9 to 2.4 13.7 to 17.3)
Screws securing speed gear-differential unit to lateral support small block	18.6 to 23.5 (1.9 to 2.4 13.7 to 17.3)	18.6 to 23.5 (1.9 to 2.4 13.7 to 17.3)	18.6 to 23.5 (1.9 to 2.4 13.7 to 17.3)

CLUTCH

TROUBLE DIAGNOSIS AND CORRECTIVE ACTION

Condition	Probable cause	Corrective action
<p>Clutch slips</p> <p>Symptoms:</p> <ul style="list-style-type: none"> - Vehicle does not respond to engine speed when accelerating - Wheel power insufficient when uphill driving - Abnormal increase of fuel consumption 	<p>Some trouble symptoms can be also due to engine malfunctions. First of all, determine whether trouble is caused by engine or clutch.</p> <p>Proceed as follows to test clutch slipping:</p> <ul style="list-style-type: none"> - engage parking brake - disengage clutch and change to 4th speed - accelerate, then gradually release clutch pedal: if car does not move and engine does not stop, clutch is slipping 	<ul style="list-style-type: none"> • Clutch plate gaskets too worn • Oil or grease present on gaskets • Diaphragm spring damaged or worn condition in correspondance with thrust bearing support area • Flywheel or pressure plate deformed • Pushrod of clutch operating cylinder does not return to initial position: Operating cylinder piston or master cylinder piston seized
<p>Clutch can not be easily disengaged</p> <p>Symptoms:</p> <p>Noise when changing speed (especially in low gear ratio)</p>	<p>Proceed as follows to check clutch disengagement:</p> <ul style="list-style-type: none"> - disengage clutch and change to Reverse speed - change to Neutral and accelerate progressively, keeping clutch pedal depressed - after a short interval, change to Reverse speed <p>If noise is heard when changing speed, clutch is dragging.</p>	<ul style="list-style-type: none"> • Wear or rust on splined section of clutch plate hub. • Oil leaks from master cylinder, operating cylinder and hydraulic system • Air in the hydraulic system • Pedal travel insufficient • Operating cylinder inefficient • Master cylinder inefficient



CLUTCH

Condition	Probable cause	Corrective action
Clutch can not be easily disengaged (continue)	<ul style="list-style-type: none"> • Clutch plate deformed or eccentric • Diaphragm spring fatigued • Oil in clutch plate gaskets 	<p>Replace clutch plate</p> <p>Replace diaphragm spring</p> <p>Replace clutch plate (if faulty, replace oil seal ring of main shaft)</p>
<p>Clutch chatters</p> <p>Symptoms:</p> <p>Clutch pedal chatters when vehicle is started and clutch still partially engaged</p>	<ul style="list-style-type: none"> • Clutch plate gaskets vitrified due to overheating • Oil or grease on clutch plate gaskets • Clutch plate gaskets deformed • Flywheel working surface worn or deformed • Pressure plate working surface worn or deformed • Gaskets rivets loose • Rubber supports of clutch-speed gear-differential unit loose or deteriorated • Diaphragm spring fatigued • Clutch shaft bearings damaged 	<p>Replace clutch plate</p> <p>Replace clutch plate</p> <p>Replace clutch plate</p> <p>Repair or replace flywheel</p> <p>Replace pressure plate</p> <p>Replace clutch plate</p> <p>Secure or replace supports</p> <p>Replace pressure plate</p> <p>Replace bearings</p>
Noisy clutch	<ul style="list-style-type: none"> • Thrust bearing inusable <p>Noisy disengagement:</p> <ul style="list-style-type: none"> • Thrust bearing a/o support damaged or not suitably lubricated <p>Noise when clutch is engaged:</p> <ul style="list-style-type: none"> • Gaskets rivets loose • Clutch plate gaskets cracked • Clutch plate springs fatigued • Clutch shaft bearings damaged 	<p>Replace thrust bearing</p> <p>Replace or lubricate thrust bearing a/o support</p> <p>Replace clutch plate</p> <p>Replace clutch plate</p> <p>Replace clutch plate</p> <p>Replace bearings</p>
Clutch jerks	<ul style="list-style-type: none"> • Oil or grease on clutch plate gaskets 	<p>Replace clutch plate (if faulty, replace main shaft oil seal ring).</p>

CLUTCH

Condition	Probable cause	Corrective action
Clutch jerks (continue) Symptoms: - Vehicle does not start smoothly	<ul style="list-style-type: none"> • Gaskets worn or rivets loose • Wear or rust on direct drive shaft a/o clutch plate splined sections • Flywheel a/o pressure plate friction surfaces worn or deformed • Supports of clutch-speed gear-differential unit loose or deteriorated 	Replace clutch plate Clean or replace (according to requirements) the direct drive shaft a/o clutch plate. Repair or replace flywheel a/o clutch cover. Secure or replace supports

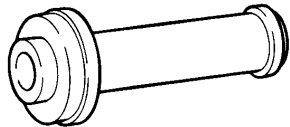
SPECIAL SERVICE TOOLS

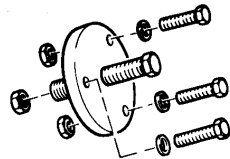
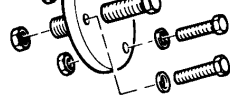
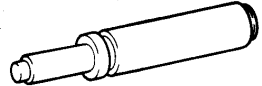
Tool P.M.	Name	Page Ref
A.3.0282	Driver for rear bearing 	12-19 12-25
A.3.0405	Driver for centering bush on flywheel-clutch shaft 	12-20 12-26
A.3.0477	Puller for propeller shaft connecting fork (for single-plate clutch with "pushed" diaphragm spring) 	12-16
A.3.0600	Puller for propeller shaft connecting fork (for single-plate clutch with "drawn" diaphragm spring and for double-plate clutch) 	12-22 12-28
A.4.0205	Tool for clutch plate centering 	12-21 12-27 12-30 12-31