

## FRONT SUSPENSION

# GROUP 21

## CONTENTS

DESCRIPTION .....	21-2	LOWER LINKS AND TORSION	
ANTI-ROLL BAR .....	21-3	BARS .....	21-10
Removal .....	21-3	Removal .....	21-10
Disassembly .....	21-3	Lower link .....	21-11
Inspection .....	21-3	Installation .....	21-13
Assembly .....	21-3	UPPER LINKS AND TIE RODS .....	21-14
Installation .....	21-3	Upper links .....	21-14
STEERING KNUCKLES AND		Tie rods .....	21-15
WHEEL HUBS .....	21-4	REAR CROSSMEMBER .....	21-16
Removal .....	21-4	Removal .....	21-16
Disassembly .....	21-5	Inspection .....	21-16
Inspection .....	21-7	Installation .....	21-16
Assembly .....	21-7	INSPECTION SPECIFICATIONS .....	21-17
Installation .....	21-8/1	General requirements .....	21-17
SHOCK ABSORBERS .....	21-9	Checks and adjustments .....	21-17
Removal .....	21-9	Tightening torques .....	21-22
Inspection .....	21-9	TROUBLESHOOTING .....	21-23
Installation .....	21-9	SPECIAL TOOLS .....	21-26

# FRONT SUSPENSION

## DESCRIPTION

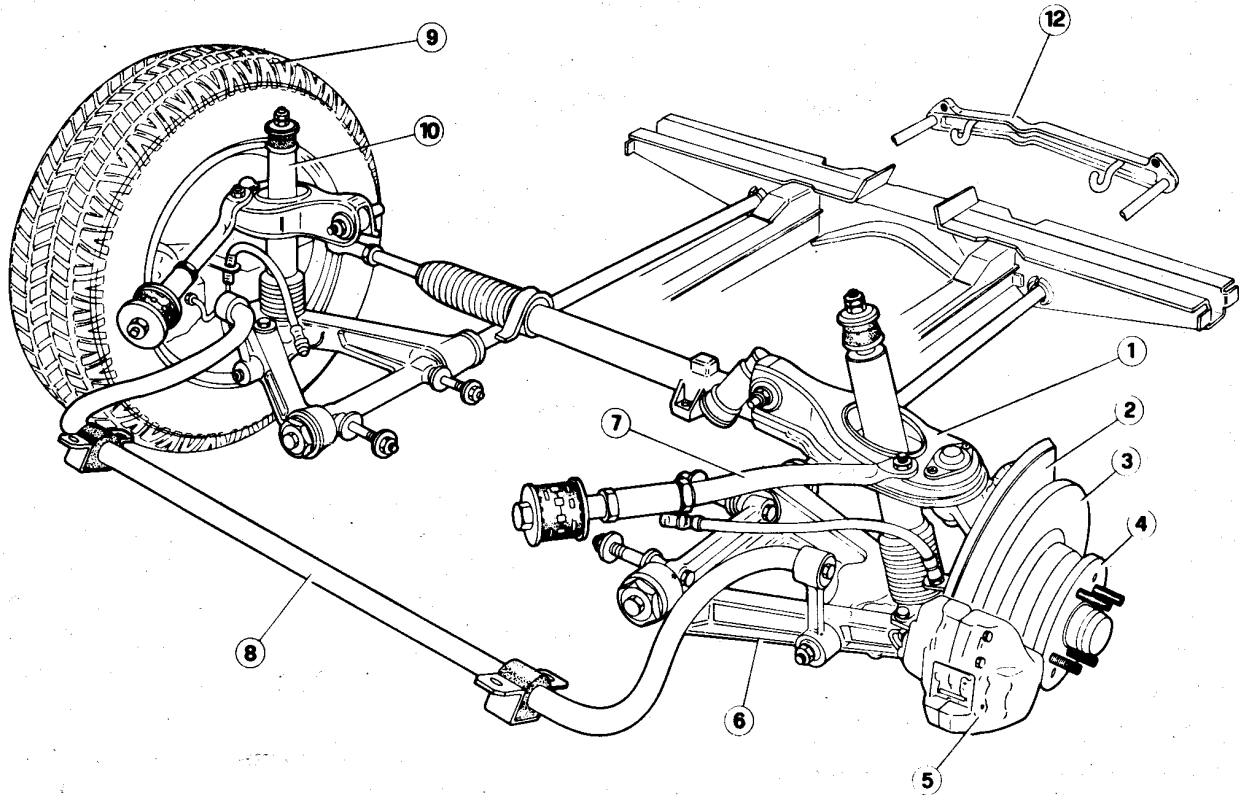

- |                 |                      |
|-----------------|----------------------|
| 1 Upper link    | 7 Tie rod            |
| 2 Splash guard  | 8 Anti-roll bar      |
| 3 Brake disc    | 9 Front wheel        |
| 4 Wheel hub     | 10 Shock absorber    |
| 5 Brake caliper | 11 Torsion bar       |
| 6 Lower link    | 12 Rear cross member |

Front suspension is independent, connected to body by transverse links. Two longitudinal torsion bars are connected at the front to the links and at the rear to the

chassis.

Front suspension also includes hydraulic double-acting shock absorbers connecting body and lower links and a anti-roll bar

improving stability on cornering. Link upward and downward movement is restricted by bump blocks secured to cross member.

# ANTI-ROLL BAR

## REMOVAL

Raise car on a lift, back off nuts ② and capscrews ③ and disconnect anti-roll bar ①.

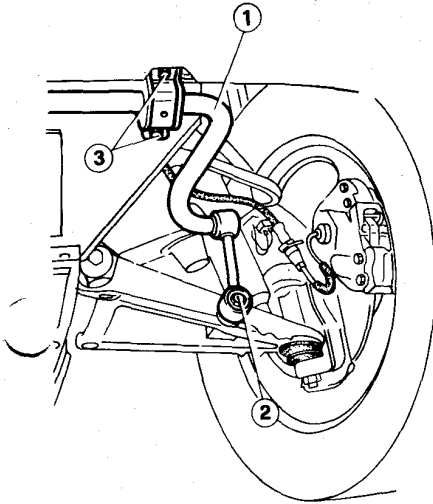

- 1 Anti-roll bar
- 2 Nut
- 3 Capscrews

## DISASSEMBLY

1. Apply markings on anti-roll bar and conn. rods.
2. Using a press, remove conn. rods from anti-roll bar.
3. Take off anti-vibration bushings ④ from conn. rod ③ and rubber cushions ① from anti-roll bar ②.

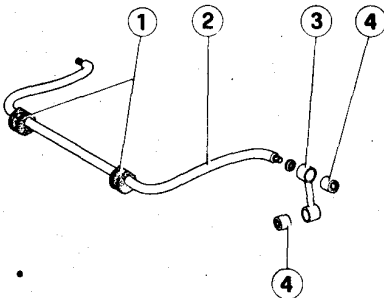

- 1 Rubber cushions
- 2 Anti-roll bar
- 3 Conn. rod
- 4 Anti-vibration bushing

## INSPECTION

Clean all parts.

1. Check that anti-roll bar and conn. rods are not damaged or bent and anti-vibration bushing seats are not worn; replace as necessary.
2. Check that rubber cushions, anti-vibration bushings and rubber components are not worn; replace damaged parts as necessary.

## ASSEMBLY

1. Lubricate inner surface of anti-roll bar support rubber cushions using the recommended grease (ISECO Ergon Rubber Grease no. 3; SPCA Spagraph; REINACH Sferul B2AR) and install on anti-roll bar.
2. Install anti-vibration bushings on conn. rods.
3. Clamp anti-roll bar in a vice and insert conn. rods on anti-roll bar spigots.

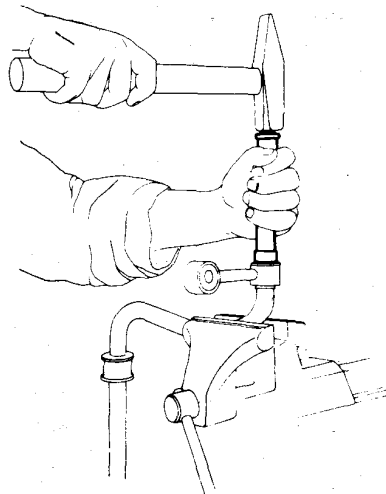

## INSTALLATION

Lubricate anti-roll bar supports on lower links using the recommended antiseize (R. GORI Never Seez) and install by reversing the removal sequence.

ⓧ : Tightening torques

Nut securing anti-roll bar conn.

rod to lower link

18 to 23 N · m

(1.8 to 2.3 kg · m)

(13.3 to 17 ft · lb)

Anti-roll bar pad support cap-screws

25 to 29 N · m

(2.5 to 3 kg · m)

(18.4 to 21.4 ft · lb)

# STEERING KNUCKLES AND WHEEL HUBS

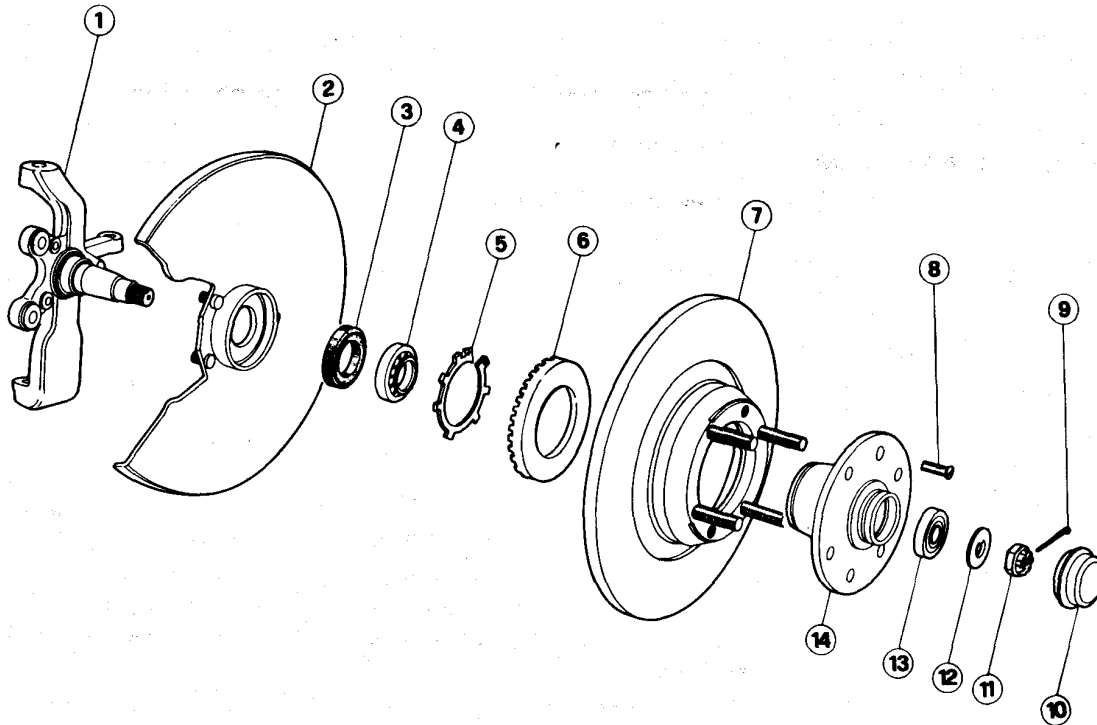

- 1 Steering knuckle
- 2 Splash guard
- 3 Seal
- 4 Inner bearing
- 5 Retaining ring (\*)

- 6 Impulse emitting wheel (\*)
- 7 Brake disc
- 8 Capscrew
- 9 Cotter pin
- 10 Hub cover

- 11 Nut
- 12 Washer
- 13 Outer bearing
- 14 Wheel hub

(\*) For vehicles equipped with (ABS) MARK II wheel antilock braking system only

## REMOVAL

1. Place car on a lift, operate parking brake, load car statically and slacken wheel nuts.
2. Back off capscrews (2) and disconnect shock absorber (1) from lower link (3).

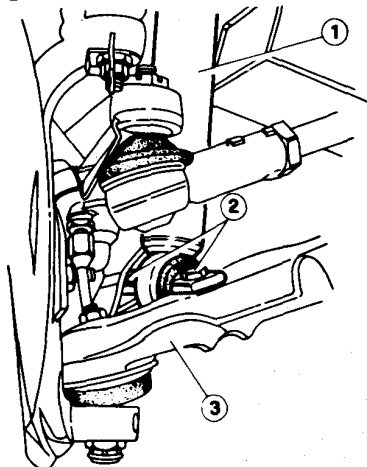

- 1 Shock absorber
- 2 Capscrews
- 3 Lower link

3. Raise car and support it at the front by means of stands and remove wheels.
4. Remove anti-roll bar (see: Anti-roll bar - Removal).
5. Vehicles equipped with (ABS) MARK II wheel antilock system only.
  - a. Back off screw (1) securing cable plate (2) to the upper link of the suspension.
  - b. Back off nuts (4) and remove the impulse pick-up (5), complete with support from the steering knuckle without disconnecting it electrically.
  - c. Put the impulse pick-up aside in a safe place, taking great care not to damage it and ensuring it does not hinder operations.

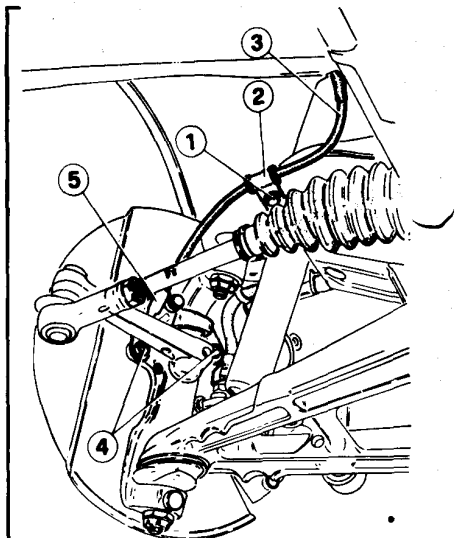

- 1 Screw
- 2 Cable plate
- 3 Impulse pick-up cable
- 4 Steering knuckle impulse pick-up support securing nut
- 5 Front impulse pick-up

## FRONT SUSPENSION

6. Position tools **A.2.0265** and **A.2.0069** on a column lift and insert in link seats and raise unit.

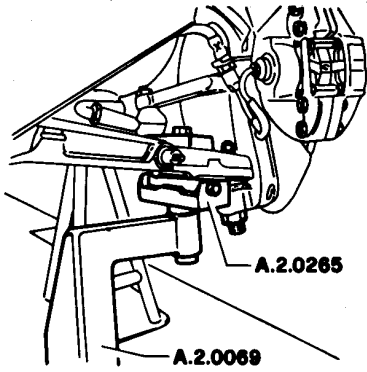

7. Remove cotter pin, back off nut and disconnect lower link ① from steering knuckle ② using tool **A.3.0377**.

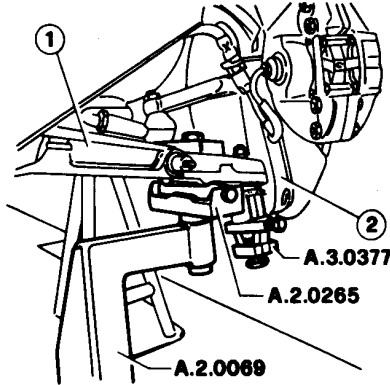

- 1 Lower link
- 2 Steering knuckle

## FRONT SUSPENSION

8. Unload torsion bar by lowering lift.
9. Disconnect brake fluid pipe from front caliper after draining brake fluid reservoir.

### WARNING:

Brake caliper may be removed from steering knuckle without disconnecting from hydraulic system, thereby avoiding having to refill and bleed the system.

10. Remove cotter pin, back off nut and disconnect steering linkage ① from steering knuckle ② using tool A.3.0156.

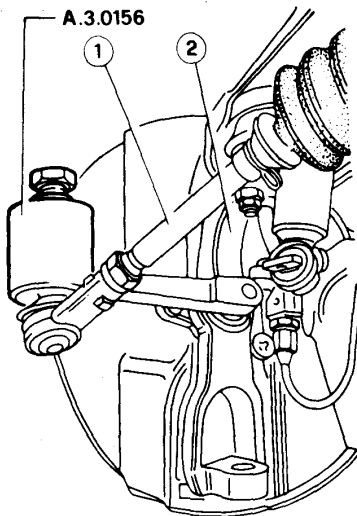

- 1 Steering linkage tie rod
- 2 Steering knuckle

11. Remove cotter pin, back off nut and disconnect upper link ① from steering knuckle ② using tool A.3.0377.

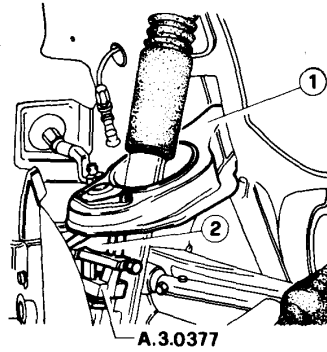

- 1 Upper link
- 2 Steering knuckle

12. Remove steering knuckle along with wheel hub.

### DISASSEMBLY

1. Install wheel hub unit in a vice; using a punch, push and take off brake pad pins ①, remove cross shaped spring ② and pads ③.

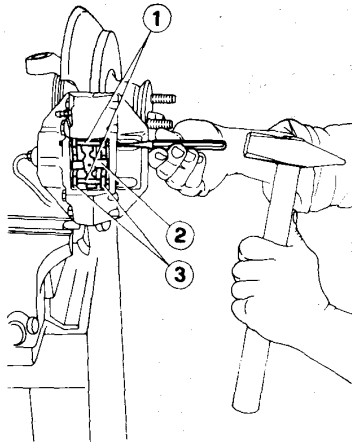

- 1 Pad pins
- 2 Cross spring
- 3 Brake pads

2. Slacken 2 capscrews ① securing brake caliper to steering knuckle ②.

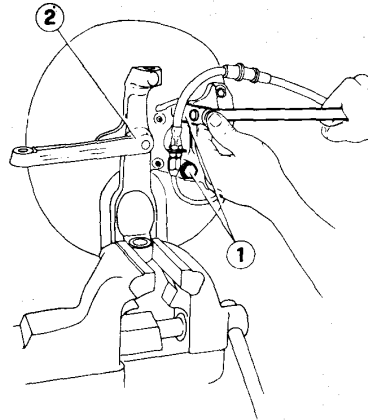

- 1 Brake caliper capscrews
- 2 Steering knuckle

3. Remove brake caliper assembly.

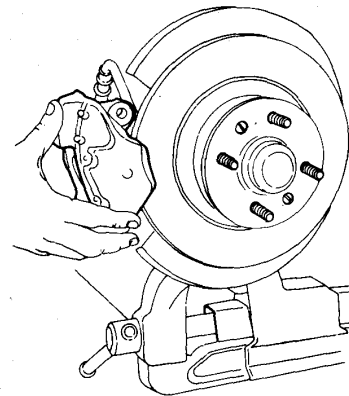

# FRONT SUSPENSION

4. Take off hub cover (4) and cotter pin (1).
5. Back off nut (2) and remove together with washer (3).

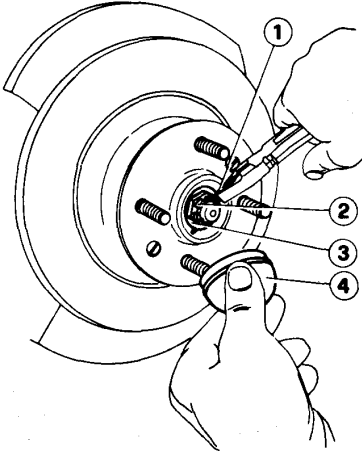

- 1 Cotter pin
- 2 Nut
- 3 Washer
- 4 Hub cover

6. Remove hub with brake disc and place on bench.

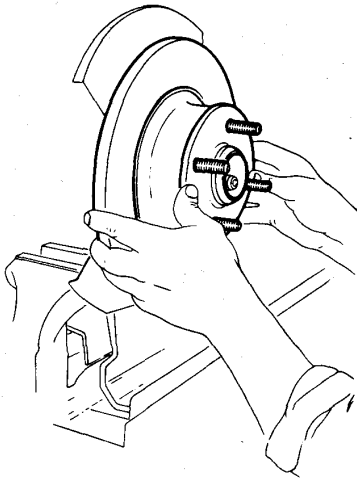

7. Remove splash guard (1) backing off 3 retaining nuts (2).

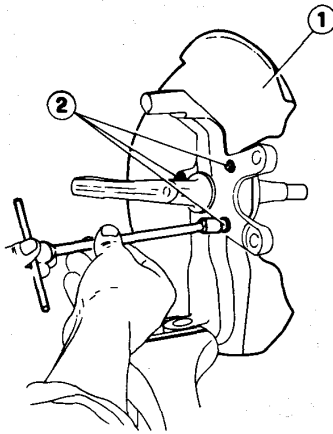

- 1 Splash guard
- 2 Retaining nuts

8. Vehicles equipped with (ABS) MARK II wheel antilock system only. Using suitable pliers remove the retaining ring (1) and separate the impulse emitting wheel (2) from the wheel hub.

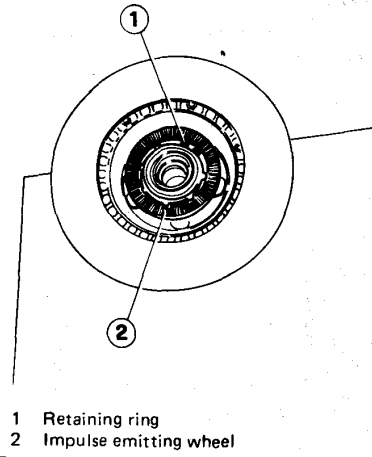

- 1 Retaining ring
- 2 Impulse emitting wheel

9. Remove outer bearing (1) from hub.

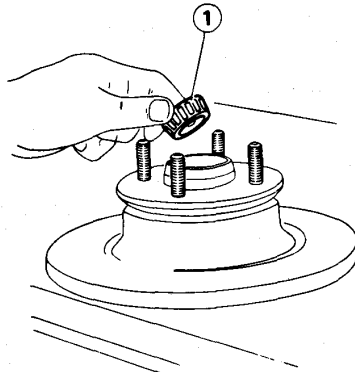

- 1 Outer bearing

**CAUTION:**  
Prevent shocks to bearing.

10. Back off 2 capscrews (1) securing wheel hub (2) to brake disc (3) and separate the two parts.

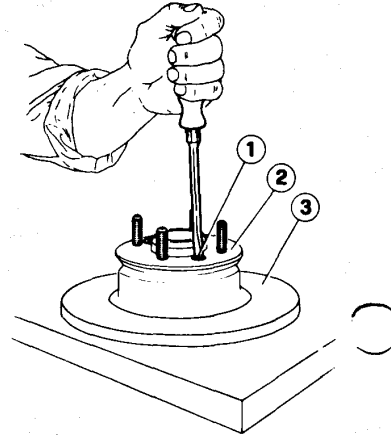

- 1 Capscrew
- 2 Wheel hub
- 3 Brake disc

11. Using a screwdriver, take off seal from hub. **When removed, the seal must be replaced.**

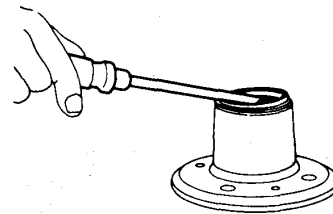

## FRONT SUSPENSION

12. Take off inner bearing ① from seat.

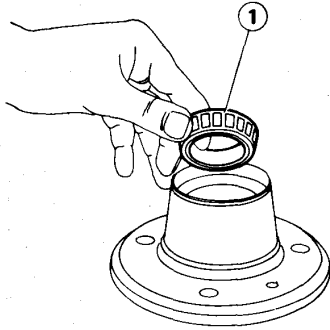

1 Inner bearing

13. Take off outer bearing cup.

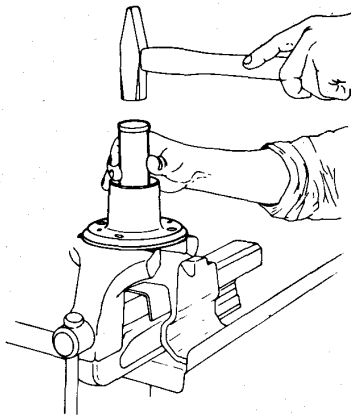

14. Take off inner bearing cup.

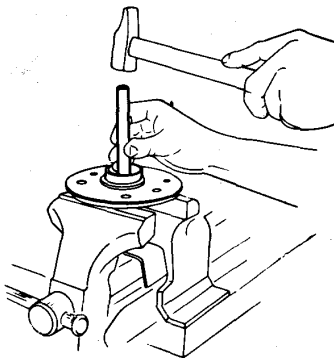

### INSPECTION

Thoroughly clean bearings and other parts and dry by blowing compressed air.

#### Wheel bearing

In case of pitting, roughness or ovality on race or taper roller surfaces, replace bearing.

#### CAUTION:

Bearings must be replaced in pairs, i.e. both inner and outer.

#### Steering knuckle and hub

Check wheel hub and steering knuckle; replace damaged parts as necessary.

### ASSEMBLY

1. Using inserter A.3.0329 with a press, install inner bearing cup on hub, pressing fully home.

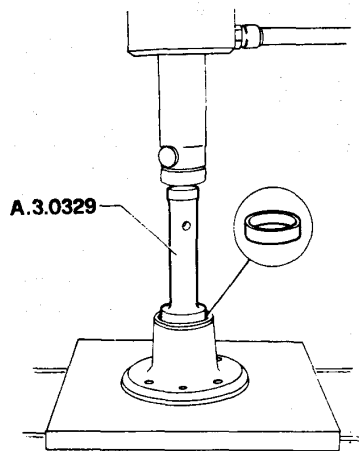

2. Using inserter A.3.0328 with a press, install outer bearing cup, pressing fully home.

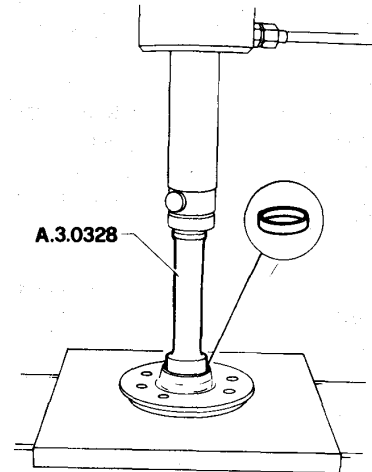

3. Lubricate bearing cups using bearing grease (AGIP Grease 33 FD or IP Autogrease FD) and pack hub recess with 50 g of grease. This quantity must not be exceeded otherwise bearing friction will result in overheating, grease leakage, etc.
4. Lubricate hub inner bearing using grease as per para. 3 and install.
5. Grease (ISECO Molykote BR2) the seal and install it on hub.

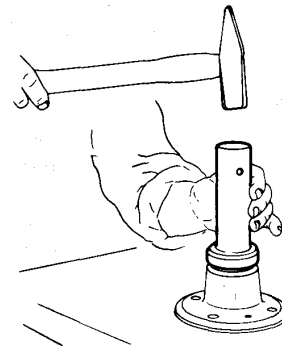



## FRONT SUSPENSION

6. Install and secure splash guard through 3 nuts.

7. Secure brake disc to hub through 2 capscrews.

8. Vehicles equipped with (ABS) MARK II wheel antilock system only.

Reassemble the impulse emitting wheel on the hub (having thoroughly cleaned it and checked for good condition) then secure it with the retaining ring.

9. Apply grease (ISECO Molykote BR2) to steering knuckle, threaded end, washer and retaining nut. Wet seal outer surface using the recommended oil (AGIP Rotra MP SAE 80W90 or IP Pontiax HD 80W90).

10. Install hub on steering knuckle and then install outer bearing, lubricated with grease as per para. 3, washer and nut.

11. Tighten nut to the specified torque and rotate hub to settle the bearings. Slacken nut and retighten to the specified torque.

### T : Tightening torques

Wheel hub nut, first tightening stage

20 to 24 N·m

(2 to 2.5 kg·m)

(14.8 to 17.7 ft·lb)

Wheel hub nut, second tightening stage

5 to 10 N·m

(0.5 to 1 kg·m)

(3.7 to 7.4 ft·lb)

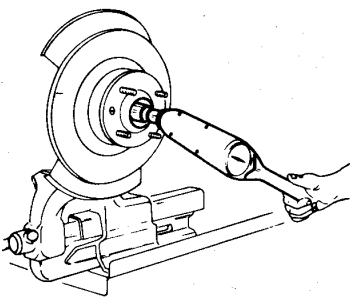

12. Vehicles not equipped with (ABS) MARK II wheel antilock system only.

a. Back off nut through 90° and insert cotter pin. If nut slot and steering knuckle hole are not aligned, further tighten nut as necessary to permit cotter pin insertion.

b. Settle bearings by tapping steering knuckle end using a mallet and check that washer is not locked (ensure that

washer can be moved by slight pressure prising with a screwdriver between washer and hub).

If washer is locked, remove cotter pin and back off nut to insert cotter pin in a hole perpendicular to the hole previously used. Tap steering knuckle end with a mallet and recheck washer fit.

c. Bend cotter pin and install hub cover.

13. Vehicles equipped with (ABS) MARK II wheel antilock system only. Check front hub bearing clearance.

### Front hub bearing clearance check

a. Install a comparator on a magnetic base (or suitable tool) so that it touches the steering knuckle axis (preload the comparator to 1 mm (0.04 in)).

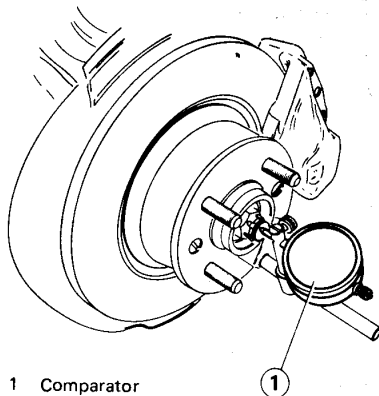

1 Comparator

b. Move the wheel hub axially (back and forth) and read the clearance indicated on the comparator. This clearance should come within specified values.

### Front hub bearing clearance:

G = 0.02 thru 0.12 mm

(0.0008 thru 0.005 in)

c. Re-position the cotter pin thus:

— If the clearance value is 0.02 thru 0.06 mm (0.0008 thru 0.002 in), back off nut until cotter pin is inserted.

— If the clearance value is 0.06 thru 0.12 mm (0.002 thru 0.005 in), screw on the nut until cotter pin is inserted.

d. Bend the cotter pin back and reassemble the hub cover.

14. Install brake caliper on steering knuckle by reversing the removal sequence and tighten two capscrews to the specified torque.

### T : Tightening torque

Brake caliper/steering knuckle capscrews

74 to 83 N·m

(7.5 to 8.5 kg·m)

(54.6 to 61.2 ft·lb)

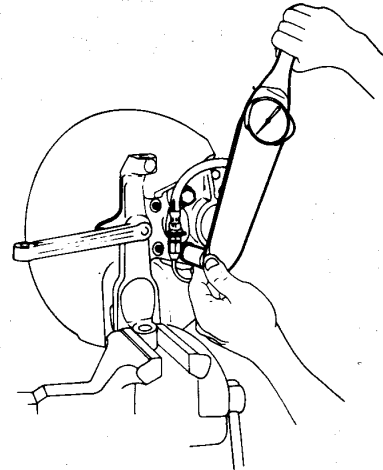

15. Insert pads ① in brake caliper ②, install cross spring ③ home and insert retaining pins ④.

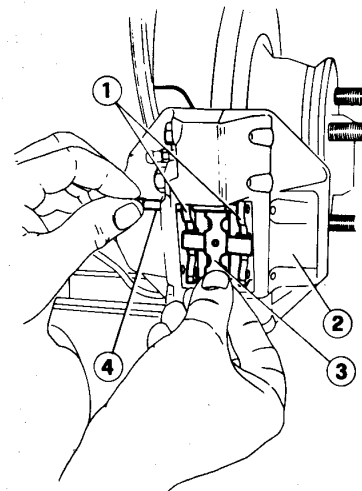

1 Pads  
2 Brake caliper  
3 Cross spring  
4 Retaining pin

# FRONT SUSPENSION

## INSTALLATION

1. Position tools **A.2.0265** and **A.2.0069** as previously specified and load torsion bar to connect steering knuckle to both lower and upper links.
2. Install by reversing the removal sequence and following the instructions detailed below.
3. Tighten nut securing upper link ball joint to steering knuckle to the specified torque (see Inspection Specifications - Tightening Torques).
4. Tighten the following parts to the specified torque.

**T** : Tightening torques

Steering link ball joint/steering knuckle nut

**45 to 55 N·m**  
(4.6 to 5.6 kg·lb)  
(33.2 to 40.6 ft·lb)

Lower link ball joint/steering knuckle nut

**45 to 55 N·m**  
(4.6 to 5.6 kg·m)  
(33.2 to 40.6 ft·lb)

5. Vehicles equipped with (ABS) MARK II wheel antilock system only.
  - a. Re-install the impulse pick-up in reverse order of removal, observing the following tightening torques.

**T** : Tightening torques

Steering knuckle - impulse pick-up support securing nuts

**9 thru 10 N·m**  
(0.9 thru 1 kg·m)  
(6.6 thru 7.4 ft·lb)

Suspension upper link - impulse pick-up cable plate securing screw

**9 thru 10 N·m**  
(0.9 thru 1 kg·m)  
(6.6 thru 7.4 ft·lb)

- b. Ensure that impulse pick-up cables have been well secured to their anchor points to avoid damage when vehicle is running.
  - c. Check the air gap between the impulse pick-ups removed and their respective impulse emitting wheels (see: Group 22 - Inspection Specifications - Checks and Adjustments - Adjustment of Air Gap between Impulse Pick-ups and Impulse Emitting Wheels).
6. Check car trim and front wheel geometry (see: Group 00 - Car Model Specific Manual - Car Trim Check).

# SHOCK ABSORBERS

## REMOVAL

1. Place the car on a platform lift.

### CAUTION:

Remove underhood components as necessary to gain access to nuts securing shock absorbers to body.

2. From engine compartment, detach shock absorbers from body by removing locknuts ①, nuts ②, washers ③ and associated rubber cushions.

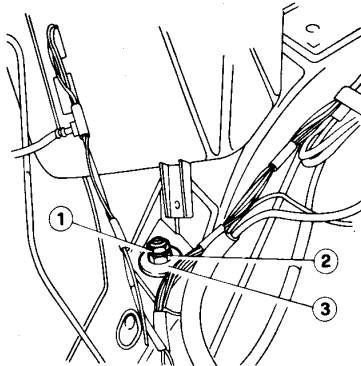

- 1 Locknut
- 2 Nut
- 3 Washer

3. Raise car and disconnect shock absorbers ① from lower links by backing off capscrews ②.

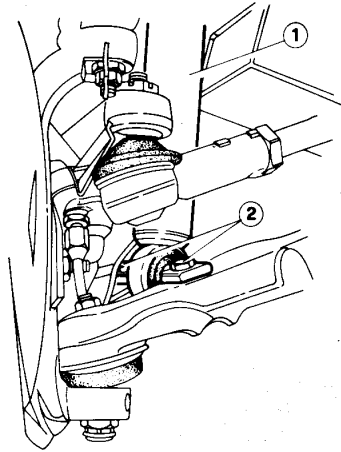

- 1 Shock absorbers
- 2 Capscrews

4. Remove shock absorbers.

## INSPECTION

1. Check shock absorbers and replace if affected by oil leakage.
2. If necessary, check shock absorbers settings (see Inspection Specifications - Checks and Adjustments). Replace as necessary.

## INSTALLATION

Install by reversing the removal sequence.

### T : Tightening torques

Shock absorber to body locknut

24 to 29 N · m

(2.4 to 3 kg · m)

(17.7 to 21.4 ft · lb)

Shock absorber to lower link cap-

screws

25 to 31 N · m

(2.5 to 3.2 kg · m)

(18.4 to 22.9 ft · lb)

LOWER LINKS AND TORSION BARS

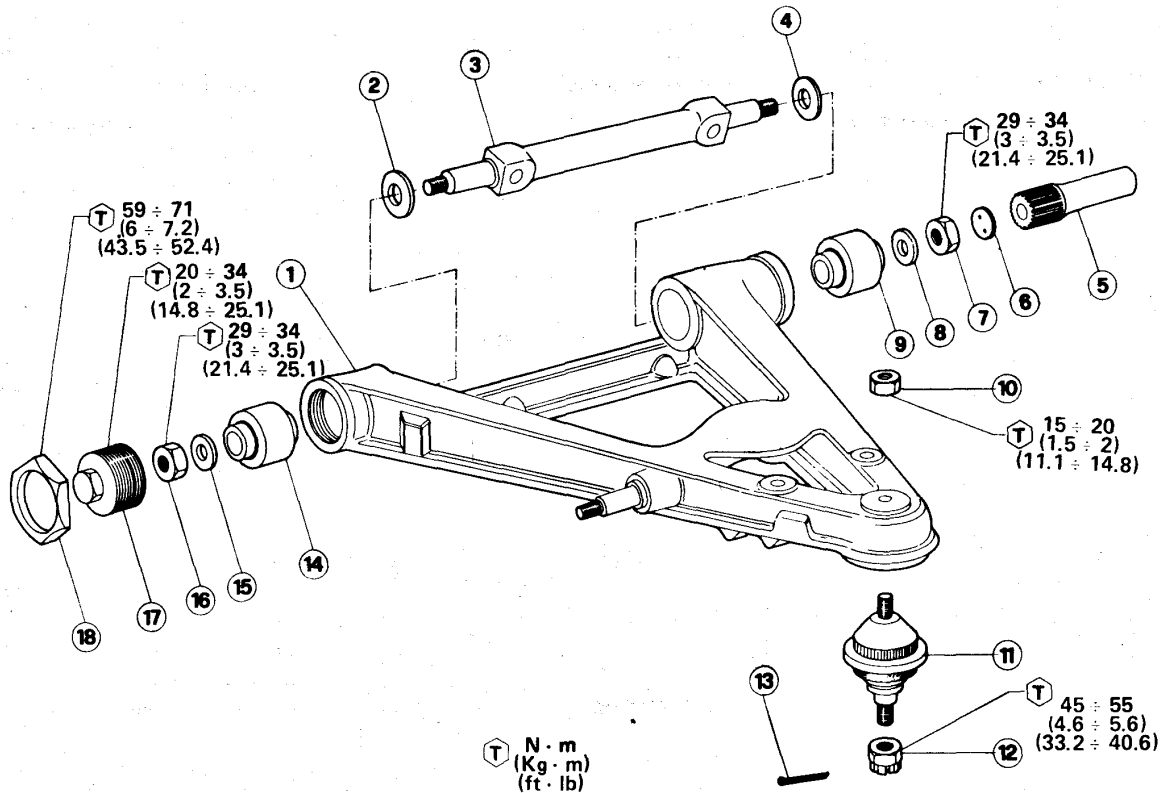

- 1 Lower link
- 2 Washer
- 3 Link support
- 4 Washer
- 5 Torsion bar
- 6 Plastic cover

- 7 Nut
- 8 Washer
- 9 Rear bush
- 10 Ball joint nut
- 11 Ball joint
- 12 Steering knuckle nut

- 13 Cotter pin
- 14 Front bush
- 15 Washer
- 16 Nut
- 17 Lockring
- 18 Retaining nut

REMOVAL

1. Proceed as specified in "Steering knuckles and Wheel hubs - Removal" up to para. 8 (excluding step 5).
2. Remove cover (1) from torsion bar seat (2).

3. Mark torsion bar at front and rear, install tool A.3.0374 and nut along with forcing screw A.3.0374/0001 and remove torsion bar from seat.

4. Back off bolts (1) and remove lower link (2) retrieving spacers.

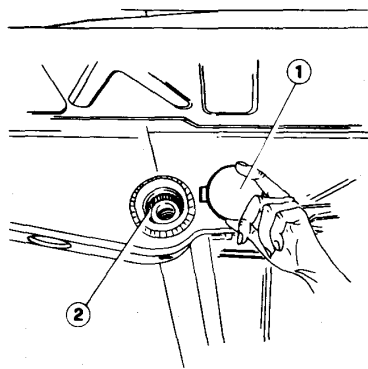

- 1 Cover
- 2 Torsion bar seat

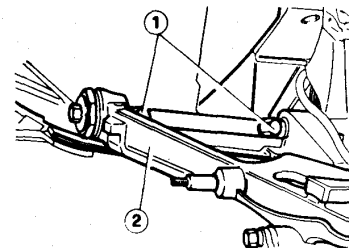
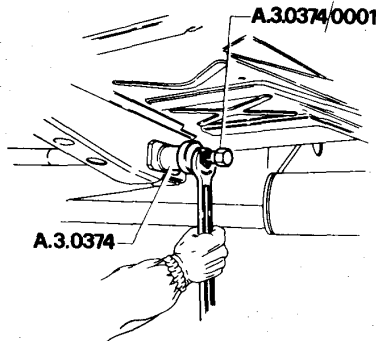

- 1 Bolts
- 2 Lower link

5. Take off torsion bar from the front.

## FRONT SUSPENSION

### CAUTION:

On cars provided with rear torsion bar connecting crossmember, carry out the following operations:

a. Proceed as specified under

"Steering knuckles and Wheel hubs - Removal" up to para. 8 (excluding step 5).

b. Back off and remove rear cover from torsion bar crossmember, mark bars and associated seats, install tool

A.3.0374 and take off torsion bar.

c. Remove lower link and torsion bar as specified in "Lower links and Torsion Bars - Removal", paragraphs 4 and 5.

## LOWER LINK

### DISASSEMBLY

1. Clamp lower link in a vice, remove plastic cover ① from torsion bar seat and back off nut ②.

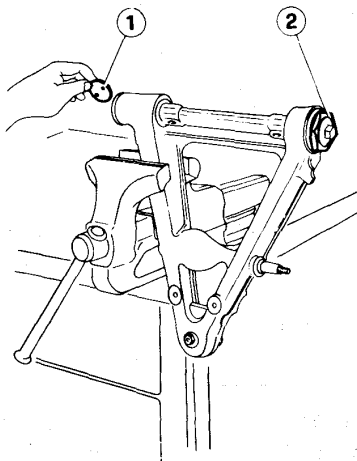

- 1 Plastic cover
- 2 Nut

2. Back off and remove locking ①.

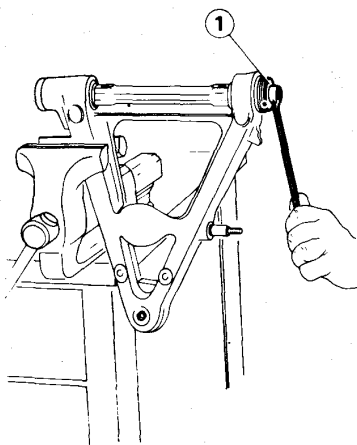

- 1 Lockring

3. Remove two nuts ① and associated washers preventing support ② rotation.

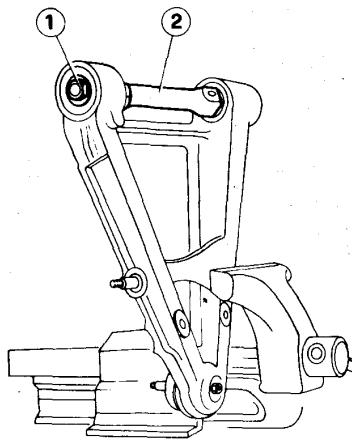

- 1 Nut
- 2 Link support

4. Install tool A.3.0372 on link support front threaded spigot, take off front bush and retrieve associated washer.

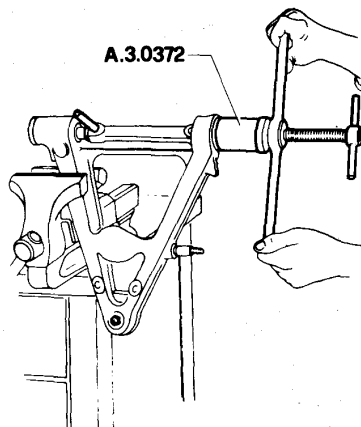

5. Position link support in seat, insert tool washer A.3.0373 in torsion bar seat and secure on link support threaded spigot through a nut.

Tighten tool A.3.0372 on link support front threaded spigot and take off rear bush ①.

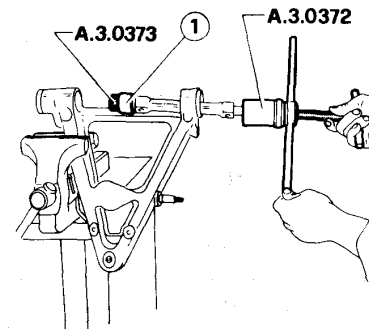

- 1 Rear bush

6. Back off ball joint ② nut ①.

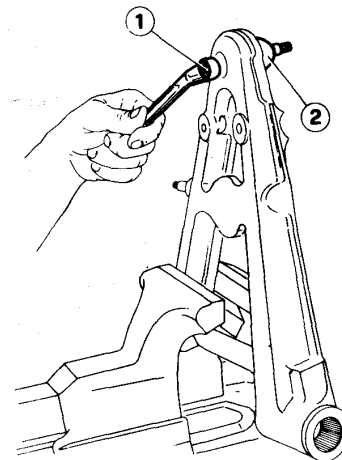

- 1 Nut
- 2 Ball joint

## FRONT SUSPENSION

7. Using tools **A.3.0576**, **A.3.0575** and **A.3.0441**, take off ball joint ① from link ②.

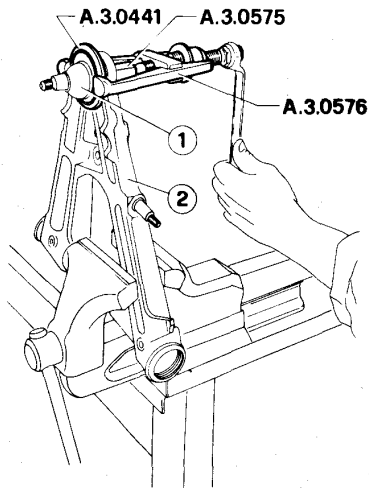

- 1 Ball joint  
2 Lower link

### INSPECTION

Clean all parts.

1. Check that link and support are not damaged or bent and that antivibration bushing seats are not worn; otherwise replace link or support.
2. Replace ball joint if roughness or excessive play is detected.
3. Check anti-vibration bushings for damage; in particular, ensure that rubber components are not worn; replace as necessary.

### ASSEMBLY

1. Using tools **A.3.0576**, **A.3.0562** and **A.3.0442**, insert ball joint ② lower link ①.

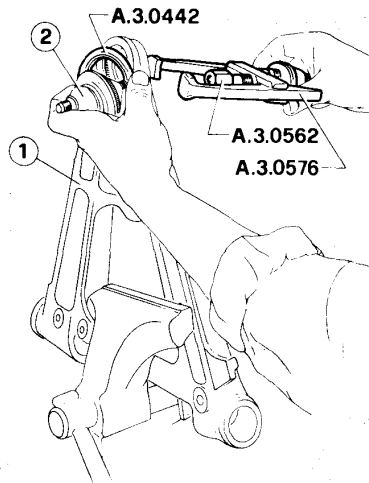

- 1 Lower link  
2 Ball joint

2. Tighten ball joint nut to the specified torque.

**T** : Tightening torque

Ball joint/lower link nut

15 to 19 N · m  
(1.5 to 2 kg · m)  
(11.1 to 14.0 ft · lb)

3. Lubricate bush/lower link recess using 6 g of recommended grease (ISECO Molykote Longterm no. 2).
4. Insert support ③, washer ② of tool **A.3.0372** and rear bush ① in link.

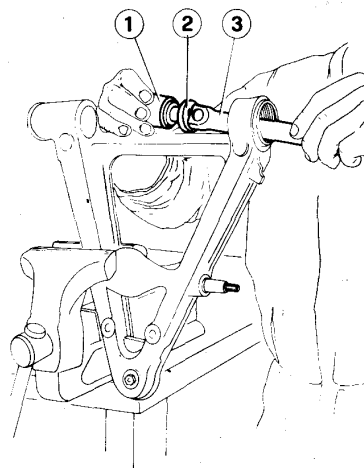

- 1 Rear bush  
2 Washer  
3 Link support

5. Tighten tool **A.3.0372** on link support rear threaded spigot and insert rear bush ①.

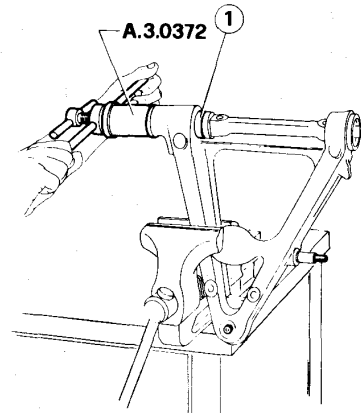

- 1 Rear bush

6. Retrieve tool **A.3.0372** and take off link support.
7. Install link support in seat with washers ①.

### CAUTION:

Washers must be positioned with chamfer facing toward support.

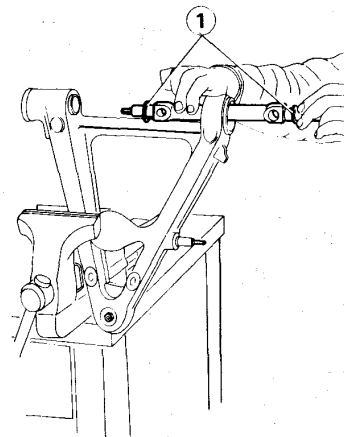

- 1 Washers

## FRONT SUSPENSION

8. Move support forward, insert front bush ① in support spigot, position tool washer A.3.0373 on support spigot threaded end and secure through a nut ②.

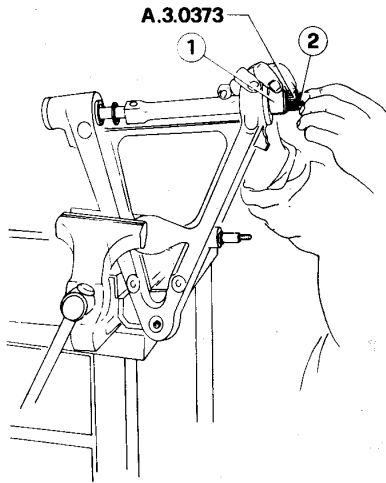

- 1 Front bush
- 2 Nut

9. Using tool A.3.0372 insert front bush in seat and remove tool.

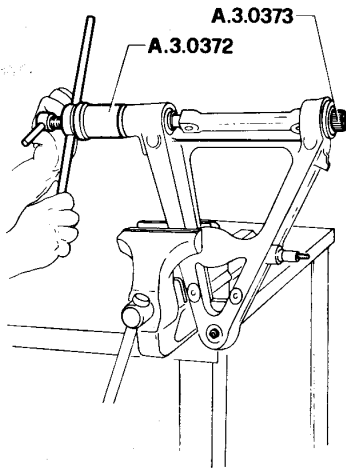

10. Insert two washers in threaded support ends, tighten two nuts to the specified torque, simultaneously preventing support rotation.

**T** : Tightening torque  
**Lower link support end nut**  
 30 to 34 N·m  
 (3 to 3.5 kg·m)  
 (22.1 to 25.1 ft·lb)

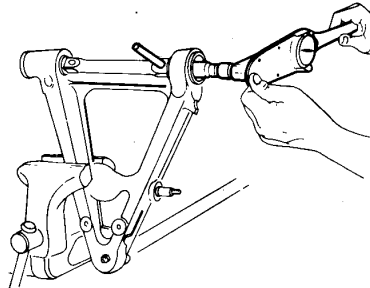

11. Tighten locking on link to the specified torque.

**T** : Tightening torque  
**Lower link locking**  
 20 to 34 N·m  
 (2 to 3.5 kg·m)  
 (14.8 to 25.1 ft·lb)

12. Tighten locking nut to the specified torque.

**T** : Tightening torque  
**Lower link locking nut**  
 59 to 70 N·m  
 (6 to 7.2 kg·m)  
 (43.5 to 51.6 ft·lb)

13. Insert plastic cover in torsion bar seat.

## INSTALLATION

Install by reversing the removal sequence and following the instructions given below.

- Before inserting torsion bar in seat, apply the recommended grease (R. GORI Never Seez) on seat and torsion bar splines.

### CAUTION:

Ensure that plastic cover is in position on lower link splined seat.

- On bar assembly align reference marks applied on disassembly, and match colour references.

Right bar - blue mark and letter D or R on front end.

Left bar - yellow mark and letter S or L on front end

- Tighten the following components to the specified torque.

**T** : Tightening torques  
**Lower link/body bolts**  
 64 to 74 N·m  
 (6.5 to 7.5 kg·m)  
 (47.2 to 54.6 ft·lb)

**Lower link ball joint/steering knuckle nut**  
 45 to 55 N·m  
 (4.6 to 5.6 kg·m)  
 (33.2 to 40.6 ft·lb)

# FRONT SUSPENSION

## UPPER LINKS AND TIE RODS

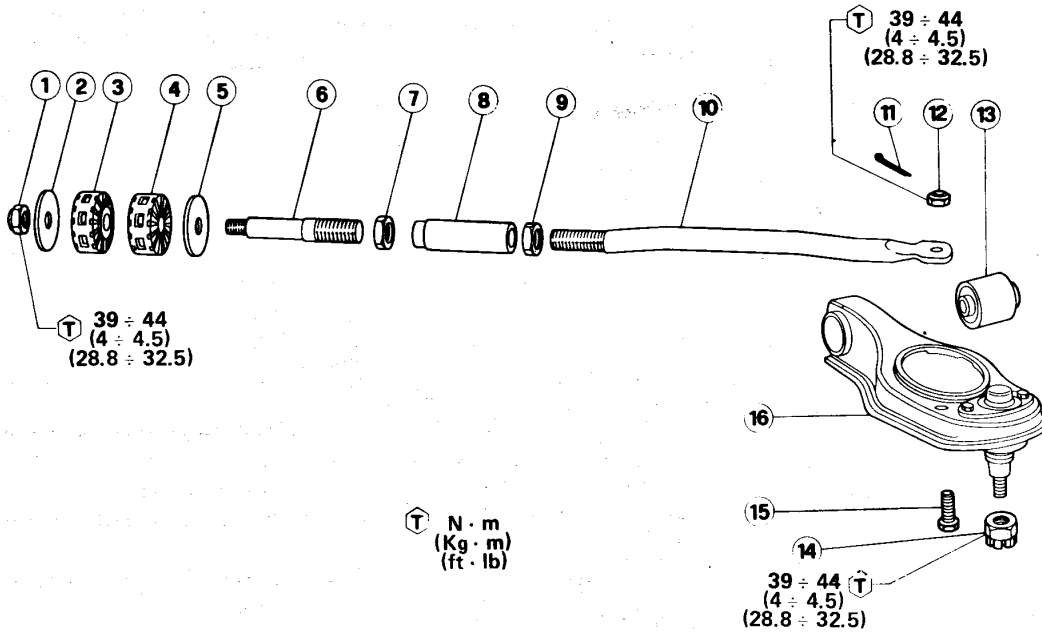

- 1 Nut
- 2 Washer
- 3 Bump block
- 4 Bump block
- 5 Washer
- 6 Outer pin

- 7 Nut
- 8 Bushing
- 9 Nut
- 10 Inner pin
- 11 Cotter pin
- 12 Self locking nut

- 13 Anti vibration bushing
- 14 Nut
- 15 Capscrew
- 16 Upper link

### UPPER LINKS

#### REMOVAL

1. Proceed as specified in "Steering knuckles and Wheel hubs - Removal" up to para. 6.
2. Remove cotter pin, back off nut and disconnect upper link ① from steering knuckle ② using tool A.3.0377.

3. Lower the column lift to unload lower link previously loaded.
4. Remove shock absorber (see Shock Absorbers - Removal).
5. Remove cotter pin ③, back off nut ② and disconnect tie rod ① from link ④.

link, disconnect tie rod from body as specified in "Tie rod - Removal".

6. Back off bolt ① and remove upper link.

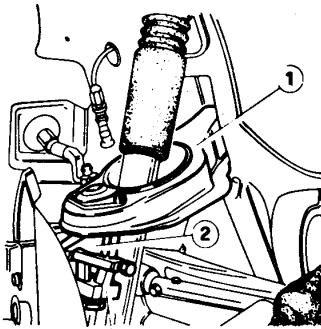

A.3.0377

- 1 Upper link
- 2 Steering knuckle

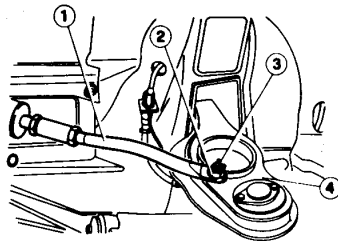

- 1 Tie rod
- 2 Nut
- 3 Cotter pin
- 4 Upper link

#### CAUTION:

On cars not provided with bolt securing upper link to tie rod, to remove

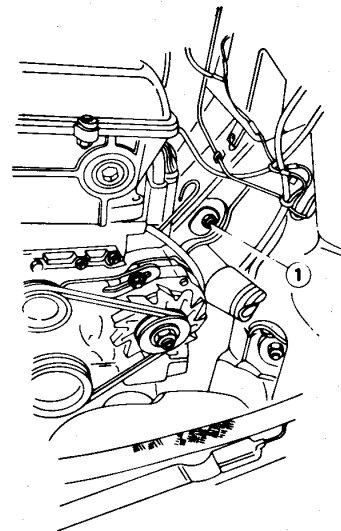

- 1 Bolt



## FRONT SUSPENSION

7. If necessary, take off anti-vibration bushing ① at the press using tools A.3.0367 and A.3.0368.

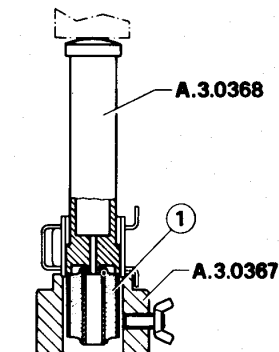

1 Anti-vibrating bushing

### INSPECTION

1. Check upper link for damage or distortion and anti-vibration bushing seat for wear; replace as necessary.
2. Replace ball joint if affected by roughness or excessive play.
3. Check that anti-vibration bushing is not damaged and in particular that the rubber portion is not worn; otherwise replace as necessary.

### INSTALLATION

1. If previously removed, install anti-vibration bushing ② using tool A.3.0367 at the press (with adapter ③ and lead in taper ①) and tool A.3.0368.

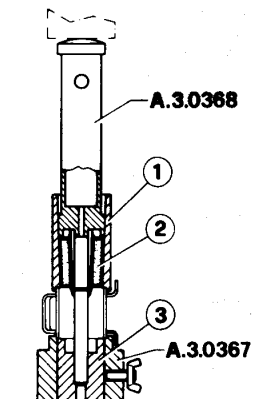

1 Lead-in taper  
2 Anti-vibration bushing  
3 Inner adapter

### CAUTION:

Insert anti-vibration bushing from chamfered side.

2. Apply the recommended lubricant (R. GORI Never Seez) on bolt securing upper link to body.
3. Connect upper link to body through securing bolt.
4. Raise upper link by 1 to 2 mm and tighten link bolt and tie rod nut to the specified torque.

### Tightening torques

Upper link/body securing bolt  
39 to 44 N·m  
(4 to 4.5 kg·m)  
(28.8 to 32.5 ft·lb)

Tie rod/upper link retaining nut  
39 to 44 N·m  
(4 to 4.5 kg·m)  
(28.8 to 32.5 ft·lb)

5. Install by reversing the removal sequence.
6. Vehicles equipped with (ABS) MARK II wheel antilock system only.
  - a. Re-install the impulse pick-up in reverse order of removal, observing the following tightening torques.

### Tightening torques

Steering knuckle - impulse pick-up support securing nuts  
9 thru 10 N·m  
(0.9 thru 1 kg·m)  
(6.6 thru 7.4 ft·lb)

Suspension upper link - impulse pick-up cable plate securing screw  
9 thru 10 N·m  
(0.9 thru 1 kg·m)  
(6.6 thru 7.4 ft·lb)

- b. Ensure that impulse pick-up cables have been well secured to their anchor points to avoid damage when vehicle is running.
- c. Check the air gap between the impulse pick-ups removed and their respective impulse emitting wheels (see: Group 22 - Inspection Specifications - Checks and Adjustments - Adjustment of Air Gap between Impulse Pick-ups and Impulse Emitting Wheels).

## TIE RODS

### REMOVAL

1. Place car on a platform lift.
2. From engine compartment, remove nut ① retrieving washer ② and rubber cushion.

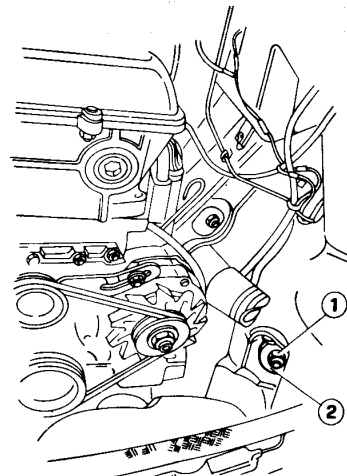

1 Nut  
2 Washer

3. Raise lift, remove cotter pin ① and back off nut ②. Remove tie rod ③.

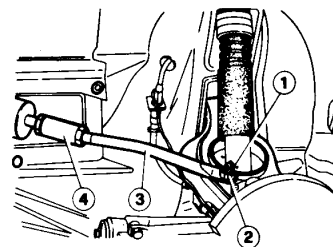

1 Cotter pin  
2 Nut  
3 Tie rod  
4 Bush

### CAUTION:

On cars not provided with a bolt securing tie rod to upper link, remove tie rod/upper link assy (see: Upper Link - Removal).

## FRONT SUSPENSION

### INSPECTION

Check tie rod for distortion or damage, and bump clocks for wear, replace any damaged parts as necessary.

### INSTALLATION

Install by reversing the removal sequence and following the instructions given below.

- Adhere to the specified tightening torques.

**T** : Tightening torque  
Tie rod to body nut  
Tie rod to upper link nut  
39 to 44 N·m  
(4 to 4.5 kg·m)  
(28.8 to 32.5 ft·lb)

- Check car trim and caster angle (See: Group 00 - Car Model Specification Manual - Car Trim Check).

## REAR CROSSMEMBER

For cars provided with torsion bar rear crossmember, carry out the following operations.

### REMOVAL

1. With disassembled torsion bars (see: Lower Links and Torsion Bars - Removal) disconnect exhaust piping flexible supports, back off bolts securing crossmember to chassis and take off crossmember.
2. If necessary, take off anti-vibration bushings at the press using a bolster **1** and a driver **2**.

### INSPECTION

Clean all parts.

1. Check that crossmember is not damaged or bent, torsion bar and anti-vibration bushing seats are not worn; replace crossmember if necessary.
2. Check that anti-vibration bushings are not damaged and, in particular, that rubber components are not worn; replace as necessary.

2. For installation reverse the removal sequence.

**T** : Tightening torques  
Torsion bar connecting crossmember nuts  
64 to 74 N·m  
(6.5 to 7.5 kg·m)  
(47.2 to 54.6 ft·lb)

### INSTALLATION

1. If previously removed, install anti-vibration bushings at the press using bolster **1**, lead-in taper **2** and driver **3**.

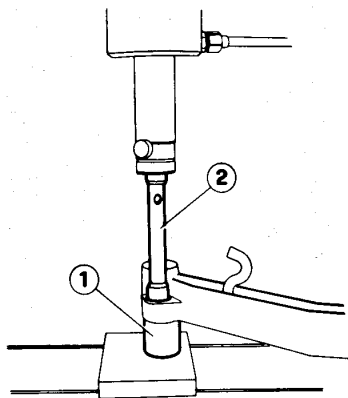

1 Bolster  
2 Driver

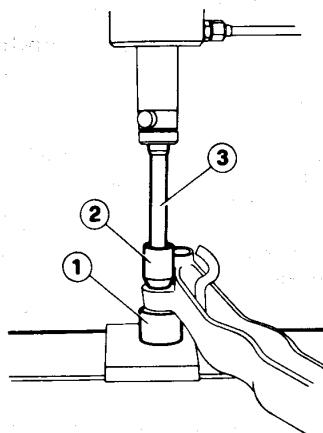

1 Bolster  
2 Lead-in taper  
3 Driver

## FRONT SUSPENSION

# INSPECTION SPECIFICATIONS

### GENERAL REQUIREMENTS

#### FLUIDS AND LUBRICANTS

Description	Type	Recommended product	Quantity
Wheel hub recess	GREASE	AGIP: Grease 33 FD IP: Autogrease FD Part. no. 3671-69833	50 g 1.76 oz.
Hub sealing ring lip and steering knuckle contact surface .	GREASE	ISECO: Molykote BR2 Part. no. 3671-69841	—
Hub sealing ring outer surface	OIL	AGIP: Rotra MP SAE 80W90 IP: Pontiax HD 80W90 Part. no. 3671-69408	Wet
Anti-roll bar cushion pad inner surface	GREASE	ISECO: Ergon Rubber Grease n. 3 SPCA: Spagraph REINACH: Sferul B2AR Part. no. 3671-69816	Wet
Torsion bar serrations Upper links to body screws Anti-roll bar supports (on lower links)	FLUID	R. GORI: Never Seez - Antigrippante Part. no. 3671-69850	—
Bush/lower link recess	GREASE	ISECO: Molykote Longterm n. 2 Part. no. 3671-69831	6 g 0.21 oz.

### CHECKS AND ADJUSTMENTS

#### TORSION BARS

Left bar yellow mark	Right bar blue mark	Length mm (in)	Diameter φ mm (in)	Minimum trim correction for a tooth mm (in)
Part. no.	Part. no.			
11611.21.505.00	11610.21.506.00	989 ± 2 (38.9 ± 0.1)	18.4 (0.72)	1.5 (0.06)
11656.21.505.00	11655.21.506.00	989 ± 2 (38.9 ± 0.1)	19.5 (0.77)	1.5 (0.06)
11691.21.505.00	11636.21.506.00	989 ± 2 (38.9 ± 0.1)	21.1 (0.83)	2 (0.08)
16200.21.X15.00	16200.21.X16.00 (*)	931 ± 2 (36.7 ± 0.1)	21.8 (0.86)	2 (0.08)
11642.21.505.00	11642.21.506.00	989 ± 2 (38.9 ± 0.1)	22.1 (0.87)	2 (0.08)
11907.21.505.00	11913.21.506.00	1108 ± 2 (43.6 ± 0.1)	22.6 (0.89)	2 (0.08)
16218.21.X15.00	16218.21.X16.00 (*)	931 ± 2 (36.7 ± 0.1)	22.8 (0.90)	2.5 (0.10)
11660.21.505.00	11659.21.506.00	989 ± 2 (38.9 ± 0.1)	23.4 (0.92)	2.5 (0.10)

\* For cars with a 3 piece welded sheet plate crossmember.

## FRONT SUSPENSION

### FRONT WHEEL GEOMETRY

For **Alfa 90** see Print no. PA36050000000 - Workshop Manual **Alfa 90** - Unit 00 - Mechanical Components and Body Maintenance - Wheel Alignment Data.

For **Alfa 75** see Print no. PA37140000000 - Workshop Manual **Alfa 75** - Unit 00 - Mechanical Components and Body Maintenance - Wheel Alignment Data.

	<b>Alfetta</b>	<b>Giulietta</b> <b>GTV 2.0</b>	<b>GTV 6 2.5</b>
Toe-out ( $\alpha$ )	9'	9'	9'
Caster ( $\gamma$ ) (Max. difference between right and left wheels)	3° ± 30' 20'	3° 30' ± 30' 20'	3° 30' ± 30' 20'
Camber ( $\beta$ ) (Max. difference between right and left wheels)	-20' ± 30' 40'	-30' ± 30' 40'	1° ± 30' 40'

### VEHICLE TRIM

For **Alfa 90** see Print no. PA36050000000 - Workshop Manual - **Alfa 90** - Unit 00 - Mechanical Components and Body Maintenance - Vehicle trim.

For **Alfa 75** see Print no. PA37140000000 - Workshop Manual **Alfa 75** - Unit 00 - Mechanical Components and Body Maintenance - Vehicle trim.

### Vehicle loading diagram for trim check

Note: Trim check must be carried out with vehicle in kerb weight conditions.

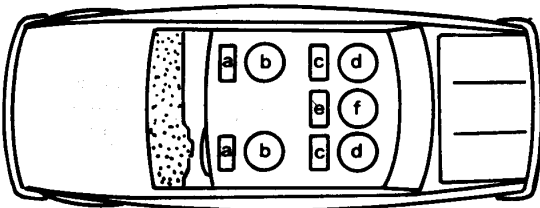

	<b>Alfetta</b>	<b>Giulietta</b>	<b>GTV 2.0</b> <b>GTV 6 2.5</b>
a	25 kg (55 lb)	25 kg (55 lb)	25 kg (55 lb)
b	50 kg (110 lb)	50 kg (110 lb)	50 kg (110 lb)
c	25 kg (55 lb)	25 kg (55 lb)	
d	50 kg (110 lb)	50 kg (110 lb)	
e			25 kg (55 lb)
f			50 kg (110 lb)

# FRONT SUSPENSION

## Front trim

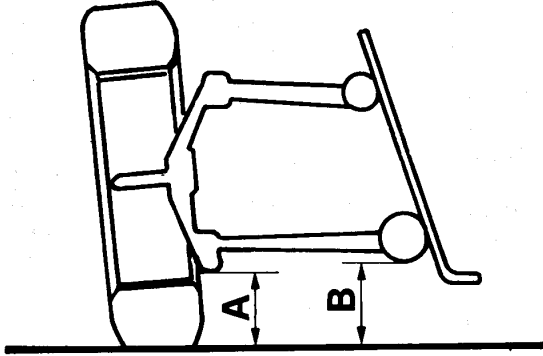

$$B - A = 44 \pm 5 \text{ mm (1.73} \pm 0.2 \text{ in)}$$

## Rear trim

— **Alfetta** and models featuring bump blocks co-axial with shock absorbers.

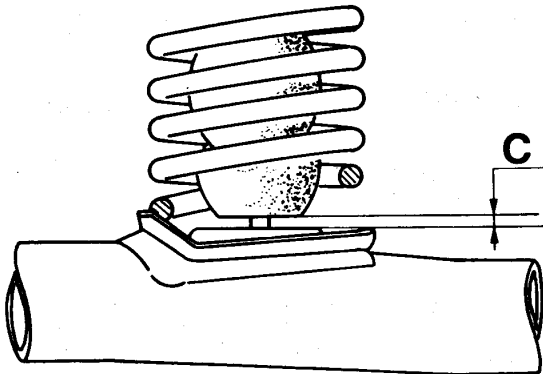

$$C = 44 \pm 5 \text{ mm (1.73} \pm 0.2 \text{ in)}$$

— **Giulietta** **GTV 2.0** and **GTV 625**

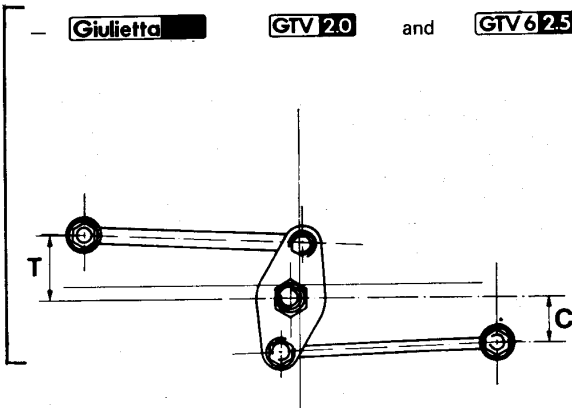

	<b>Giulietta</b>	<b>GTV 2.0</b> <b>GTV 625</b>
T	83 ± 5 mm (3.27 ± 0.2 in)	71 ± 5 mm (2.8 ± 0.2 in)
C	-13 ± 5 mm (-0.51 ± 0.2 in)	-25 ± 5 mm (-0.98 ± 0.2 in)

# FRONT SUSPENSION

## BASIC BAR REPLACEMENT

### Foreword

Front trim adjustment is accomplished by rotating the torsion bars with respect to reference notes on the front links and rear cross member.

The different number of serrations (35 at the front, 34 at the rear) allows small trim corrections (about 1.5 - 2 - 2.5 mm depending on bar diameter) to be made by repositioning by one tooth at both ends.

Consequently, torsion bar subdivision has been based on diameter rather than vehicle type. A mark, known as the "basic mark" has been put on both ends of the bars.

When operating on the bars, take care not to switch them over, by observing, during assembly, the following marks:

- left bar, yellow mark and letter S or L
- right bar, blue mark and letter D or R

### Basic bar installation

- a) Choose a basic bar having the same diameter as the one to be replaced.
- b) Trace the part no. by referring to the torsion bar table.
- c) Take a new bar from the storehouse then install it by aligning the references on the basic marks with those on the crossmember and lower link.
- d) Having completed installation, check

the trim as per normal procedure, bearing in mind that with a new torsion bar the trim value is 5 mm greater than the normal one.

e) In the event of incorrect trim, adjust by rotating the bar by some teeth.

The exact number of teeth by which the bar is to be rotated is obtained by dividing the trim difference by the minimum trim correction value corresponding to the bar diameter (see torsion bar table).

f) It is emphasized that for a **lower trim**, by rotating the left bar CCW and the right bar CW, **the trim value increases**. For **greater trim**: by rotating the left bar CW and the right bar CCW, the trim value decreases.

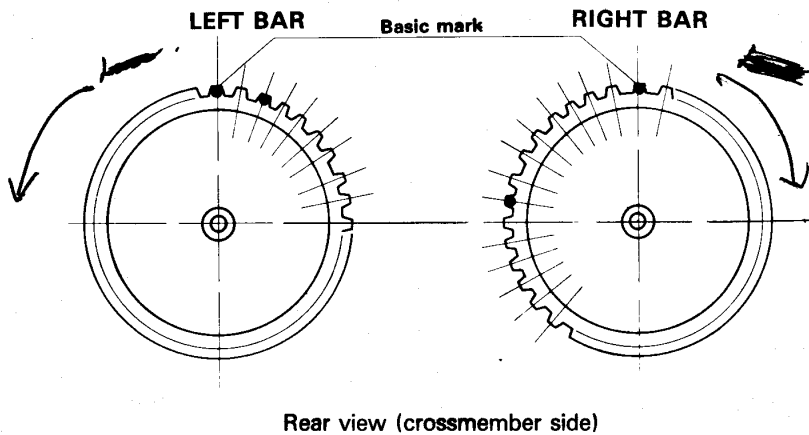

Rear view (crossmember side)

## FRONT SUSPENSION

### SHOCK ABSORBER CALIBRATION AND PAIRING





On all vehicles front and rear shock absorbers must be paired as indicated in the calibration table.

**CAUTION:**

In case of substitution, the shock-absorber mounted on the vehicle should always be replaced with those of the same Trade Mark (Spica or Boge).

**Front**

values in [N (kg)] (lb)

Car type	Alfa 90 Super Alfa 75 	Alfa 75  6V iniezione Alfa 75 turbo  ev 2.8  ev 3.0	Alfa 90 Alfa 90 Super Alfa 75 and  other models	Alfetta Giulietta	GTV 2.0 GTV 62.5	
Part. no.	161.18.21.072.04	161.18.21.072.03	113.21.21.072.01	116.50.21.070.01	113.19.21.072.01	
Low speed	Compression	140 to 220 (14.3 to 22.4) (31.5 to 49.5)	230 to 310 (23.4 to 31.6) (51.7 to 69.7)	170 to 250 (17.3 to 25.5) (38.2 to 56.2)	130 to 250 (13.3 to 25.5) (29.2 to 56.2)	230 to 310 (23.4 to 31.6) (51.7 to 69.7)
	Rebound	550 to 650 (56.1 to 66.3) (123.6 to 146.1)	550 to 650 (56.1 to 66.3) (123.6 to 146.1)	500 to 600 (51 to 61.2) (112.4 to 134.9)	250 to 440 (25.5 to 44.9) (56.2 to 98.9)	550 to 650 (56.1 to 66.3) (123.6 to 146.1)
High speed	Compression	550 to 670 (56.1 to 68.3) (123.6 to 150.6)	580 to 720 (59.1 to 73.4) (130.4 to 161.9)	450 to 590 (45.9 to 60.1) (101.2 to 132.6)	380 to 560 (38.7 to 57.1) (85.4 to 125.9)	580 to 720 (59.1 to 73.4) (130.4 to 161.9)
	Rebound	1600 to 1800 (163.1 to 183.5) (359.7 to 404.6)	1850 to 2050 (188.4 to 209) (415.9 to 460.8)	1400 to 1600 (142.7 to 163.1) (314.7 to 359.7)	1000 to 1370 (101.9 to 139.7) (224.8 to 308)	1850 to 2050 (188.4 to 209) (415.9 to 460.8)

**Rear**

values in [N (kg)] (lb)

Car type	Alfa 90 Alfa 90 Super Alfa 75 		Alfetta Giulietta	GTV 2.0 GTV 62.5	
Part. no.	162.00.25.072.02	(*) 162.00.25.072.05	116.00.25.070.23	113.19.25.072.00	
Low speed	Compression	110 to 190 (11.2 to 19.4) (24.7 to 42.7)	90 to 170 (9.2 to 17.3) (20.2 to 38.2)	70 to 170 (7.1 to 17.3) (15.7 to 38.2)	230 to 310 (23.4 to 31.6) (51.7 to 69.7)
	Rebound	110 to 190 (11.2 to 19.4) (24.7 to 42.7)	180 to 280 (18.3 to 28.5) (40.5 to 62.9)	110 to 290 (11.2 to 29.6) (24.7 to 65.2)	550 to 650 (56.1 to 66.3) (123.6 to 146.1)
High speed	Compression	420 to 520 (42.8 to 53) (94.4 to 116.9)	310 to 450 (31.6 to 45.9) (69.7 to 101.1)	240 to 410 (24.5 to 41.8) (54 to 92.2)	580 to 720 (59.1 to 73.4) (130.4 to 161.9)
	Rebound	1090 to 1270 (111.1 to 129.5) (245 to 285.5)	1060 to 1260 (108.1 to 128.4) (238.3 to 283.2)	890 to 1350 (90.7 to 137.6) (200 to 303.5)	1850 to 2050 (188.4 to 209) (415.9 to 460.8)

(\*) The A.R. part number 162.00.25.072.05 shock-absorbers substitute the A.R. part number 117.01.25.070.02. ones. The new type shock-absorbers can be installed on vehicles already equipped with old type ones.

In case of an old type shock-absorber replacement, it will be necessary to substitute the new upper rubber rebound bumper with the old one (if not damaged). Otherwise it is necessary the total replacement of the old shock-absorber pair.

# FRONT SUSPENSION

## FRONT WHEEL HUB BEARING CLEARANCE CHECK (\*)

- Slacken nuts securing front wheel concerned.
- Raise the front of the vehicle and rest it on stands; remove the wheel.
- Remove hub cover.
- Install a comparator on a magnetic base (or suitable tool) so that it touches the steering knuckle axis (preload the comparator to 1 mm (0.04 in)).

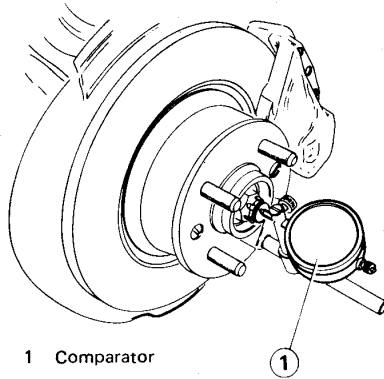

- Move the wheel hub axially (back and forth) and read the clearance indicated on the comparator.

This clearance should come within specified values.

**Front hub bearing clearance**  
**G = 0.02 thru 0.12 mm**  
**(0.0008 thru 0.005 in)**

(\*) Vehicles equipped with (ABS) MARK II wheel antilock braking system.

## TIGHTENING TORQUES

Description	[N·m (kg·m) (ft·lb)]
Nut, wheel hub (stage 1)	20 to 24 (2 to 2.5) (14.8 to 17.7)
Nut, wheel hub (stage 2)	5 to 10 (0.5 to 1) (3.7 to 7.4)
Nut, lower link support end	29 to 34 (3 to 3.5) (21.4 to 25.1)
Lockring, lower link	20 to 34 (2 to 3.5) (14.8 to 25.1)
Nut, lower link locking	59 to 71 (6 to 7.2) (43.5 to 52.4)
Nut, ball joint to lower link	15 to 20 (1.5 to 2) (11.1 to 14.8)
Nuts, lower link support to chassis	64 to 74 (6.5 to 7.5) (47.2 to 54.6)
Nut, lower link ball joint to steering knuckle	44 to 54 (4.5 to 5.5) (32.5 to 39.8)
Nut, upper link ball joint to steering knuckle	
— Rims with four securing screws	80 to 90 (8.2 to 9.2) (59 to 66.4)
— Rims with five securing screws	45 to 55 (4.6 to 5.6) (33.2 to 40.6)
Nut, upper link to chassis	39 to 44 (4 to 4.5) (28.8 to 32.5)
Nut, tie rod to chassis	39 to 44 (4 to 4.5) (28.8 to 32.5)
Nut, tie rod to upper link	39 to 44 (4 to 4.5) (28.8 to 32.5)
Nuts, torsion bar connecting crossmember	64 to 74 (6.5 to 7.5) (47.2 to 54.6)
Locknut, shock absorber to chassis	24 to 29 (2.4 to 3) (17.7 to 21.4)
Capscrews, shock absorber to lower link	25 to 31 (2.5 to 3.2) (18.4 to 22.9)
Nut, anti-roll bar conn. rod (on lower link)	18 to 23 (1.8 to 2.3) (13.3 to 17)
Capscrews, anti-roll bar cushion pads	25 to 29 (2.5 to 3) (18.4 to 21.4)
Capscrews, front brake caliper to steering knuckle	74 to 83 (7.5 to 8.5) (54.6 to 61.2)
Nut, steering link ball joint to steering knuckle	45 to 55 (4.6 to 5.6) (33.2 to 40.6)
Steering knuckle - impulse pick-up support securing nuts (1)	9 to 10 (0.9 to 1) (6.6 to 7.4)
Suspension upper link - impulse pick-up cable plate securing screw (1)	9 to 10 (0.9 to 1) (6.6 to 7.4)

(1) Vehicles equipped with (ABS) MARK II wheel antilock braking system.



## FRONT SUSPENSION

# TROUBLESHOOTING

Fault	Cause	Remedy
Shock, vibration or shimmy	<ul style="list-style-type: none"> <li>- Shocks on steering wheel from road feedback. May be caused by excessive pinion rack backlash or steering components play.</li> <li>- Steering wheel oscillation may be due to steering linkage play or pinion rack backlash, or front wheel vibration.</li> <li>- Shimmy is a high frequency oscillation transmitted to steering wheel and often occurs at particular vehicle speeds.</li> </ul>	<ul style="list-style-type: none"> <li>Inflate correct tyre</li> <li>Balance or repair</li> <li>Replace or tighten</li> <li>Replace ball joint</li> <li>Adjust backlash</li> <li>Replace bushings</li> <li>Check and replace as necessary</li> <li>Tighten screws</li> <li>Tighten or replace</li> </ul>
Car wanders	<ul style="list-style-type: none"> <li>- This fault is detected with the car on the move on a level road by taking hands off the steering wheel. See also: Group 25 - Troubleshooting.</li> </ul>	<ul style="list-style-type: none"> <li>Replace tyres</li> <li>Inflate to correct pressure and/or tighten</li> <li>Replace tyre with shallower tread</li> <li>Adjust trim</li> <li>Adjust</li> <li>Check and repair</li> <li>Replace worn parts</li> <li>Replace defective parts</li> </ul>

## FRONT SUSPENSION

Fault	Cause	Remedy
Excessive steering wheel play	<ul style="list-style-type: none"> <li>• Incorrect pinion rack backlash</li> <li>• Worn steering components</li> <li>• Loose steering box screws</li> </ul>	<p>Adjust</p> <p>Replace worn parts</p> <p>Tighten</p>
Noise	<ul style="list-style-type: none"> <li>• Incorrect tyre pressure</li> <li>• Damaged and worn ball joints or steering components. Insufficient lubrication</li> <li>• Loose steering linkage or suspension fasteners</li> <li>• Defective shock absorbers</li> <li>• Inefficient wheel bearings</li> <li>• Inefficient suspension bushings</li> <li>• Damaged torsion bars</li> <li>• Loose shock absorber nut</li> </ul>	<p>Inflate to correct pressure</p> <p>Replace or lubricate</p> <p>Tighten</p> <p>Replace</p> <p>Replace</p> <p>Replace</p> <p>Replace</p> <p>Tighten</p>
Tyres squeal on corners	<ul style="list-style-type: none"> <li>• Incorrect tyre pressure</li> <li>• Incorrect wheel geometry</li> <li>• Incorrect driving</li> </ul>	<p>Inflate to correct pressure</p> <p>Adjust</p> <p>Avoid incorrect driving</p>
Uneven tyre wear	- See Group 28 - Wheels and tyres.	
Steering wheel binding	<ul style="list-style-type: none"> <li>• Incorrect tyre pressure</li> <li>• Worn tyres</li> <li>• Incorrect pinion rack backlash</li> </ul> <p>- After these preliminary operations, if fault persists check and operate as follows: Raise vehicle front end using a jack and apply stands. Detach steering linkage from steering knuckle and move steering wheel.</p> <p>a) If steering wheel movement is light, check steering linkage or suspension. b) If steering wheel binds, check steering box or steering column.</p> <ul style="list-style-type: none"> <li>• Incorrect steering box lubrication and/or contaminated lubricant</li> </ul>	<p>Inflate to correct pressure</p> <p>Replace</p> <p>Adjust</p> <p>Lubricate or change lubricant</p>

## FRONT SUSPENSION







Fault	Cause	Remedy
	<ul style="list-style-type: none"><li data-bbox="565 300 932 380">• Incorrect steering linkage lubrication, contaminated grease or abnormal steering wear</li><li data-bbox="565 415 829 443">• Worn or seized ball joint</li><li data-bbox="565 474 829 501">• Distorted steering linkage</li><li data-bbox="565 533 829 560">• Incorrect wheel geometry</li></ul>	Lubricate correctly, change grease or replace worn parts  Replace  Replace  Adjust

# FRONT SUSPENSION

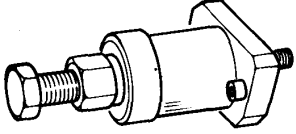
## SPECIAL TOOLS

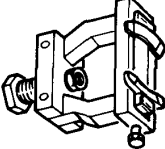
Part. no.	Description	Page
A.2.0069	Support, torsion bar load/unload (use with A.2.0265)	21-4/1 21-8/1
A.2.0265	Loader/unloader, torsion bars (use with A.2.0069)	21-4/1 21-8/1
A.3.0156	Puller, steering knuckle upper pins	21-5
A.3.0328	Installer, front hub outer bearing cup	21-7
A.3.0329	Installer, front hub inner bearing cup	21-7
A.3.0367	Bolster, upper link anti-vibration bushing removal/installation (use with A.3.0368)	21-15
A.3.0368	Remover/replacer, upper link anti-vibration bushing (use with A.3.0367)	21-15
A.3.0372	Remover/replacer, lower link (use with A.3.0373)	21-11 21-12 21-13
A.3.0373	Toothed washer, lower link removal/installation (use with A.3.0372)	21-11 21-13

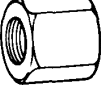
## FRONT SUSPENSION

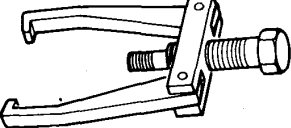
Part. no.	Description	Page
A.3.0374	Remover, torsion bars 	21-10 21-11
A.3.0374/0001	Forcing screw, torsion bar removal 	21-10
A.3.0377	Puller, upper and lower ball joints, steering knuckle 	21-4/1 21-5 21-14 ]
A.3.0441	Ring, lower link ball joint removal (use with A.3.0576 and A.3.0575) 	21-12
A.3.0442	Ring, lower link ball joint installation (use with A.3.0576 and A.3.0562) 	21-12
A.3.0562	Centralizer, front suspension link ball pin installation (use with A.3.0576 and A.3.0442) 	21-12
A.3.0575	Centralizer, front suspension link ball pin removal (use with A.3.0576 and A.3.0441) 	21-12
A.3.0576	Remover/replacer, front suspension link ball pin (use with A.3.0575; A.3.0441; A.3.0442; A.3.0562) 	21-12