

STEERING

GROUP 23

CONTENTS

DESCRIPTION	23-2	Power steering lines	23-20
STEERING WHEEL AND COLUMN	23-3	Power steering fluid reservoir	23-21
Steering wheel	23-3	Steering pump drive belt	23-21
Antitheft - ignition switch	23-3	MECHANICAL STEERING	23-23
Steering column with steering wheel		Mechanical steering unit	23-23
adjustable for height and read	23-4	INSPECTION SPECIFICATIONS	23-28
Steering column with steering wheel		General requirements	23-28
adjustable for height	23-8	Checks and adjustments	23-29
POWER STEERING	23-11	Tightening torques	23-30
Description	23-12	TROUBLESHOOTING	23-31
Power steering unit	23-13	Power steering	23-31
Steering pump	23-17	Mechanical steering	23-32
[Hydraulic system filling and bleeding	23-20	SPECIAL TOOLS	23-33

STEERING

DESCRIPTION

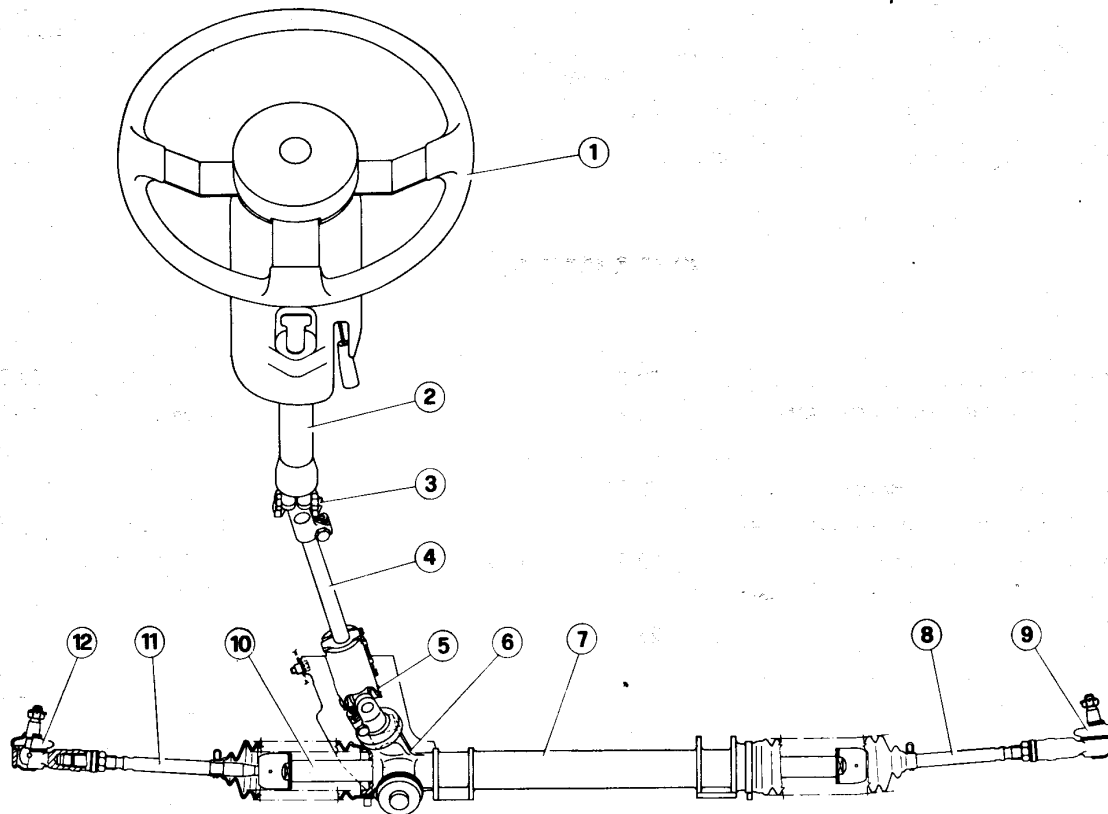

- 1 Steering wheel
- 2 Steering column support and upper column
- 3 Upper U-joint
- 4 Lower column
- 5 Lower U-joint
- 6 Steering unit

- 7 Rack housing
- 8 Right tie rod
- 9 Ball joint
- 10 Rack
- 11 Left tie rod
- 12 Ball joint

Steering is rack and pinion, mechanical or power assisted depending on car model.

Tie rods are directly connected to rack. To afford the driver increased protection in the event of frontal impact steering un-

it is offset rearward.

For the same reason, steering column is split and incorporates two universal joints. Two types of steering columns are installed depending on car model.

On **Alfa 90** and **Alfa 75**

steering column support is secured to body through sliding pads permitting steering wheel adjustment for height and reach. On other models, steering columns support is hinged to chassis, permitting steering wheel adjustment for height.

STEERING WHEEL AND COLUMN

STEERING WHEEL

REMOVAL

1. Disconnect battery ground cable.
2. Remove hub cover ① by finger pressure.

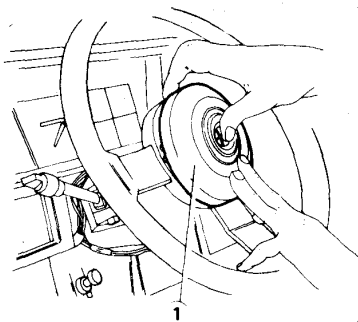

1 Hub cover

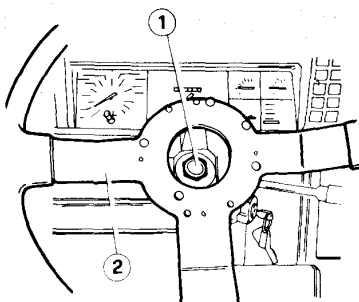

1 Steering wheel nut
2 Steering wheel

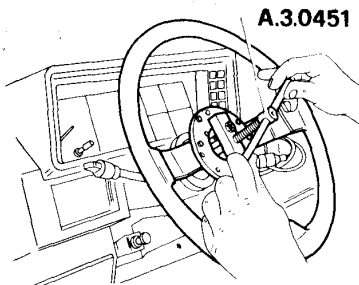

A.3.0451

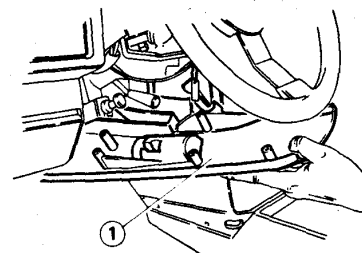

1 Lower half cowl

2. Disconnect antitheft-ignition switch lead ②.
3. Using a punch, back off capscrew ④ and remove antitheft-ignition switch ②.
4. Install by reversing the removal sequence.

CAUTION:

Ignition switch ② capscrew must be tightened until hex. head is wrenched off.

3. Back off 4 horn capscrews ①, disconnect lead ② and remove pushbutton.

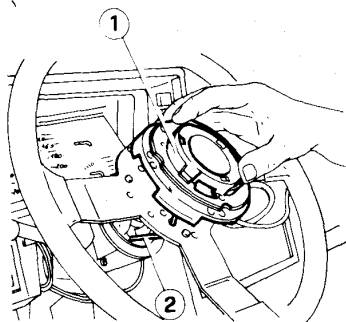

1 Horn pushbutton
2 Horn ground lead

INSTALLATION

Install steering wheel on car by reversing the removal sequence and adhering to the instructions given below.

- Align wheels.
- Position steering wheel on steering column, centralize spokes and tighten nut to the specified torque (see Inspection Specifications - Tightening Torques).
- Rotate steering wheel in both directions and check for binding.
- Check horn operation.

ANTITHEFT - IGNITION SWITCH

REMOVAL AND INSTALLATION

1. Back off capscrews and remove upper and lower half cowls ① of steering column.

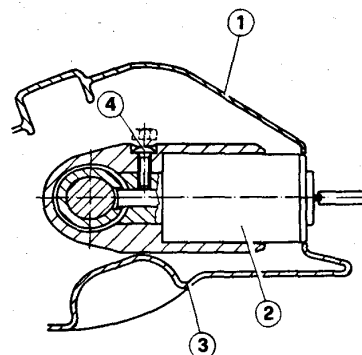

1 Upper half cowl
2 Antitheft-ignition switch
3 Lower half cowl
4 Ignition switch capscrew

STEERING

STEERING COLUMN WITH STEERING WHEEL ADJUSTABLE FOR HEIGHT AND REACH

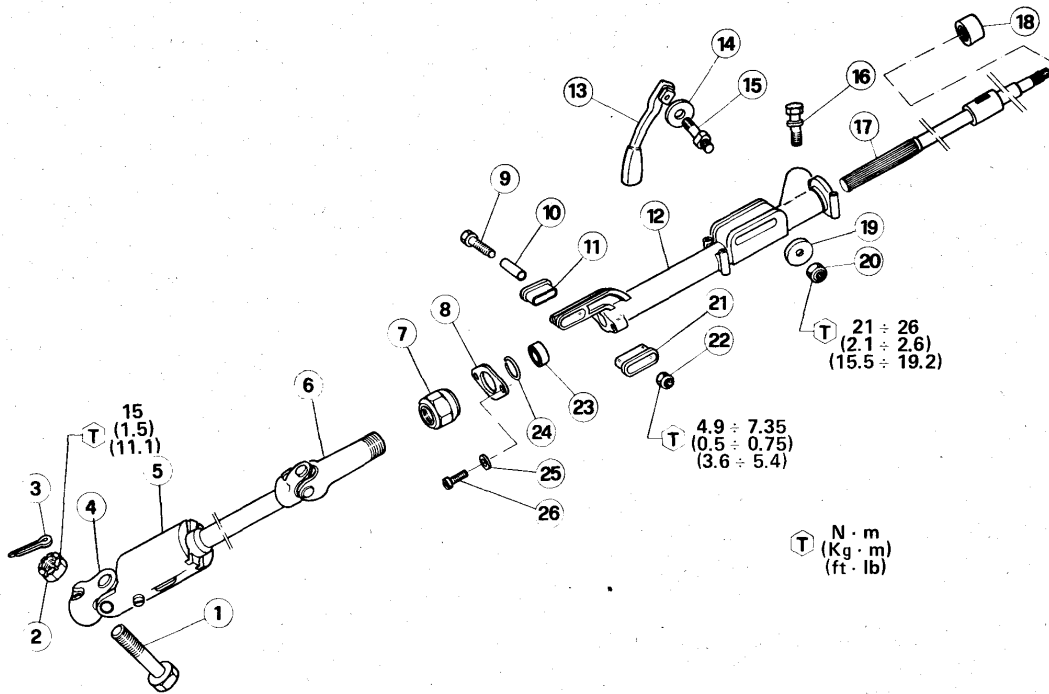

T N · m
(Kg · m)
(ft · lb)

- | | | |
|--------------------------------|-----------------------------------|---------------------|
| 1 Steering box pinion capscrew | 10 Bushing | 19 Washer |
| 2 Nut | 11 Sliding pad seal | 20 Nut |
| 3 Cotter pin | 12 Steering column support | 21 Sliding pad seal |
| 4 Lower U-joint | 13 Steering wheel adjusting lever | 22 Nut |
| 5 Lower steering column | 14 Washer | 23 Ball bearing |
| 6 Upper U-joint | 15 Pin | 24 Retaining ring |
| 7 Sliding sleeve nut | 16 Anti-theft capscrew | 25 Washer |
| 8 Retaining plate | 17 Upper steering column | 26 Capscrew |
| 9 Capscrew | 18 Needle roller bushing | |

REMOVAL

1. Remove steering wheel (see Steering Wheel - Removal).
2. Back off 6 upper and lower half cowl capscrews and remove cowl.
3. Unlock steering column through the lever, lower and remove upper half cowl.
4. Disconnect connectors (3), back off capscrews (1) and remove turn signal switch unit (2).

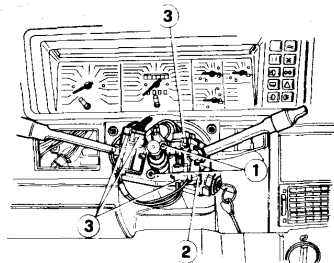

- 1 Capscrews
- 2 Turn signal switch unit
- 3 Turn signal switch unit connectors

5. Cars provided with manual cold start device.

Disconnect connections (4) from cold start device control, remove control by releasing spring (2) and disconnect from support (3) withdrawing cable (5) from associated slot.

STEERING

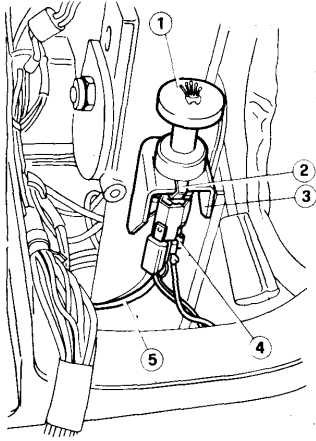

- 1 Cold start device control
- 2 Retaining spring
- 3 Cold start device control support
- 4 Cold start device control on indicator connection
- 5 Cold start device control cable

6. Back off nut ①, remove lever ② with associated washers and disconnect steering column from bracket ③.
7. Remove bolt ⑤ and disconnect steering column ④ from bracket ⑥ retrieving spacer.

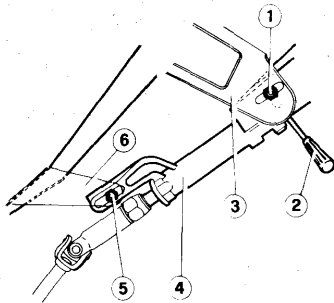

- 1 Lever retaining nut
- 2 Steering wheel adjusting lever
- 3 Upper bracket
- 4 Steering column
- 5 Steering column to lower bracket bolt
- 6 Lower bracket

8. Slacken nut ④ and take off steering column ① disconnecting from intermediate shaft sleeve ③.

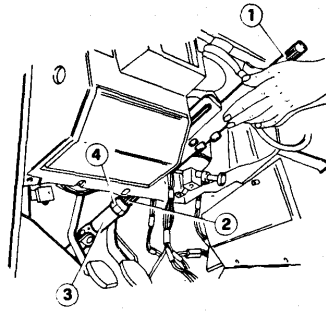

- 1 Steering column
- 2 Steering column spline
- 3 Sleeve
- 4 Nut

9. Remove cotter pin ①, back off bolt ② and disconnect intermediate shaft ③ with U-joint and sleeve from steering unit ④.

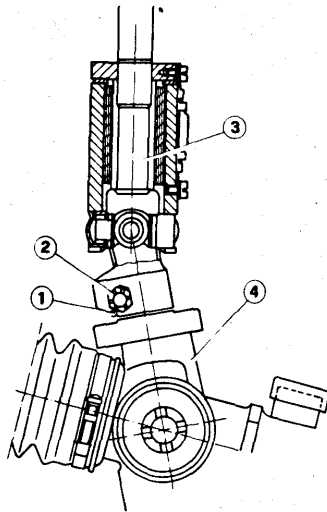

- 1 Cotter pin
- 2 Bolt
- 3 Intermediate shaft
- 4 Steering unit

10. Back off 3 capscrews ② and take off intermediate shaft ① with boot ③ and retaining plate ④.

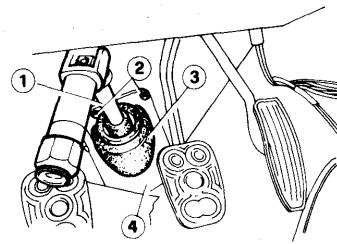

- 1 Intermediate shaft
- 2 Capscrews
- 3 Boot
- 4 Retaining plate

DISASSEMBLY

1. Clamp steering column support ① with upper steering column ③ in a vice provided with jaw liners.
2. Using hammer and punch, back off capscrew ② securing anti-theft to steering column support.

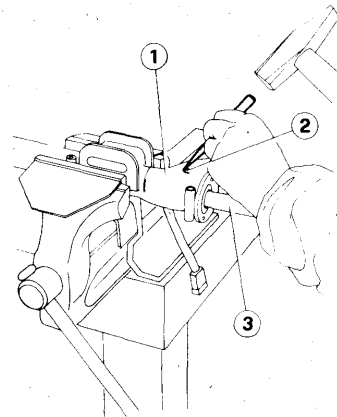

- 1 Steering column support
- 2 Anti-theft capscrew
- 3 Upper steering column

3. Disconnect lead ends from connector and mark relative position.
4. Take off anti-theft ① without damaging leads ②.

STEERING

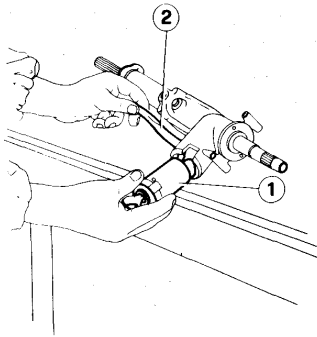

- 1 Anti-theft
- 2 Leads

5. Back off and remove lower bearing plate capscrews (1).

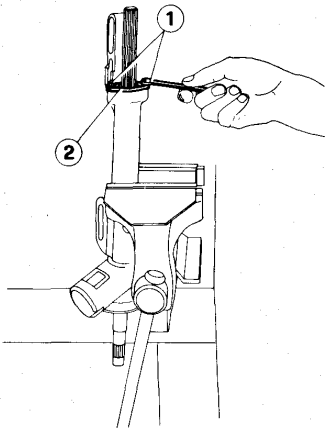

- 1 Capscrews
- 2 Plate

6. Remove lower bearing retaining ring.

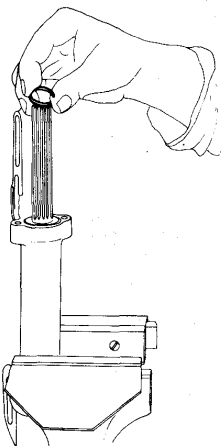

7. Using a plastic mallet, tap lower end of upper steering column (1).

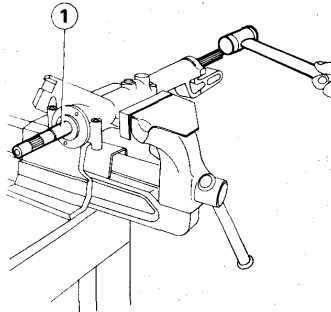

- 1 Upper steering column

8. Take off upper steering column with needle roller bushing (1) from steering column support (2) and retrieve bearing (3).

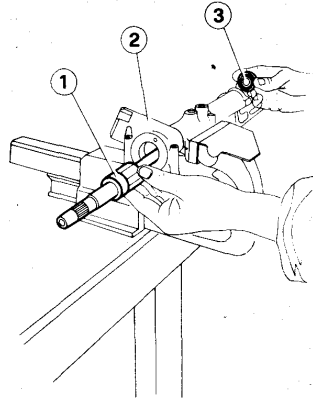

- 1 Needle roller bushing
- 2 Steering column support
- 3 Ball bearing

9. Take off needle roller bushing from steering column.

INSPECTION

Clean all parts.

1. Check needle roller bushing and ball bearing for damage or malfunction; replace as necessary.
2. Check upper steering column ensuring that bearing and needle roller bushing working surfaces are not scored. Check splines for damage or undue wear. Also check anti-theft pin recess.

ASSEMBLY

1. Lubricate lower ball bearing using the recommended grease (AGIP F1 Grease 33 FD or IP Autogrease FD).
2. Insert steering column (2) in support (3) and press ball bearing (1) home in steering column bottom.

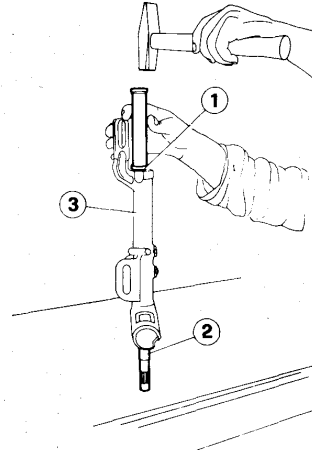

- 1 Ball bearing
- 2 Steering column
- 3 Steering column support

3. Install bearing retaining ring ensuring that it is pressed fully home.

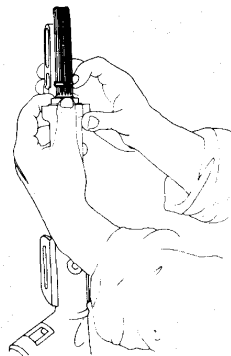

STEERING

4. Place lower bearing retaining plate in position and lock through associated capscrews.

5. Lubricate needle roller bushing seat on steering column support using the recommended grease (SPCA Spagraph or ISECO Ergon Rubber Grease n. 3).

6. Insert upper needle roller bushing ① fully home between steering column and support and check that steering column rotates without binding or excessive clearance.

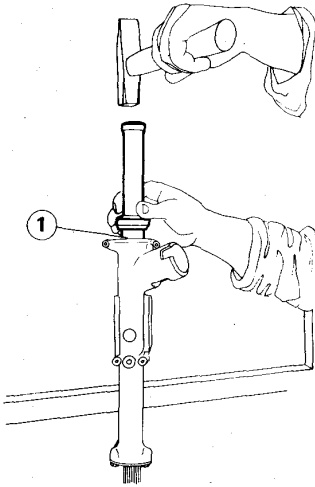

1 Needle roller bushing

7. Insert antitheft device ① feeding leads ③ through associated slot ②.

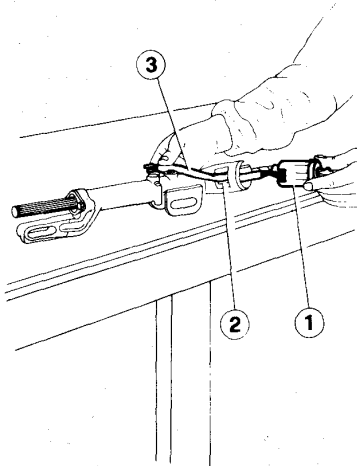

1 Antitheft device
2 Slot
3 Leads

8. Centralize antitheft device, insert cap-screw ① available as spare and tighten until head is wrenched off.

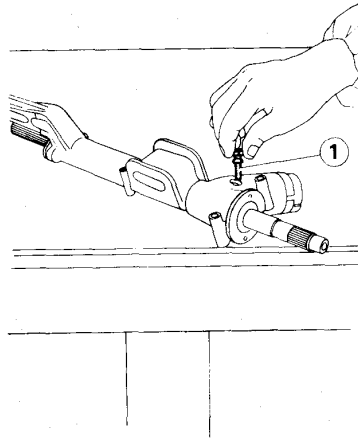

1 Locking capscrew

9. Install lead connector aligning reference marks previously applied.

INSTALLATION

CAUTION:

Sliding sleeve nut connecting steering column to intermediate shaft spline must be tightened to obtain 34 to 44 N (3.5 to 4.5 kg) (7.7 to 9.9 lb) end sliding load on spline.

Install by reversing the removal sequence and adhering to the instructions given below.

- Correctly position turn signal switch unit on steering column.
- Apply the recommended grease (ISECO Molykote Pasta G) on steering column support flanges and on steering column and sliding sleeve splines.
- Adhere to the following tightening torques.

Ⓜ: Tightening torques

Steering column/lower support bolt

4.9 to 7.35 N·m
(0.5 to 0.75 kg·m)
(3.6 to 5.4 ft·lb)

Steering column/upper support nut (with steering wheel lever locked)

21 to 26 N·m
(2.2 to 2.7 kg·m)
(15.5 to 19.2 ft·lb)

Intermediate shaft/steering unit pinion U-joint bolt

15 N·m
(1.5 kg·m)
(11.1 ft·lb)

Tighten to permit cotter pin insertion.

STEERING

STEERING COLUMN WITH STEERING WHEEL ADJUSTABLE FOR HEIGHT

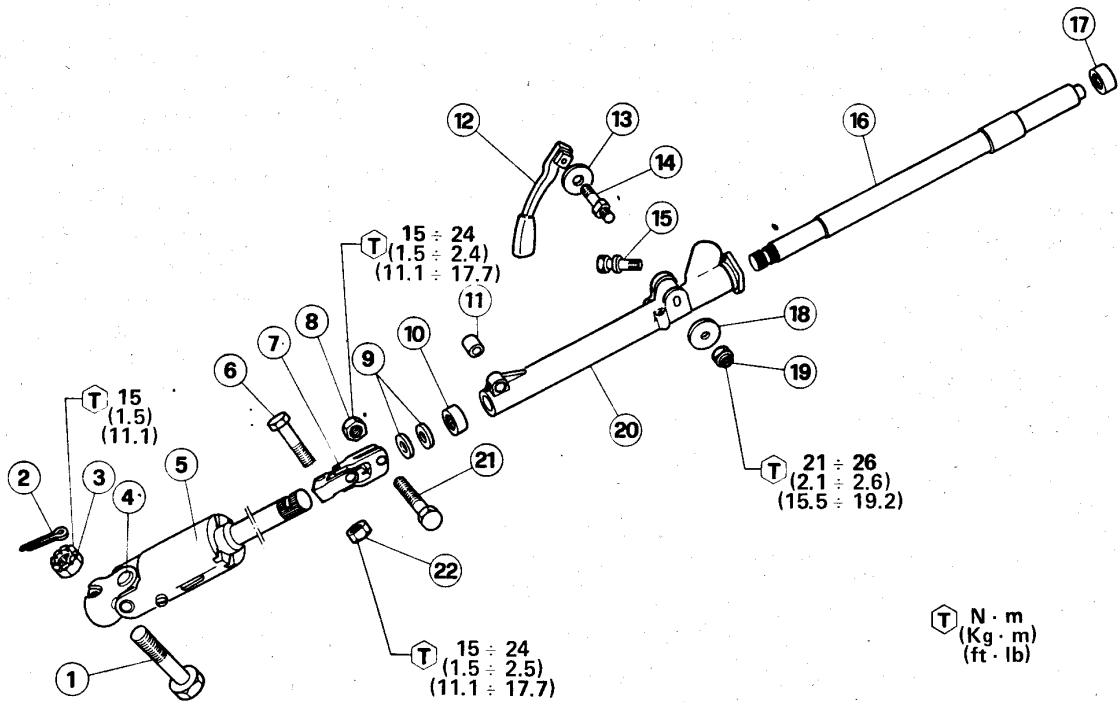

- 1 Steering unit pinion capscrew
- 2 Cotter pin
- 3 Nut
- 4 Lower U-joint
- 5 Lower steering column
- 6 Capscrew
- 7 Upper U-joint
- 8 Nut

- 9 Washers
- 10 Lower needle roller bushing
- 11 Antivibration bushing
- 12 Steering wheel adjusting lever
- 13 Washer
- 14 Pin
- 15 Antitheft capscrew

- 16 Upper steering column
- 17 Upper needle roller bushing
- 18 Washer
- 19 Nut
- 20 Steering column support
- 21 Capscrew
- 22 Nut

REMOVAL

1. Remove steering wheel (see: Steering Wheel - Removal).
2. Back off lower half cowl capscrews ① and remove cowl ②.

3. Cut lead clip and disconnect turn signal switch unit wiring harness.
4. Remove turn signal switch unit ① by backing off 2 bolts ②.

5. Disconnect antitheft wiring harness.
6. Slacken and remove bolt ① securing U-joint ③ to lower steering column ②.

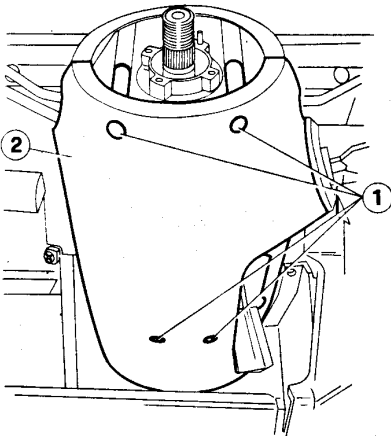

- 1 Capscrews
- 2 Lower half cowl

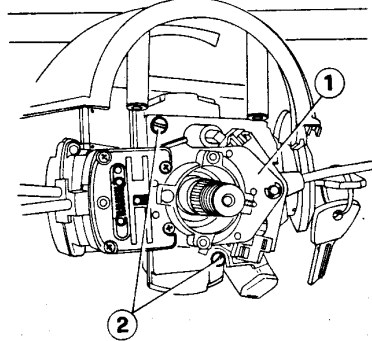

- 1 Turn signal switch unit
- 2 Bolts

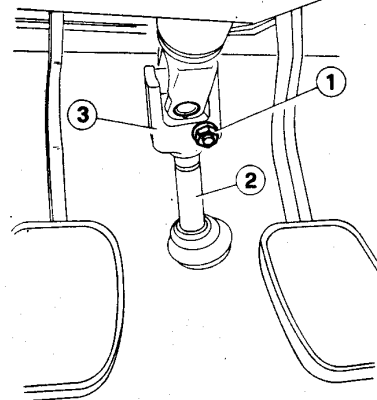

- 1 Bolt
- 2 Lower steering column
- 3 U-joint

STEERING

7. Back off and remove bolt ④ securing steering column support ③ to body.
8. Remove adjusting lever pin after backing off associated nut ①.

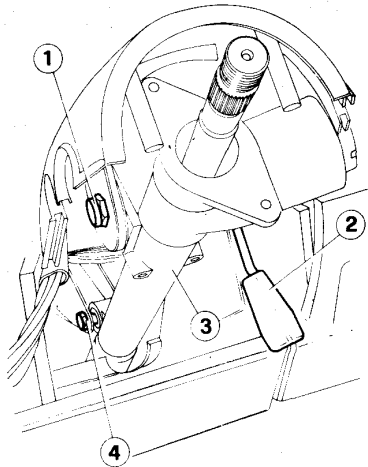

- 1 Nut
- 2 Adjusting lever
- 3 Steering column support
- 4 Bolt

9. Remove steering column and retrieve upper half cowl.

DISASSEMBLY

1. Clamp steering column support ① with attached upper steering column in a vice provided with protective jaw liners and back off upper U-joint ③ securing bolt ②.

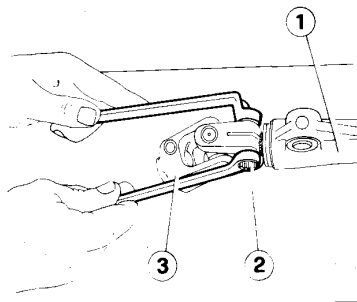

- 1 Steering column support
- 2 Bolt
- 3 U-joint

2. Take off U-joint ① and 2 washers ② from upper steering column lower end.

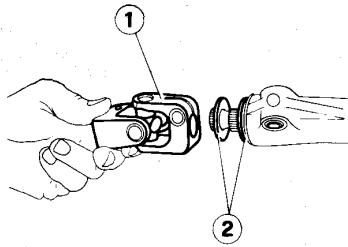

- 1 U-joint
- 2 Washers

3. Using hammer and punch, back off capscrew ① securing antitheft to steering column support ②.

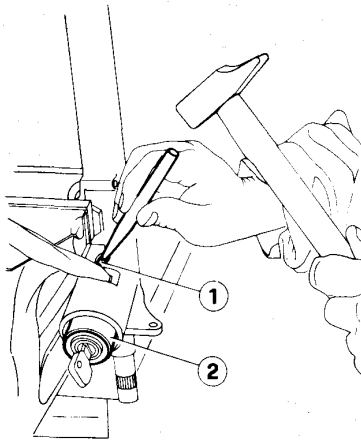

- 1 Locking screw
- 2 Antitheft device

4. Disconnect lead ends from connector and mark relative position.
5. Take off antitheft ① without damaging leads ②.

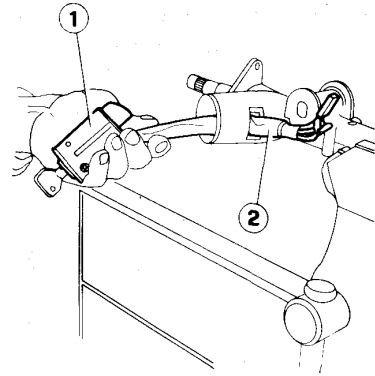

- 1 Antitheft device
- 2 Leads

6. With unit clamped in vice and using a plastic mallet, tap on steering column lower end ② to remove it from support ① with associated upper needle roller bushing.

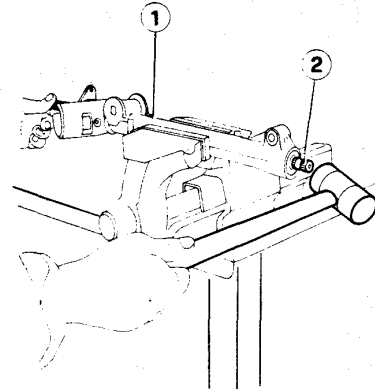

- 1 Steering column support
- 2 Steering column

7. Remove upper needle roller bushing from steering column and take off lower needle roller bushing from steering column support.

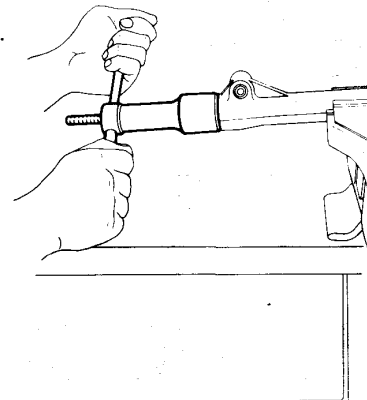

STEERING

8. Remove antivibration bushing from seat in steering column support bottom.

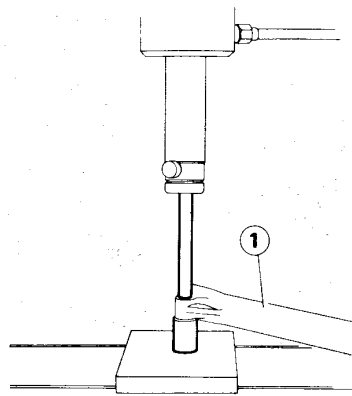
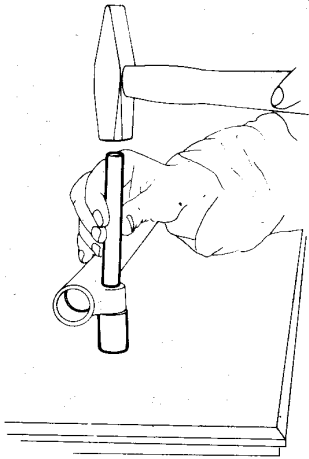

1 Steering column support

2. Lubricate needle roller bushing seat on steering column support using the recommended grease (SPCA Spagraph or ISECO Ergon Rubber Grease No. 3).
3. Using tool A.3.0346, insert lower needle roller bushing fully home in seat on steering column support.

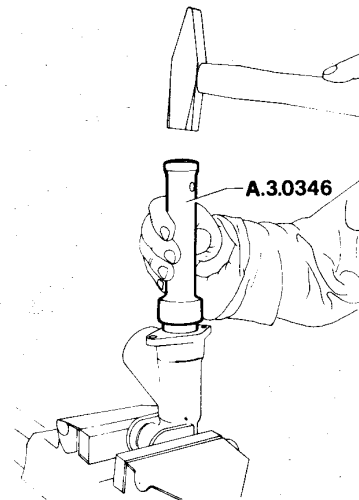

6. Insert antitheft device ① feeding leads ② through associated slot ③.

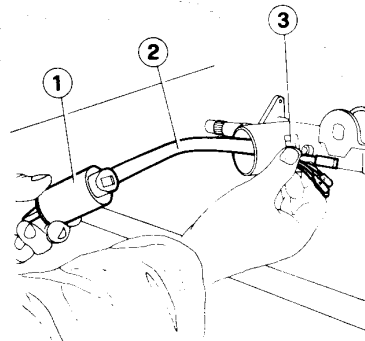

- 1 Antitheft device
2 Slot
3 Leads

7. Centralize antitheft device, insert cap-screw ① available as spare and tighten until head is wrenched off.

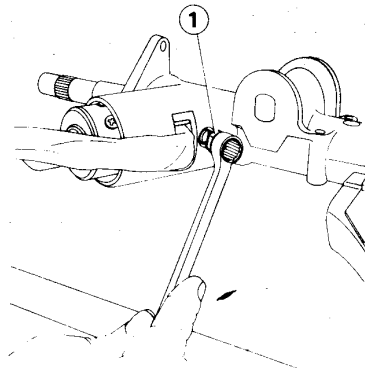

1 Locking cap-screw

INSPECTION

Clean all parts.

1. Check steering column needle roller bushings for damage or malfunction; replace as necessary.
2. Check that U-joint is not damaged.
3. Check upper steering column ensuring that bearing and needle roller bushing working surfaces are not scored. Check splines for damage or undue wear. Also check antitheft pin recess.
4. Check antitheft and steering column support for damage; replace as necessary.

ASSEMBLY

1. At the press, insert ball joint in seat on steering column support bottom.

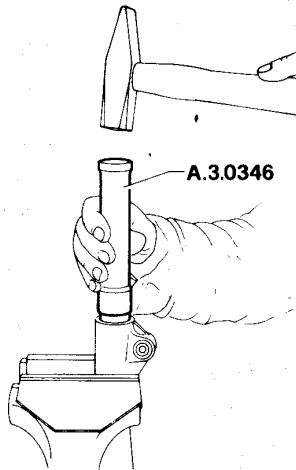

4. Introduce steering column from steering column support top and insert in lower bushing.
5. Using tool A.3.0346, insert upper needle roller bushing in seat on steering column support and check that steering column rotates freely without binding or excessive clearance.

STEERING

8. Install lead connector aligning reference marks previously applied.
9. Install U-joint with associated washers on steering column lower end.

INSTALLATION

Install by reversing the removal sequence and following the instructions given below.

1. Place front wheels in straight ahead driving position and install upper half cowl, steering column and steering wheel with spokes horizontal.
2. Secure steering column support to body and U-joint to lower steering column installing bolt without tightening.
3. Take off steering wheel.
4. Install turn signal switch unit, lower half cowl and steering wheel (see steering Wheel-Installation).

5. Tighten U-joint/lower steering column bolt ensuring freedom from binding or excessive clearance between steering wheel ① and half cowl ②.

6. Install horn pushbutton, hub, and connect battery lead.
7. Check turn signal switch and horn operation.

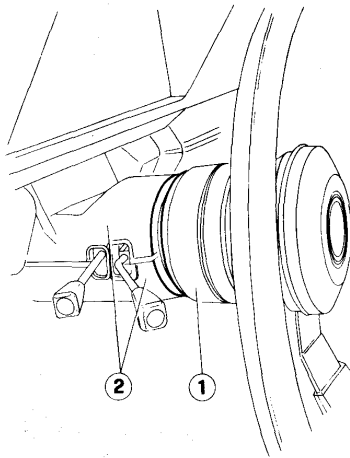

- 1 Steering wheel
- 2 Cowl

POWER STEERING

- 1 Reservoir
- 2 Hose
- 3 Pipe
- 4 Pump/steering unit pipe
- 5 Reservoir/pump pipe

- 6 Steering pump pulley
 - 7 Steering pump
 - 8 Equalizer air pipe
 - 9 Steering unit
- Direction of fluid flow

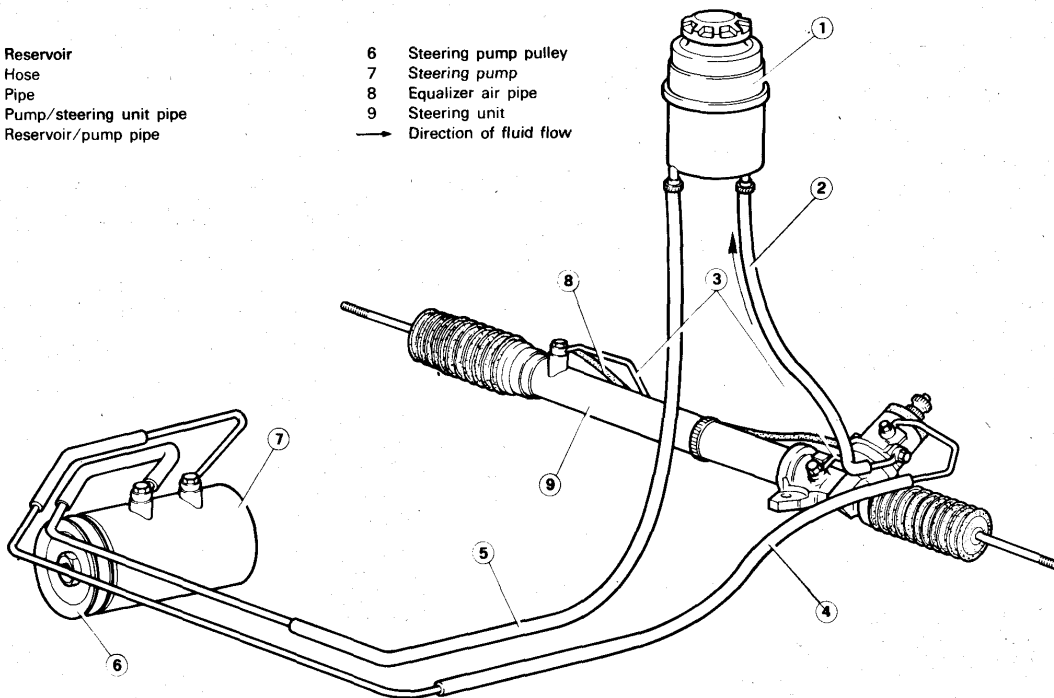

STEERING

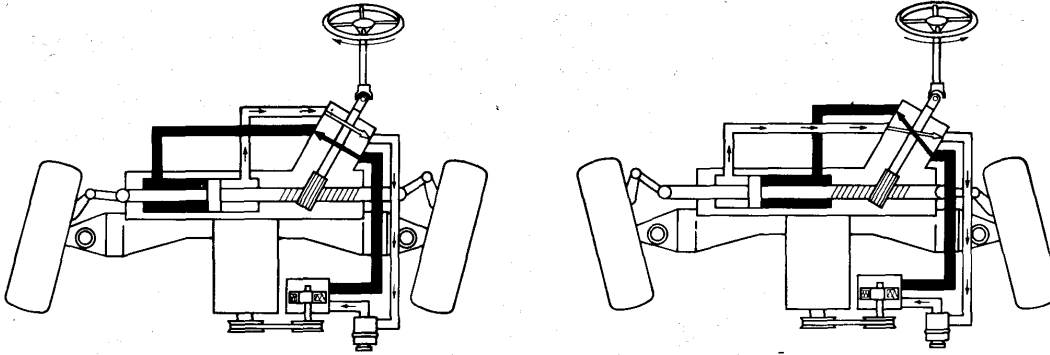

DESCRIPTION

- Power steering consists of:

- Reservoir ①
- Pump ⑦
- Hydraulic piping
- Steering unit ⑨

- The reservoir provided with filter feeds circuit and eliminates impurities.
- The V-belt crankshaft-driven pump is a swash plate and radial piston unit supplying fluid under pressure

to hydraulic control valve integral with steering unit.

The pump is of the energy-saving type in that, even in changing operating conditions, it draws only the amount of fluid necessary for power steering operation.

- A pump-mounted relief valve maintains delivery pressure at a safe level.
- On steering wheel rotation, pinion on the end of steering column moves the rack, tie rods and steering knuck-

les to steer the road wheels.

Simultaneously, hydraulic control valve is activated to supply fluid under pressure to actuating cylinder. The resulting boost on steering wheel rotation reduces driver's effort.

- Thus, steering is a mechanical unit with assistance in the form of hydraulic power boost. Consequently, in case of fluid supply failure the unit operates as a normal mechanical non-assisted device.

STEERING

POWER STEERING UNIT

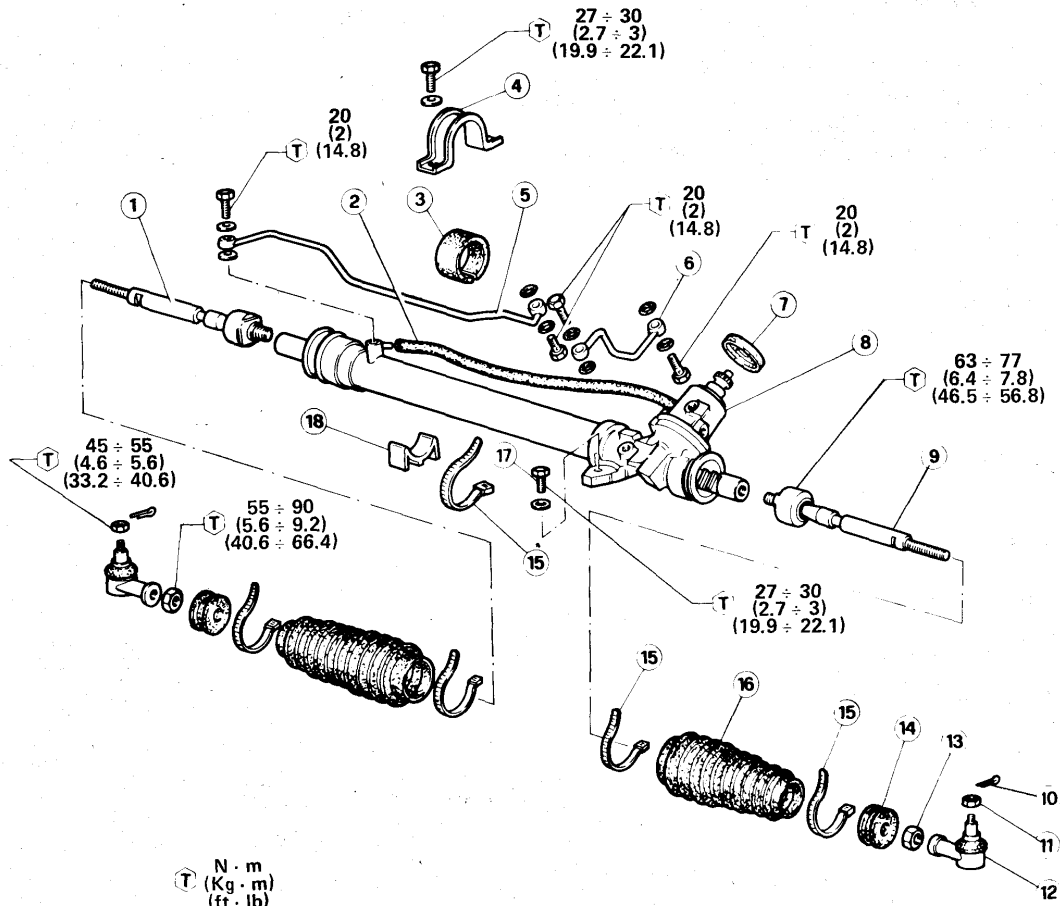

- | | |
|--------------------------------|---------------------------|
| 1 Right tie rod | 10 Cotter pin |
| 2 Equalizer air pipe | 11 Nut |
| 3 Cushion support | 12 Ball joint |
| 4 Bracket | 13 Nut |
| 5 Pipe | 14 Rubber ring |
| 6 Pipe | 15 Clip |
| 7 Dust excluder | 16 Bellows |
| 8 Power steering control valve | 17 Steering unit capscrew |
| 9 Left tie rod | 18 Support |

STEERING

REMOVAL

1. Place car on a platform lift and restrain rear wheels using suitable chocks.

WARNING:

If the engine is warm proceed with caution.

2. Disconnect battery.
3. Back off reservoir cap ① draw fluid using a syringe and replace cap.

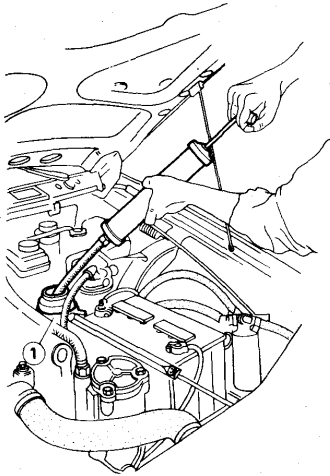

1 Power steering fluid reservoir

4. Slacken front wheel nuts. Raise car front end and prop with support stands. Remove front wheels.
5. Raise car on platform lift and disconnect two fittings ① from steering unit ② from underside of body.

CAUTION:

After removal, put back the two fitting capscrews on steering unit.

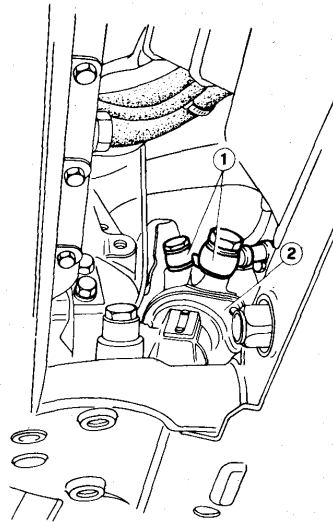

1 Fluid delivery/return pipe fitting
2 Power steering unit

6. Take off cotter pin ①, back off and remove bolt ② and take off sleeve ④ from steering pinion.

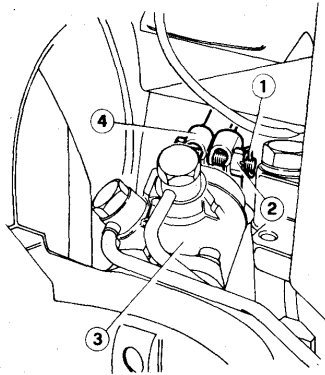

1 Cotter pin
2 Bolt
3 Power steering unit
4 U-joint sleeve

7. Remove ball joint pins from steering knuckles.

- a. Take off nut cotter pin.
- b. Back off and remove unit.
- c. Using puller A.3.0156, take off ball joint pins.

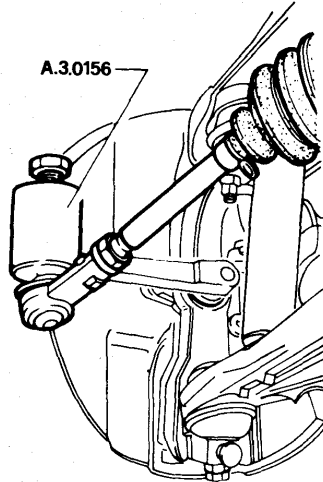

8. Back off 4 capscrews ① and remove support ③ and bracket ② from right side of car.

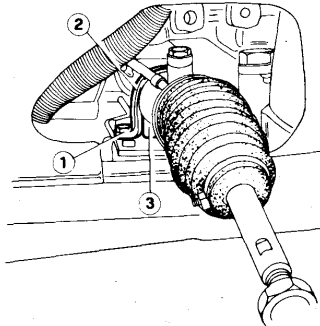

1 Steering unit to body capscrew
2 Bracket
3 Support

9. Suitably turn steering unit ① with attached tie rods and take off from left side of car.

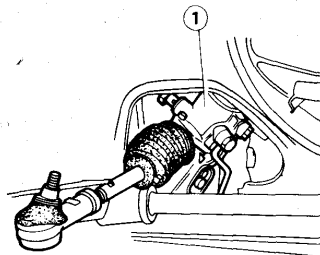

1 Power steering unit

STEERING

DISASSEMBLY

CAUTION:

Measure ball joint ③ protrusion from tie rods ① to be restored on assembly.

1. Slacken locknut ②, back off and remove ball joint from tie rod ①.

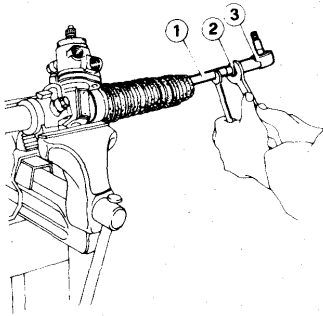

- 1 Tie rod
- 2 Locknut
- 3 Ball joint

2. If necessary, back off and remove 4 fittings ① from power steering unit.
3. If necessary, remove pipe ③ from associated fittings ④.

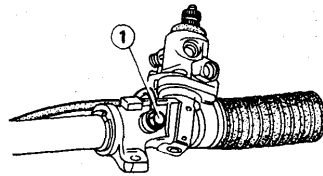
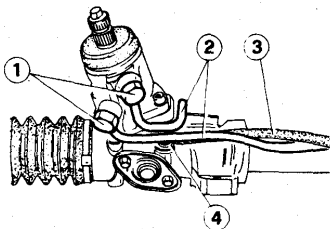
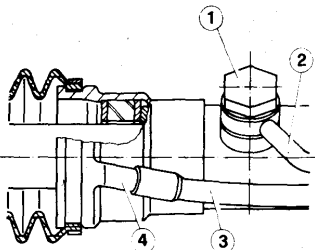

- 1 Pipe fitting
- 2 Pipes
- 3 Equalizer air pipe
- 4 Equalizer air pipe fitting

4. Cut clips ① and remove bellows ④ on both sides, along with rubber rings ③ on tie rod ②.

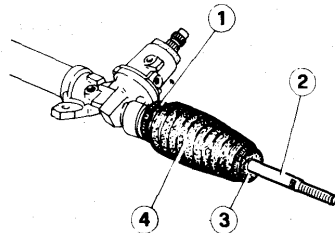

- 1 Plastic clip
- 2 Tie rod
- 3 Rubber ring
- 4 Bellows

5. Remove staked metal on ball joints ①, back off and remove joints from rack ②.

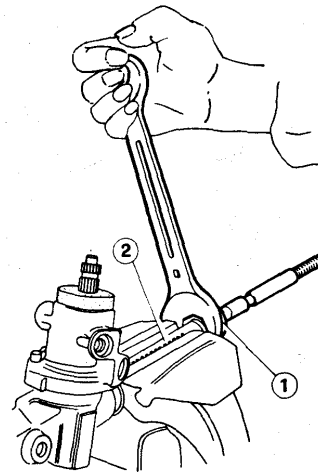
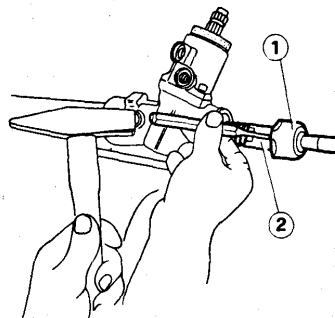

- 1 Ball joint
- 2 Rack

INSPECTION

Clean and visually inspect all parts carefully.

- Check that tie rod ball joints are not damaged or worn, and that they rotate freely without binding or excessive play.
- Check that tie rods are not damaged or distorted.
- Check rubber bellows, if cracked or scored replace without hesitation.

ASSEMBLY

Assemble by reversing the disassembly sequence and following the instructions given below:

- Tighten tie rods on rack to the specified torque.

Tightening torque

Tie rod ball joint

63 to 77 N·m
(6.4 to 7.9 kg·m)
(46.5 to 56.8 ft·lb)

- Stake tie rod ball joint.

STEERING

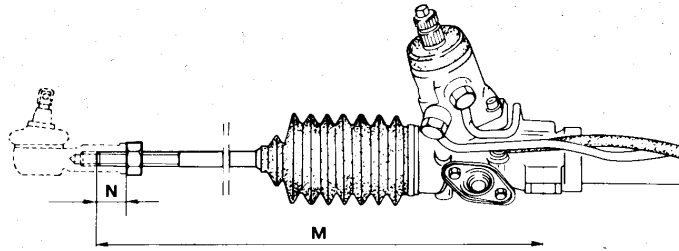
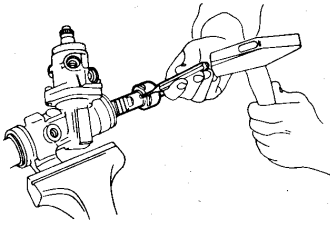

- c. Using plastic clips, secure bellows and pipes centrally on steering unit.
- d. Tighten pipe fitting to the specified torque.

T : Tightening torque

Pipe fitting to steering unit

20 N · m
(2 kg · m)
(14.8 ft · lb)

- e. Install locknut and ball joint on tie rods. Check that ball joint protrusion is as measured on disassembly; in case of replacement, restore specified fitted length.

Tie rod ball joint assembly data

N = 26 mm (1.02 in)

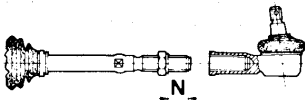

2. Suitably turn steering unit and position on vehicle from left side.
3. From right side, install cushion support and steering unit/cross member cap-screws from left to right and tighten to the specified torque.

T : Tightening torque

Steering box/cross member cap-screws

27 to 30 N · m
(2.7 to 3.0 kg · m)
(19.9 to 22.1 ft · lb)

4. With road wheels in straight-ahead driving position, check that steering wheel spokes are centralized and install intermediate shaft U-joint on steering pinion. Insert bolt in spline, tighten bolt and insert cotter pin.
5. Connect ball joint pins to steering knuckles from both car sides. Tighten nuts to the specified torque and insert another cotter pin.

T : Tightening torque

Ball joint/steering knuckle nut

45 to 55 N · m
(4.5 to 5.5 kg · m)
(33.2 to 40.6 ft · lb)

6. Install front wheels and tighten nuts to the specified torque (see: Group 28 - Inspection Specifications). Remove stands.
7. Raise car and connect fluid delivery/return pipes to power steering control valve and tighten to the specified torque.

T : Tightening torque

Fluid delivery pipe fitting

22 to 24 N · m
(2.2 to 2.4 kg · m)
(16.2 to 17.7 ft · lb)

Fluid return pipe fitting

38 to 43 N · m
(3.9 to 4.4 kg · m)
(28 to 31.7 ft · lb)

8. After installation check toe-out (see Group 00 - Wheel Alignment). Tighten tie rod ball joint locknut to the specified torque.

T : Tightening torque

Ball joint locknut

54 to 88 N · m
(5.5 to 9 kg · m)
(39.8 to 64.9 ft · lb)

9. Connect battery.
10. Fill power steering circuit with fluid and bleed the system.
 - a. Fill reservoir with the recommended fluid (AGIP F1 ATF DEXRON B 11297; IP DEXRON FLUID B 11297; quantity: 0.8 kg).
 - b. Start engine and while idling rotate steering wheel in both directions from lock to lock; this operation facilitates fluid circulation and drains any air in reservoir.
 - c. Top up reservoir with the recommended fluid to the correct level.

INSTALLATION

1. Position rack so that protrusion from steering unit is as specified.

Steering unit assembly data

M = 399.5 mm LHD (15.73 in)
M = 394 mm RHD (15.51 in)

STEERING

STEERING PUMP

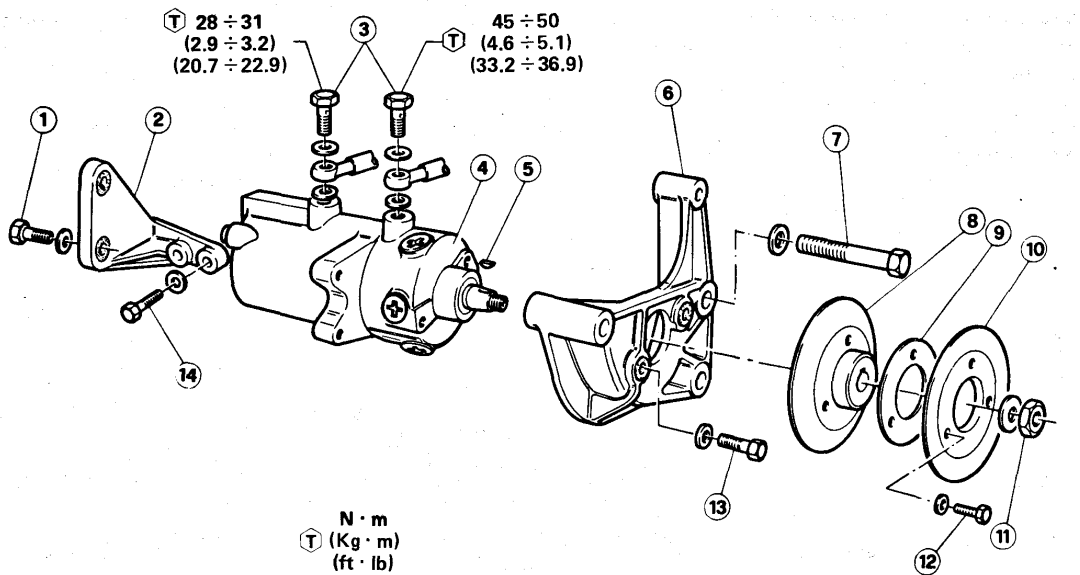

- | | | |
|----------------------|--|--|
| 1 Capscrew | 6 Pump front support | 11 Nut |
| 2 Pump rear support | 7 Front support to engine block capscrew | 12 Capscrew |
| 3 Fluid pipe fitting | 8 Inner half-pulley | 13 Capscrew |
| 4 Steering pump | 9 Spacer | 14 Rear support to engine block capscrew |
| 5 Key | 10 Outer half pulley | |

REPLACEMENT TURBODIESEL VERSION

Removal

- Place car on a platform lift and restrain rear wheels using suitable chocks.

CAUTION:

If the engine is warm proceed with caution.

- Disconnect battery.
- Back off reservoir cap and draw fluid using a syringe and replace cap.
- Disconnect pipe ① from separator ② and hose ④ from turbocharger inlet ③.
- Remove air cleaner cover ⑤, pipe ① and hose ④. Remove filter element.

- Back off bolts ⑥ and remove air cleaner housing from side wall.

- Disconnect alternator supply and indicator leads.
- Raise car and back off bolt ③ but do not remove. Lower car.

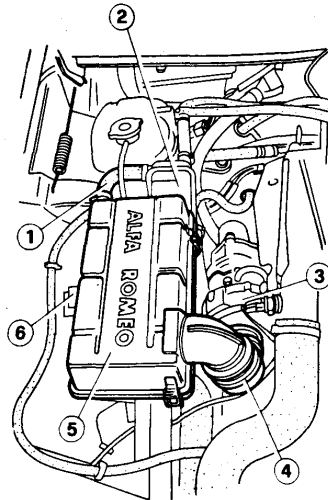

- | |
|---------------------------------|
| 1 PCV pipe |
| 2 Oil vapour separator |
| 3 Turbocharger |
| 4 Hose |
| 5 Air cleaner cover |
| 6 Air cleaner housing/body bolt |

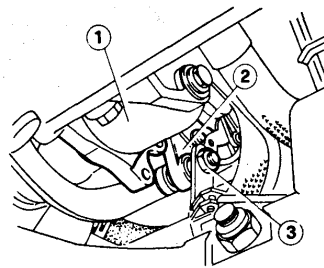

- | |
|-----------------|
| 1 Steering pump |
| 2 Alternator |
| 3 Bolt |

STEERING

9. Back off bolts ① and ④, slacken and remove alternator belt. Remove alternator ② and belt stretcher bracket ③ taking off lower bolt previously backed off.
10. Back off 3 capscrews ⑤ and remove outer half pulley ⑥ together with spacers and pump belt.

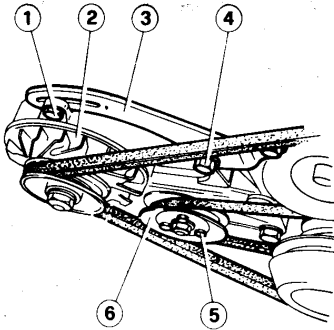

- 1 Bolt
2 Alternator
3 Belt stretcher bracket
4 Bolt
5 Capscrew
6 Outer half pulley

- 11 Back off and disconnect fittings ① from pump.

WARNING:
Tighten fittings capscrews on pump together with seals.

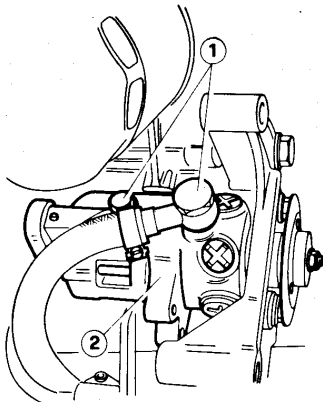

- 1 Fluid delivery/return pipe fittings
2 Steering pump

For the following paragraphs refer to exploded view on page 23-17.

12. Raise car and back off two rear support ② capscrews ⑭.
13. Lower car, back off two capscrews ⑦ and remove front support ⑥ together with steering pump ④ from engine block.
14. Provisionally install outer half pulley ⑩, previously removed, with associated spacers ⑨.
- Clamp pulley in a vice provided with protective liners and back off nut ⑪.

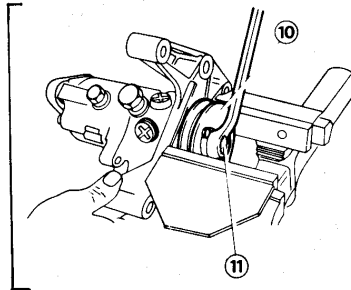

15. Take off pulley with pump shaft and retrieve key ⑤.

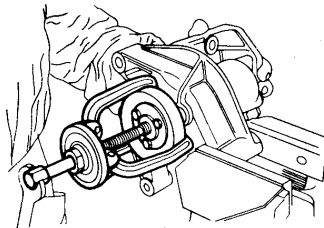

16. Back off two capscrews ⑬ and detach pump ④ from front support ⑥.
17. Back off two capscrews ① and detach pump ④ from rear support ②.

Installation

1. Install steering pump on supports and secure through associated capscrews.

WARNING:
Correctly position supports as pump must be placed with oil pipe fittings facing upward.

2. Install pulley on pump shaft and correctly position key; tighten nut.
3. Secure front support and steering pump to engine. Start 2 capscrews, raise car, tighten capscrews securing rear support to engine block. Lower car and tighten front support capscrews previously started.
4. Connect fluid delivery/return pipe fittings to pump (front and rear respectively) and tighten to the specified torque.

Tightening torque

Fluid delivery pipe fitting to steering pump fitting
28 to 31 N·m
(2.9 to 3.2 kg·m)³
(20.7 to 22.9 ft·lb)

Fluid return pipe fitting to steering pump fitting
45 to 50 N·m
(4.6 to 5.1 kg·m)
(33.2 to 36.9 ft·lb)

5. Install steering pump drive belt and associated half pulley with spacers correctly selected to obtain the right belt tension.

Check that yield "f" is 15 mm (0.6 in) for a force "P" of 147 ± 10 N (15 ± 1 kg; 33 ± 2 lb).

WARNING:
Increase spacer thickness to reduce belt tension and vice versa.

6. Install alternator with attached belt stretcher bracket and start but do not tighten lower bolt; the same bolt is used to secure outlet pipe support to steering pump.
7. Secure belt stretcher bracket to pump front support and engine cover and tighten capscrew and bolt.
8. Install alternator belt, adjust belt tension, and tighten upper bolt on belt stretcher bracket.

STEERING

Check that yield "f" is 20 mm (0.8 in) for a force "P" of 150 N (15 kg; 33 lb) applied midway on belt leg.

9. After adjustment, raise car on a platform lift and tighten alternator lower bolt previously started.

10. Lower car and connect alternator supply and indicator leads.

11 Complete installation reversing the removal procedure then operate as instructed in Hydraulic System Filling and Bleeding.

REPLACEMENT GASOLINE VERSION (4-cylinder)

Removal

1. Disconnect battery.
2. Empty power steering fluid reservoir using a syringe.
3. Back off and disconnect fittings ② and ③ from pump.
4. Slacken stretcher bracket ① capscrews. Slacken and remove drive belt.
5. Back off capscrews ⑦ and remove pump ④ with attached drive pulley and front bracket.

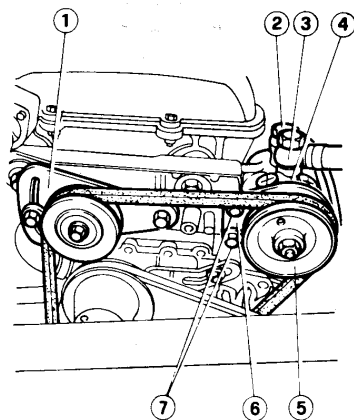

- 1 Belt stretcher bracket
- 2 Delivery pipe fitting
- 3 Return pipe fitting
- 4 Steering pump
- 5 Steering pump drive pulley
- 6 Front bracket
- 7 Front bracket capscrews

6. If necessary, remove pulley and front bracket from pump.

Installation

Install by reversing the removal sequence and adhering to the instructions given below:

- Move stretcher bracket and adjust drive belt tension: belt tension is correct when yield is 13 mm (0.5 in) under a 147 to 294 N (15 to 30 kg; 33 to 66 lb) force applied midway on belt leg.
- Adhere to the following tightening torques.

Tightening torques

Fluid return pipe fitting to steering pump fitting
45 to 50 N·m
(4.6 to 5.1 kg·m)
(33.2 to 36.9 ft·lb)

Fluid delivery pipe fitting to steering pump fitting
28 to 31 N·m
(2.9 to 3.2 kg·m)
(20.7 to 22.9 ft·lb)

- Operate as indicated in Hydraulic System Filling and Bleeding.

REPLACEMENT GASOLINE VERSION (6-cylinder)

Removal

1. Disconnect battery terminals and remove battery.
2. Empty power steering fluid reservoir using a syringe.
3. Back off and disconnect fittings ③ and ④ from pump.
4. Slacken three capscrews ① on front bracket ⑤ and two pump/rear bracket ② capscrews.
5. Move pump to slacken drive belt. Take belt off drive pulleys.

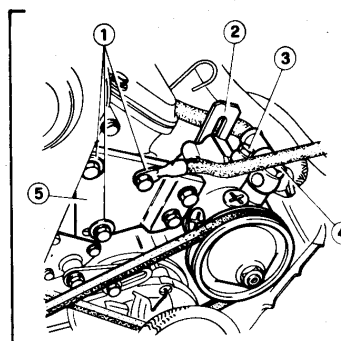

- 1 Front bracket/engine block capscrews
- 2 Front bracket
- 3 Delivery pipe fitting
- 4 Return pipe fitting
- 5 Front bracket

6. Back off and remove two capscrews ① and capscrews ②. Remove power steering pump.

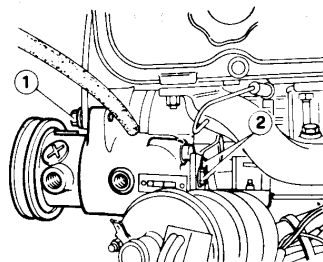

- 1 Pump/front bracket capscrew
- 2 Pump/rear bracket capscrews

7. If necessary, remove pump drive pulley.

Installation

Install by reversing the removal sequence and adhering to the instructions given below:

- Move pump to adjust drive belt tension: belt tension is correct when yield is 13 mm (0.5 in) under a 147 to 294 N (15 to 30 kg; 33 to 66 lb) force applied midway on belt leg.
- Adhere to the following tightening torques.

STEERING

T : Tightening torques

Fluid return pipe fitting to steering pump fitting

45 to 50 N·m
(4.6 to 5.1 kg·m)
(33.2 to 36.9 ft·lb)

Fluid delivery pipe fitting to steering pump fitting

28 to 31 N·m
(2.9 to 3.2 kg·m)
(20.7 to 22.9 ft·lb)

- Operate as instructed in Hydraulic System Filling and Bleeding.

HYDRAULIC SYSTEM FILLING AND BLEEDING

1. To top the tank with specified oil (AGIP ATF DEXRON B 11297; IP DEXRON FLUID B 11297) to the limit.
2. On the pump fitting, loosen the return pipe fitting from the reservoir to the pump until a little oil flows out and all air is bled.
3. Lock the fitting to the specified torque.

T : Tightening torque

Return pipe fitting on steering pump fitting.

45 to 50 N·m
(4.6 to 5.1 kg·m)
(33.2 to 36.9 ft·lb)

4. Start the engine and feed the tank until level settles.
5. With the engine running, carry out a few full steering locks to right and left, then top up the oil in the tank to the "Max" mark.
6. Reassemble the tank plug.

POWER STEERING LINES

REPLACEMENT

Applicable to all lines.

1. Place car on a platform lift and restrain rear wheels using suitable chocks.

CAUTION:

If the engine is warm proceed with caution.

2. Back off reservoir cap, draw fluid using a syringe and replace cap.
3. Having concluded, tighten the fittings to the specified torques and refill system as instructed in Hydraulic System Filling and Bleeding.
There are different procedures for the various types of piping.

Power steering unit piping

- a. Raise car and unscrew from the steering unit ① the pipe fittings ③ of the pipe ② being disconnected then remove the pipe.

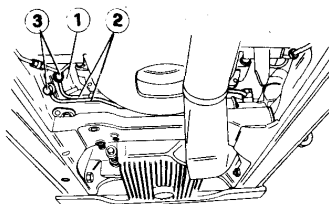

- 1 Power steering unit
- 2 Pipes
- 3 Fittings

- b. Install pipe reversing the removal sequence.

Steering unit/reservoir hose

Turbo diesel version.

- a. Remove battery together with plastic tray.
- b. Disconnect reservoir inlet hose by slackening clip.
- c. Raise car on a platform lift, disconnect reservoir hose fitting from steering unit and remove hose.
- d. Connect hose reversing the removal sequence.

Gasoline version.

Remove hose from lower fitting on steering unit and hose clip on reservoir.

Reservoir-pump and pump-steering unit connecting pipes

Turbo diesel version.

- a. Remove battery together with plastic tray.
- b. Remove air cleaner housing and alternator as specified in "Power Steering Pump - Removal" from para. 4 to para. 9.
- c. Back off pipe fittings from steering pump.
- d. If pipe to be removed connects reservoir to pump, slacken clip securing pipe to reservoir and disconnect. If pipe to be removed connects pump to steering unit, raise car and back off fitting securing pipe to steering unit; lower car.
- e. Free pipe from clips and remove.

WARNING:

- a. To facilitate assembly, first secure piping on pump side.
- b. Piping should not be excessively bent and must be aligned and secured to car through suitable clips.

Gasoline version.

- a. Remove clip and detach pipe from reservoir.
- b. Back off pipe fitting from steering pump.
- c. Raise car and disconnect pipe from steering unit; withdraw pipe through grommet on body.

WARNING:

1. To facilitate assembly, first secure piping on pump side.
2. Piping should not be excessively bent and must be aligned and secured to car through suitable clips.

STEERING

POWER STEERING FLUID RESERVOIR

REPLACEMENT

Turbodiesel version.

1. Remove battery together with plastic tray.
2. Back off fluid reservoir cap and draw fluid using a syringe.
3. Disconnect fluid outlet/inlet piping (4) and (5) by slackening associated clips.

CAUTION:

Hold piping ends up to prevent oil spillage.

4. Slacken reservoir clip bolt (3) and remove reservoir (1) by withdrawing it from clip (2).

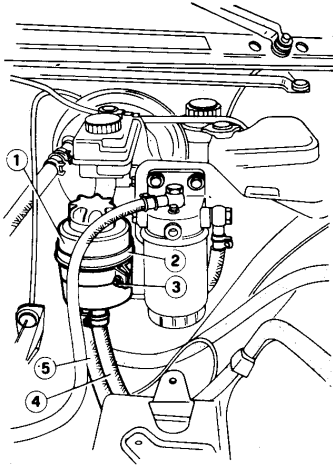

- 1 Power steering fluid reservoir.
- 2 Clip
- 3 Bolt
- 4 Reservoir outlet pipe
- 5 Reservoir inlet pipe

5. Install by reversing the removal sequence; fill reservoir with recommended fluid (AGIP ATF DEXRON B 11297; IP DEXRON FLUID B 11297; quantity 0.8 kg).

REPLACEMENT

Gasoline version.

1. Empty reservoir using a syringe.
2. Disconnect piping (1) from reservoir (3) by slackening clip screws.
3. Slacken clip screw (2) and remove reservoir by withdrawing it from clip (4).

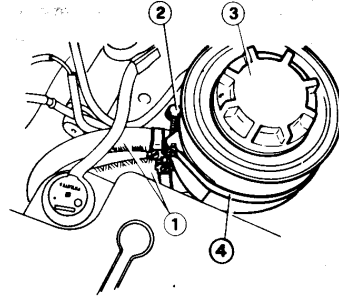

- 1 Fluid outlet/inlet piping
- 2 Clip screw
- 3 Fluid reservoir
- 4 Reservoir retaining clip

4. Install by reversing the removal sequence and fill reservoir with recommended fluid.

STEERING PUMP DRIVE BELT

REPLACEMENT

Turbo diesel version.

Steering pump drive bolt replacement necessitates alternator drive belt removal.

1. Place car on a platform lift and restrain rear wheels using suitable chocks.

CAUTION:

If the engine is warm proceed with caution.

2. Remove battery together with plastic tray.
3. Slacken bolt securing alternator to belt stretcher bracket.
4. Raise car and slacken alternator lower bolt. Lower car.

5. Move alternator to slacken belt and remove belt.
6. Back off 3 split pulley capscrews (1) and remove outer pulley half (2) together with tension spacers; remove belt.

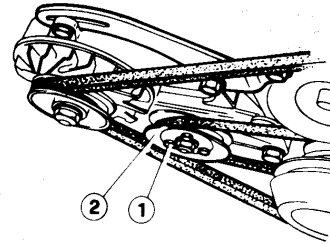

- 1 Capscrew
- 2 Outer pulley half

7. To install reverse the removal sequence and adhere to the instructions given below.

- Adjust steering pump belt tension until yield is 15 mm (0.6 in) for a force P of 147 ± 10 N (15 ± 1 kg; 33 ± 2 lb) applied midway on belt leg. To adjust, alter spacers between pulleys half; increase spacer thickness to reduce belt tension and vice versa.
- Adjust alternator belt until yield f is 20 mm (0.8 in) for a force P of 147 ± 10 N (15 ± 1 kg; 33 ± 2 lb) applied midway on belt leg.

REPLACEMENT

Gasoline version - 4-cylinder.

1. Slacken capscrews (1) and (3), push belt stretcher bracket (2) downward and take off belt.
2. Install new belt over the three drive pulleys and move stretcher bracket to obtain the specified tension.
Belt tension is correct when yield is 13 mm (0.5 in) for a force P of 147 to 294 N (15 to 30 kg; 33 to 66 lb) applied midway on belt leg.
3. Fully tighten capscrew (1), recheck belt tension and tighten capscrew (3).

STEERING

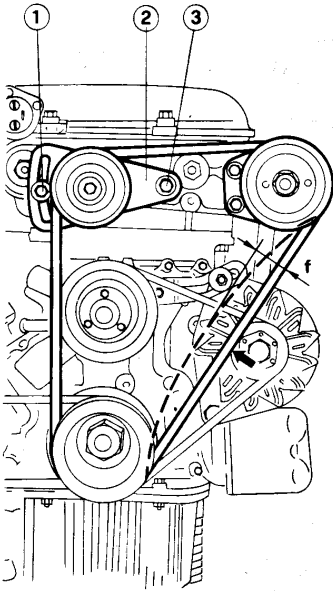

- 1 Capscrew
- 2 Stretcher bracket
- 3 Capscrew

REPLACEMENT

Gasoline version - 6-cylinder.

1. Slacken three capscrews ① retaining front bracket to engine and two capscrews retaining pump ③ to rear bracket.
2. Move pump ③ to loosen belt; remove belt.
3. Install belt and move pump to adjust belt tension. Tighten front/rear bracket capscrews.
4. Check that yield f is 13 mm (0.5 in) for a 147 to 294 N (15 to 30 kg; 33 to 66 lb) load P applied midway on belt leg.

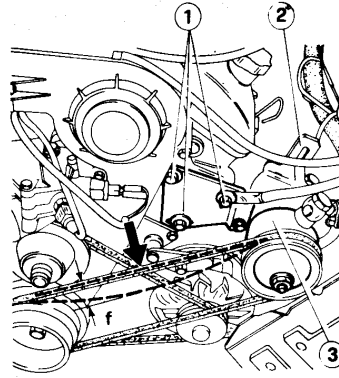

- 1 Front bracket to engine block capscrews
- 2 Rear bracket
- 3 Steering pump
- 4 Front bracket

STEERING

MECHANICAL STEERING

MECHANICAL STEERING UNIT

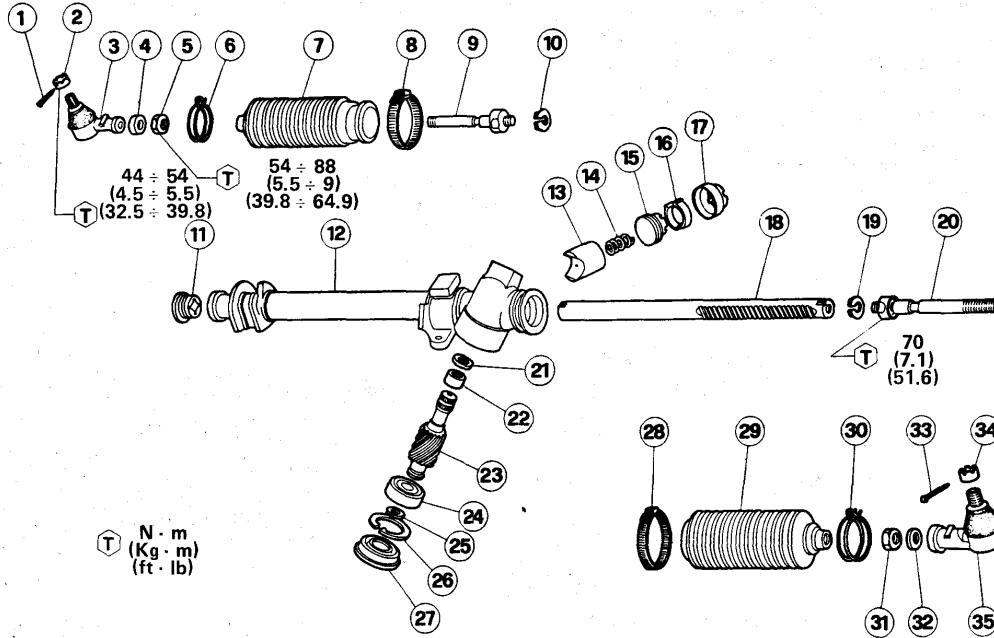

- | | | |
|-----------------|---------------------------|--------------------------|
| 1 Cotter pin | 14 Spring | 26 Pinion retaining ring |
| 2 Nut | 15 Adjusting screw | 27 Lower cover |
| 3 Ball joint | 16 Spring | 28 Inner clip |
| 4 Washer | 17 Cover | 29 Bellows |
| 5 Locknut | 18 Rack | 30 Outer clip |
| 6 Outer clip | 19 Retainer | 31 Locknut |
| 7 Bellows | 20 Tie rod | 32 Washer |
| 8 Inner clip | 21 Seal | 33 Cotter pin |
| 9 Tie rod | 22 Pinion bushing | 34 Nut |
| 10 Retainer | 23 Pinion | 35 Ball joint |
| 11 Rack bushing | 24 Bearing | |
| 12 Rack housing | 25 Bearing retaining ring | |
| 13 Piston | | |

STEERING

REMOVAL

1. Place car on a platform lift, apply parking brake and slacken front wheel nuts.
2. From engine compartment, back off steering unit cover capscrews, and remove cover.
3. Take off cotter pin ① back off and remove U-joint ③ bolt ② connecting intermediate shaft to pinion and separate joint from pinion.

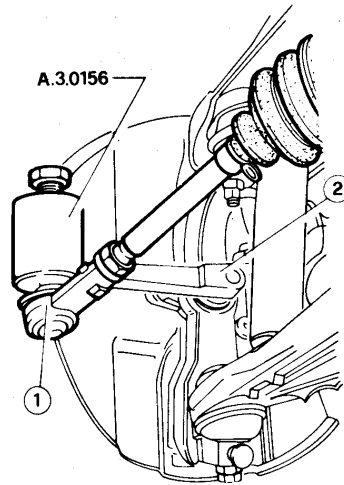

- 1 Ball joint
- 2 Steering knuckle

5. Back off capscrews ① and remove bracket ② and support ③ from right side.

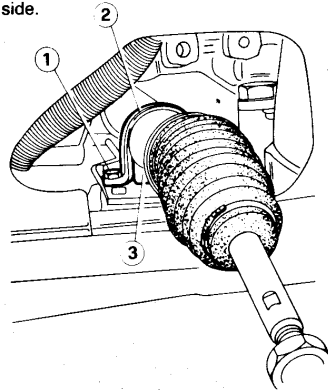

- 1 Bracket/crossmember capscrew
- 2 Bracket
- 3 Support

6. Back off steering unit/crossmember capscrews from left side.
7. Take off steering unit from opening in left side panel.

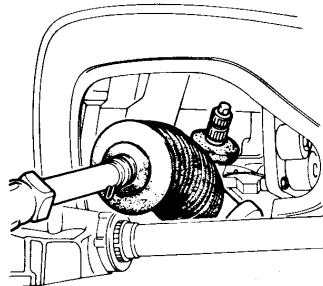

DISASSEMBLY

1. Clamp steering unit ① in a vice and slacken two ball joint ③ locknuts ② reacting on tie rods ④ applying a wrench to flats on tie rods.

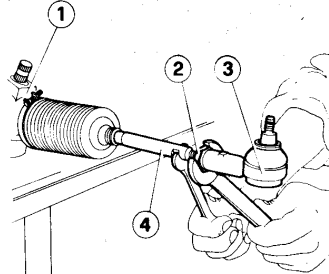

- 1 Steering unit
- 2 Locknut
- 3 Ball joint
- 4 Tie rod

2. Back off ball joints and remove bellows clips ① and ②.

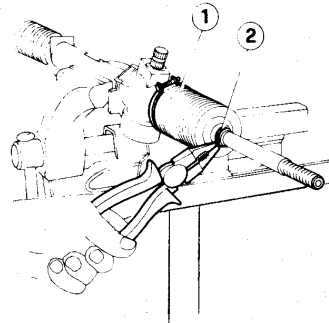

- 1 Inner clip
- 2 Outer clip

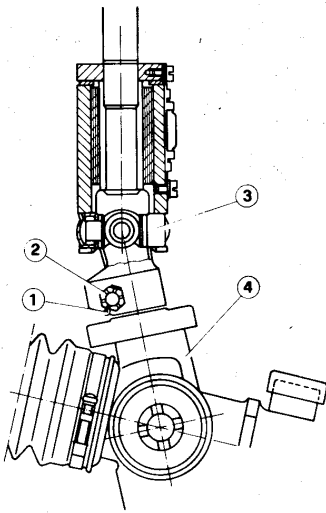

- 1 Cotter pin
- 2 U-joint/steering unit bolt
- 3 U-joint
- 4 Steering unit

4. Remove cotter pin, back off nuts and remove ball joint pins ① from steering knuckles ② using tool A.3.0156.

STEERING

3. Take off bellows and straighten retainers ①.

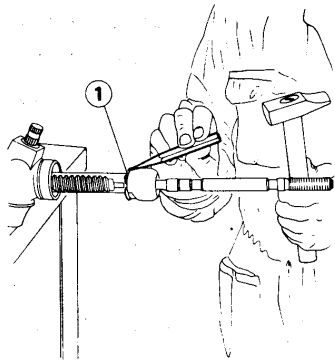

1 Retainer

4. Take off rack ① from teeth side, clamp in a vice provided with protective liners, back off and remove two tie rods ②.

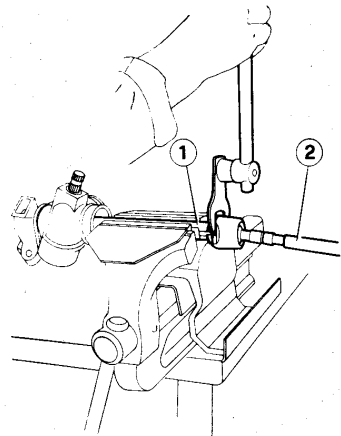

1 Rack
2 Tie rod

5. Remove rubber support from rack housing.
6. Remove pinion lower cover ① protecting pinion ②.

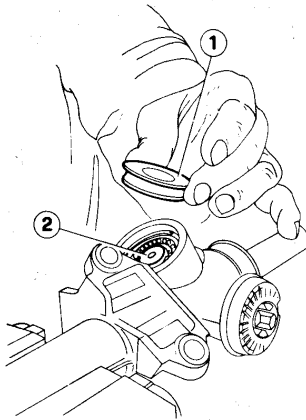

1 Lower cover
2 Pinion

7. Remove pinion bearing to rack housing ② retaining ring ①.

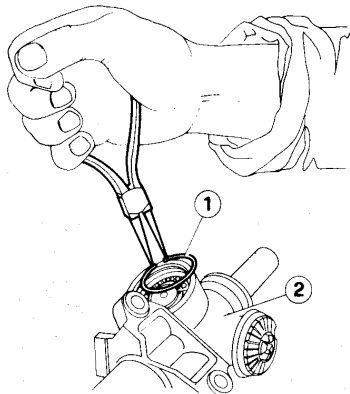

1 Retaining ring
2 Rack housing

8. Remove adjusting screw cover ① from rack housing.
9. Remove clicking spring ② from adjusting screw.
10. Back off adjusting screw ③, take off spring ④ and backlash take-up piston ⑤ controlling clearance between rack housing and rack.

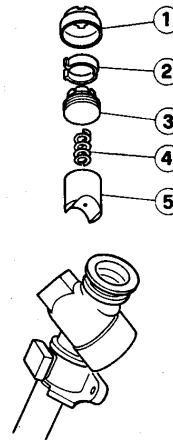

1 Cover
2 Spring
3 Adjusting screw
4 Spring
5 Piston

11. Using a plastic mallet, remove pinion with attached bearing from rack housing.

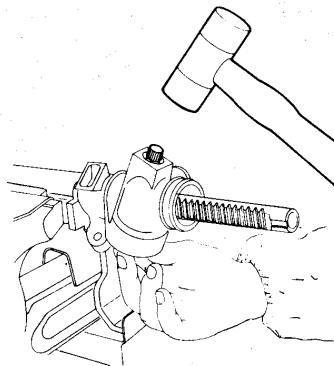

12. Remove rack.
13. Remove rack bushing ① on side opposite to steering pinion.

STEERING

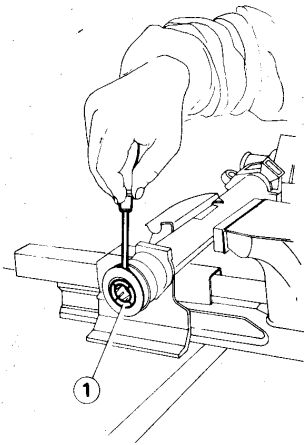

1 Rack bushing

14. Remove seal (1) from steering unit.

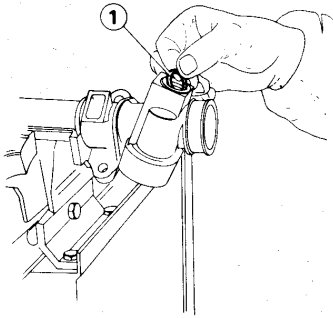

1 Seal

15. Take off pinion bushing from steering unit.

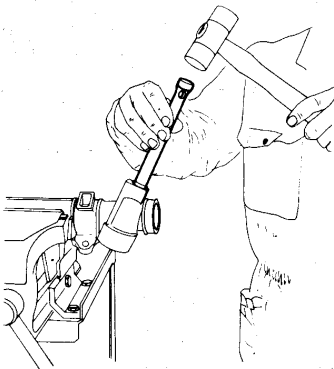

16. Remove bearing (2) to pinion (3) retaining ring (1).

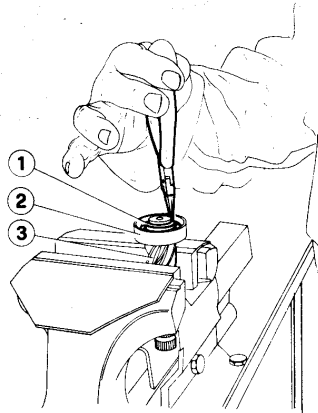

- 1 Retaining ring
- 2 Bearing
- 3 Pinion

17. Disassemble bearing (1) from pinion (2).

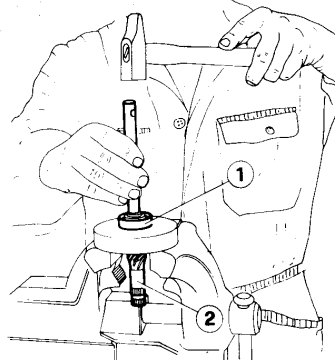

- 1 Bearing
- 2 Pinion

INSPECTION

Clean all parts.

Bellows

Check bellows for cracks or score marks and replace as necessary.

Rack

Check rack and pinion teeth for oxidation, score marks or dents and replace as necessary.

Self-lubricating bushings

Check self-lubricating bushings for wear; replace as necessary.

Rack housing

Check that pinion surface in contact with bushings is smooth and not worn.

Ball joints

Check ball joints for damage or wear. They should rotate without binding or excessive play; replace as necessary.

Tie rods

Check tie rods for damage or distortion; replace as necessary.

ASSEMBLY

Assemble by reversing the removal sequence and adhering to the instructions given below.

1. Install bearing (1) on pinion (2).

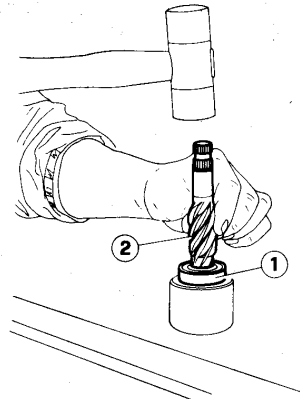

- 1 Bearing
- 2 Pinion

STEERING

- Insert bearing retaining ring on pinion and check that it is properly seated.
- Install self-lubricating bushing in steering unit.

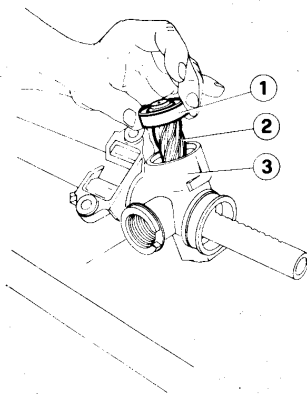
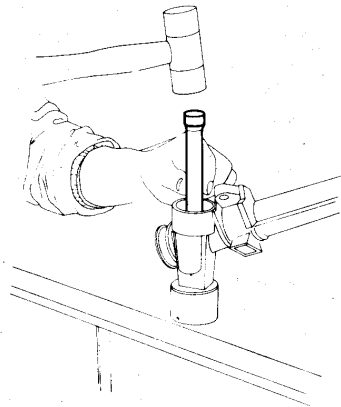

- Bearing
- Pinion
- Rack housing

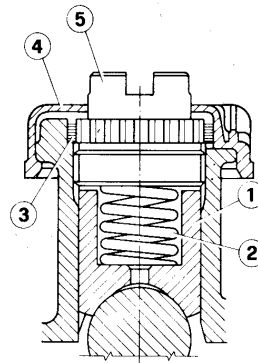

- Piston
- Spring
- Spring
- Cover
- Adjusting screw

- Insert a new seal in steering unit.
- Pack steering unit recess with 90 g of grease (AGIP F1 Grease 33 FD or IP Autogrease FD) and lubricate pinion bushing.
- Insert bushing (1) in rack housing ensuring that the two projections (2) engage the associated seats (3).

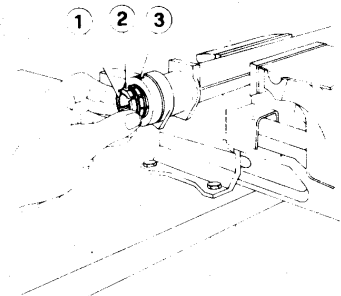

- Rack bushing
- Projection
- Seat

- Lubricate rack using grease as per para. 5 and insert in rack housing.
- Insert pinion (2) with attached bearing (1) in rack housing (3).

- Install pinion as shown in figure.

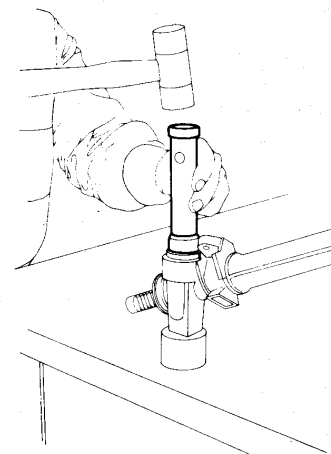

- Insert pinion retaining ring ensuring that it is properly seated.
- Install pinion lower cover.
- Lubricate backlash take-up piston and adjusting screw using grease as per para. 5.
- Insert backlash take-up piston (1), spring (2) and adjusting screw (5). Insert spring (3) and cover (4).

- Tighten adjusting screw to 3 N·m (0.3 kg·m) (2.2 ft·lb). Back off screw through 3 notches (equal to 3 clicks on spring). Check rack travel for binding.

CAUTION:

After a brief trial, check adjustment.

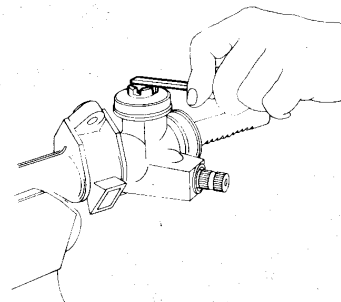

- Install retainers and tie rods (1) and tighten to the specified torque.

T: Tightening torque

Tie rod on rack.

70 N·m
(7.1 kg·m)
(51.6 ft·lb)

STEERING

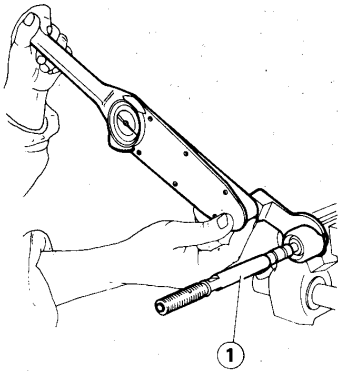

1 Tie rod

Steering installation length

$M = 399.5 \text{ mm (15.73 in)}$

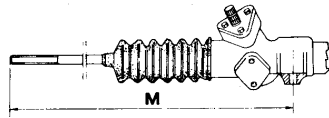

19. Install two ball joints on tie rods and tighten nuts at the specified dimension.

Tie rod ball joint installation dimension

$N = 26 \text{ mm (1.02 in)}$

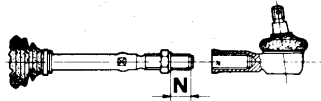

16. Bend two retainers.
17. Pack outer recess between housing and rack with grease as per para. 5; install two bellows and secure through clips.
18. Prepare steering for installation positioning rack at the specified dimension.

INSTALLATION

Install by reversing the removal sequence and adhering to the instructions given below.

- Position wheels in straight-ahead driving posture and check spoke centralization before connecting U-joint sleeve to steering pinion.
- Apply recommended grease (ISECO Molykote Pasta G) to steering column upper bracket.
- Adjust front wheel toe-out (see Group 00 - Wheel Alignment).
- Adhere to the following tightening torques.

Tightening torques

Ball joints locknut (on steering tie rod)

54 to 88 N · m
(5.5 to 9 kg · m)
(39.8 to 64.9 ft · lb)

Tie rod ball joint locknut (on steering knuckle)

45 to 55 N · m
(4.5 to 5.5 kg · m)
(33.2 to 40.6 ft · lb)

Steering unit to crossmember cap-screws

27 to 30 N · m
(2.7 to 3 kg · m)
(19.9 to 22.1 ft · lb)

INSPECTION SPECIFICATIONS

GENERAL REQUIREMENTS

FLUIDS AND LUBRICANTS

Description	Type	Recommended product	Quantity
Needle roller bushing housings (on steering column support)	GREASE	SPCA: Spagraph ISECO: Ergon Rubber Grease n. 3 REINACH Sferul B2 AR Part. no. 3671-69816	
Steering unit inner chamber Rack Outer recess between housing and rack Pinion bushing Backlash take-up piston Backlash adjusting screw Steering column support lower bearing Alfa 90	GREASE	AGIP: F1 Grease 33 FD IP: Autogrease FD Part. no. 3671-69833	90 g 3.17 oz.

STEERING

Description	Type	Recommended product	Quantity
Mating surfaces of steering wheel adjustment guides on column. Steering column and sliding sleeve spline.	GREASE	ISECO: Molykote Pasta G Part. no. 3671-69840	
ZF steering rack	OIL	Calypsol Part. no. 3671-69838	
Power steering fluid	OIL	AGIP: ATF DEXRON B 11297 IP: DEXRON FLUID B 11297 Part. no. 3631-69525	0.8 kg 1.76 lb

CHECKS AND ADJUSTMENTS

MECHANICAL STEERING

Steering installation dimension

M = 399.5 mm (15.73 in)

Tie rod ball joint installation dimension

N = 26 mm (1.02 in)

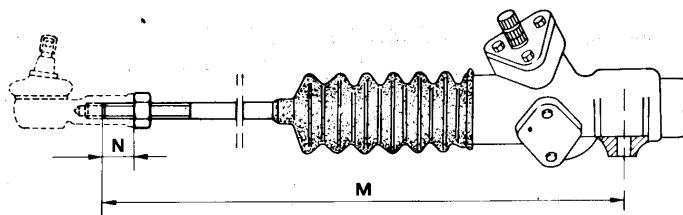

POWER STEERING

Steering installation dimension

LHD M = 399.5 mm (15.73 in)

RHD M = 394 mm (15.51 in)

Tie rod ball joint installation dimension

N = 26 mm (1.02 in)

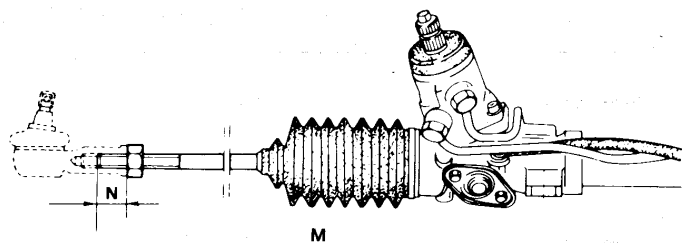

HYDRAULIC POWER STEERING SYSTEM FILLING

1. Before starting engine, fill the tank with recommended oil to the limit.
2. On the pump, loosen the feeding pipe fitting (this pipe leads the oil from the reservoir to the pump) until a little oil flows out and all air is bled.
3. Lock the fitting to the specified torque.
4. Start the engine and feed the tank until level settles.
5. With the engine running, carry out a few full steering locks to right and left, then top up the oil in the tank to the "Max" mark.
6. Reassemble the tank plug.

STEERING

TIGHTENING TORQUES [N·m (kg·m; ft·lb)]

Description	Alfa 90	Alfa 75	Alfa Romeo
			Giulietta GTV 2.0 GTV 6 2.5
Tie rod on rack	70 (7,1) (51.6)		70 (7,1) (51.6)
Capscrews, steering unit to crossmember	26 to 29 (2.7 to 3) (19.2 to 21.4)		26 to 29 (2.7 to 3) (19.2 to 21.4)
Locknut, ball joint on tie rod	54 to 88 (5.5 to 9) (39.8 to 64.9)		54 to 88 (5.5 to 9) (39.8 to 64.9)
Nut, tie rod ball joint	44 to 54 (4.5 to 5.5) (32.5 to 39.8)		44 to 54 (4.5 to 5.5) (32.5 to 39.8)
Bolt, intermediate shaft/pinion shaft U-joint (Tighten further to permit cotter pin insertion)	15 (1.5) (11.1)		15 (1.5) (11.1)
Bolts, intermediate shaft/steering column U-joint			15 to 24 (1.5 to 2.4) (11.1 to 17.7)
Bolt, steering column to lower support on body	4.9 to 7.35 (0.5 to 0.75) (3.6 to 5.4)		13 to 16 (1.3 to 1.6) (9.6 to 11.8)
Nut, steering column to upper support on body (steering wheel lever locked)	21 to 26 (2.1 to 2.6) (15.5 to 19.2)		21 to 26 (2.1 to 2.6) (15.5 to 19.2)
Nut, steering column intermediate shaft sliding sleeve (nut must be tightened to obtain specified sliding load on spline)	34 to 44 (3.5 to 4.6) ⁽¹⁾ (7.6 to 9.9)		
Nut, steering wheel on steering column	28 to 32 (2.9 to 3.3) (20.6 to 23.6)		30 to 35 (3.1 to 3.6) (22.1 to 25.8)

⁽¹⁾ [N (kg)]
(lb)

Power steering, specific data

Tie rod on rack	63 to 77 (6.4 to 7.8) (46.5 to 56.8)
Oil delivery pipe on power steering pump fitting	28 to 31 (2.9 to 3.2) (20.7 to 22.9)
Oil return pipe adapter on power steering pump fitting	45 to 50 (4.6 to 5.1) (33.2 to 36.9)
Oil delivery pipe adapter on control valve fitting	22 to 24 (2.2 to 2.4) (16.2 to 17.7)
Oil return pipe adapter on control valve fitting	38 to 43 (3.9 to 4.4) (28 to 31.7)
Oil pipe fittings on steering unit	20 (2) (14.8)

STEERING

TROUBLESHOOTING

POWER STEERING

Preliminary operations:

- Check tyre for pressure and wear
- Check vehicle trim and wheel alignment
- Place car on level and dry floor and run engine at idle speed.

Fault	Cause	Remedy
Low fluid level in reservoir	<ul style="list-style-type: none"> • Normal air expulsion during operation • Defective control valve seal • Leakage through steering unit and pump fittings 	Top up reservoir Replace steering unit Tighten fittings to the specified torque; replace fittings seals if necessary
Fluid level drops after topping up (even in the absence of visible leakage)	Defective steering unit seals and fluid leakage into bellows	Replace steering unit
Hard steering	<ul style="list-style-type: none"> • Low rpm at idle • Steering unit leakage • Low pump delivery pressure • Loose pump drive belt • Failed pump 	Adjust engine rpm Replace steering unit Adjust belt tension Replace pump
Hard steering persists after pump replacement	Defective steering unit	Install pump previously removed and replace steering unit
Noisy power steering system	<ul style="list-style-type: none"> • Insufficient fluid • Air in system • Loose fittings on intake side <p>NOTE Foam in reservoir</p> <ul style="list-style-type: none"> • Worn pump shaft seal • Fluid reservoir filter clogged • Loose power steering screws • Damaged or worn tie rods and/or ball joints 	Top up and rotate steering wheel in both directions from lock to lock to bleed system Tighten fittings to the specified torque Replace pump Replace reservoir Tighten to the specified torque Replace tie rods and/or ball joints
Damaged bellows	External agents and/or rubber aging	Replace bellows



STEERING

MECHANICAL STEERING

Fault	Cause	Remedy
Noisy intermediate shaft	<ul style="list-style-type: none"> • Excessive U-joint play • Excessive column-intermediate shaft spline backlash 	Replace intermediate shaft Replace defective parts
Excessive column-intermediate shaft spline sliding	<ul style="list-style-type: none"> • Excessive wear • Insufficient adjusting nut tightening 	Replace defective parts Correctly tighten nut
Noisy steering column	<ul style="list-style-type: none"> • Worn and/or damaged column bearing • Column fouling cowl • Loose bolts securing column to upper and lower supports 	Replace defective parts Install cowl correctly Tighten correctly
Difficult axial and radial steering wheel adjustment	<ul style="list-style-type: none"> • Column-shaft sliding sleeve nut excessively tight • Insufficient lower column support guide clearance • Excessively tight column/upper support nut • Insufficient lubrication on sliding surfaces of column supports and column/shaft spline 	Tighten correctly Replace lower bolt spacer Tighten correctly Lubricate
Excessive steering wheel play	<ul style="list-style-type: none"> • Loose steering unit capscrews • Damaged tie rods or U-joints 	Tighten screws Replace defective parts
Noisy steering	<ul style="list-style-type: none"> • Loose steering unit capscrews • Worn steering linkage • Excessive pinion/rack backlash 	Tighten screws Replace defective parts Adjust backlash
Hard steering	<ul style="list-style-type: none"> • Incorrect suspension geometry • Worn or under-inflated tyres • Insufficient pinion/rack backlash • Insufficient lubrication • Damaged U-joints • Steering column fouling turn signal switch unit 	Adjust Check and replace or adjust Adjust backlash Lubricate Replace U-joints Check for correct turn signal switch unit installation

STEERING

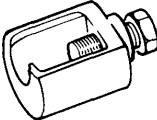
SPECIAL TOOLS

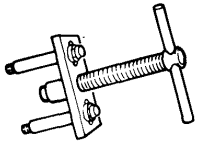
Part No.	Description	Page
A.3.0156	Puller steering lever ball joint 	23-14 23-24
A.3.0346	Installer, column and steering unit bushings 	23-10
A.3.0451	Puller, steering wheel 	23-3