

EXTERNAL TRIMMING

GROUP 75

CONTENTS

EXTERNAL MOLDING	75-2	Front bumper	75-10
Drip cover molding	75-2	Rear bumper	75-12
Rear pillars molding	75-3	APRON	75-13
[DOOR STRIP	75-4	COWL TOP COVER	75-14
RADIATOR GRILLE	75-5	SERVICE DATA AND SPECIFICA-	
WINDOWS	75-6	TIONS	75-15
Windscreen	75-6	General specifications	75-15
Rear window	75-9	SPECIAL SERVICE TOOLS	75-15
BUMPERS	75-10		

EXTERNAL MOLDING

DRIP COVER MOLDING

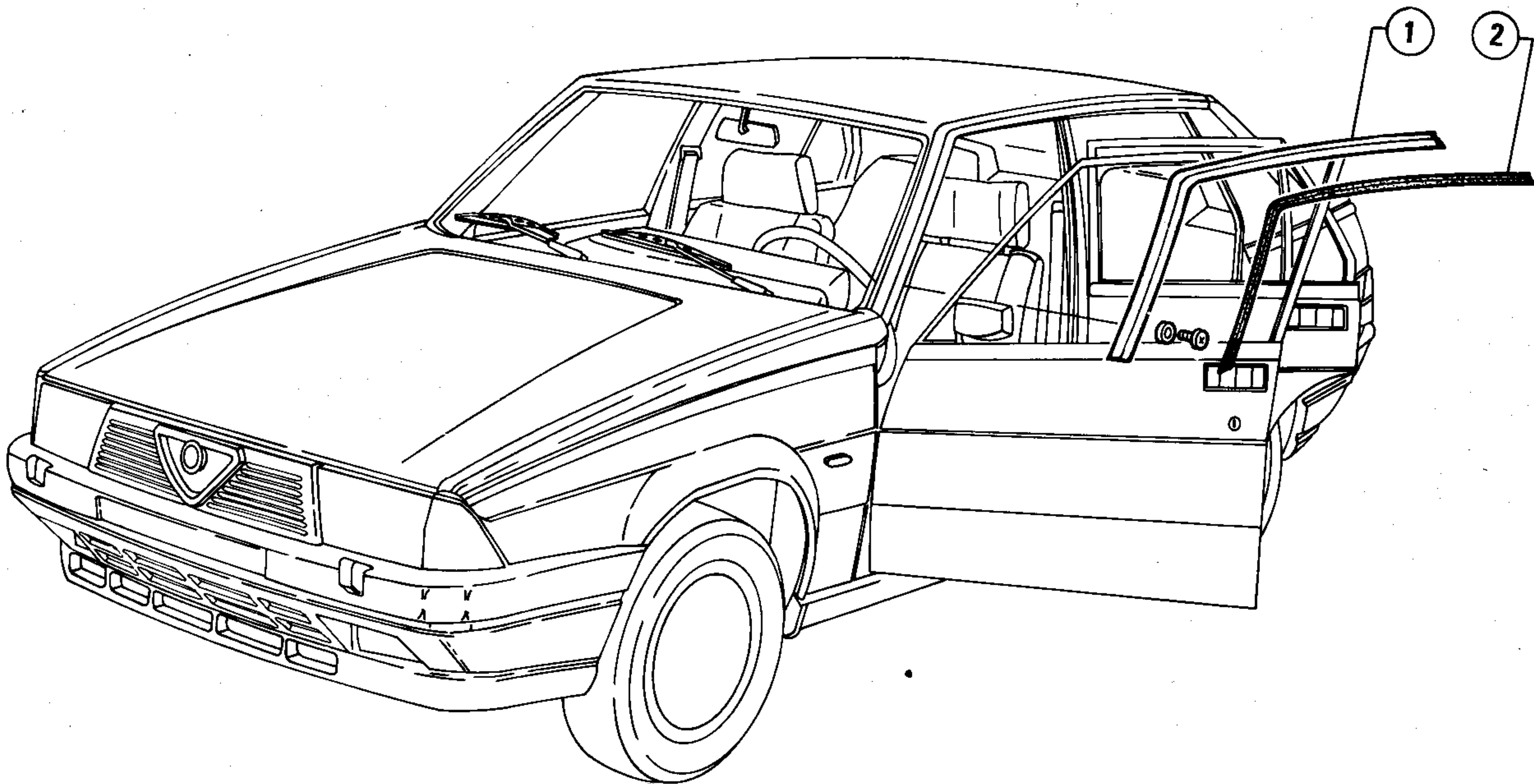

- 1 Drip cover molding
- 2 Rubber sealing

REMOVAL AND INSTALLATION

1. Open the door and remove the rubber sealing (1) that has been pushed into place.

2. Unscrew the eight screws securing drip cover molding (2) to body, and remove it.

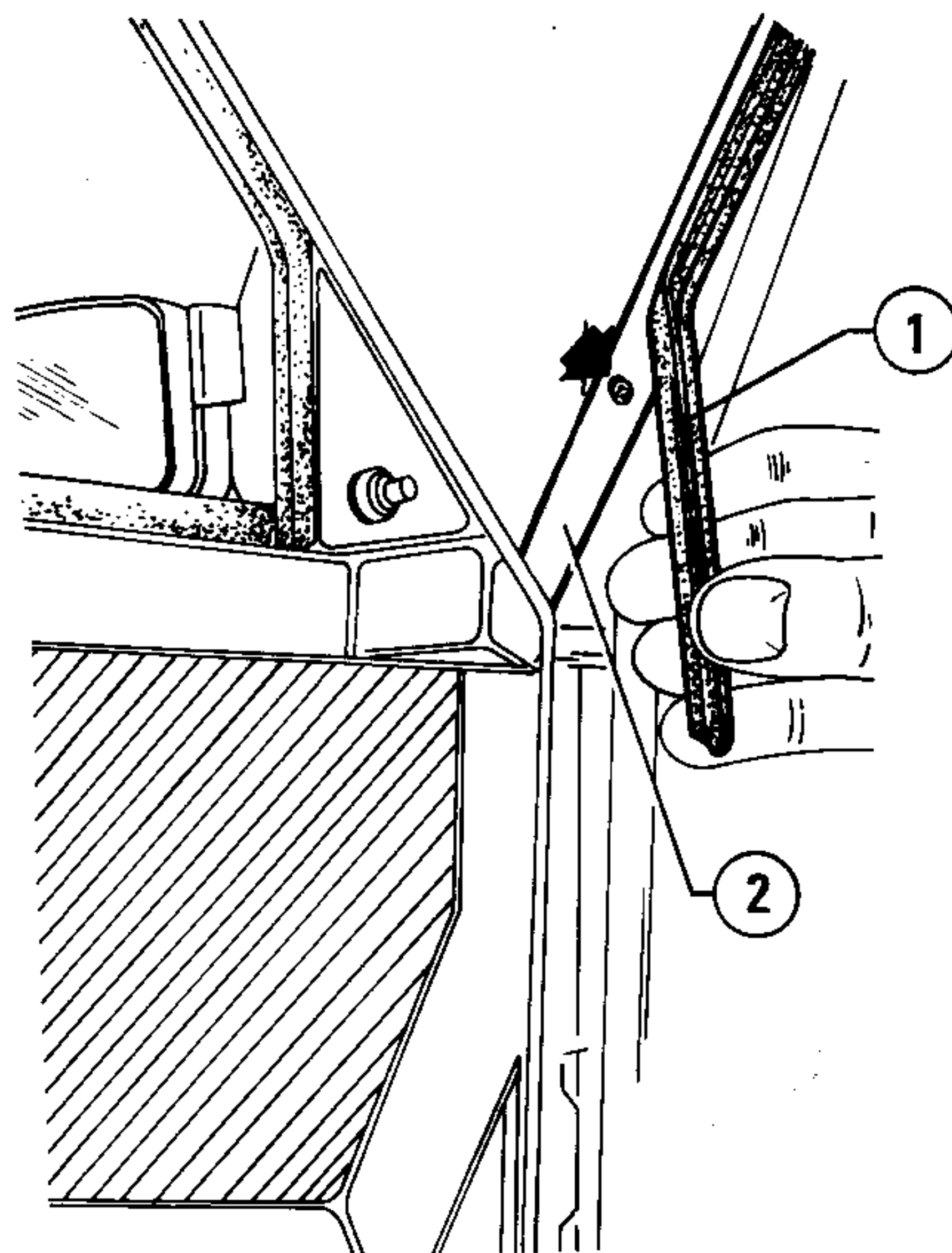

3. Install the drip cover molding by reversing the order of removal.

- 1 Rubber sealing
- 2 Drip cover molding

EXTERNAL TRIMMING

REAR PILLARS MOLDING

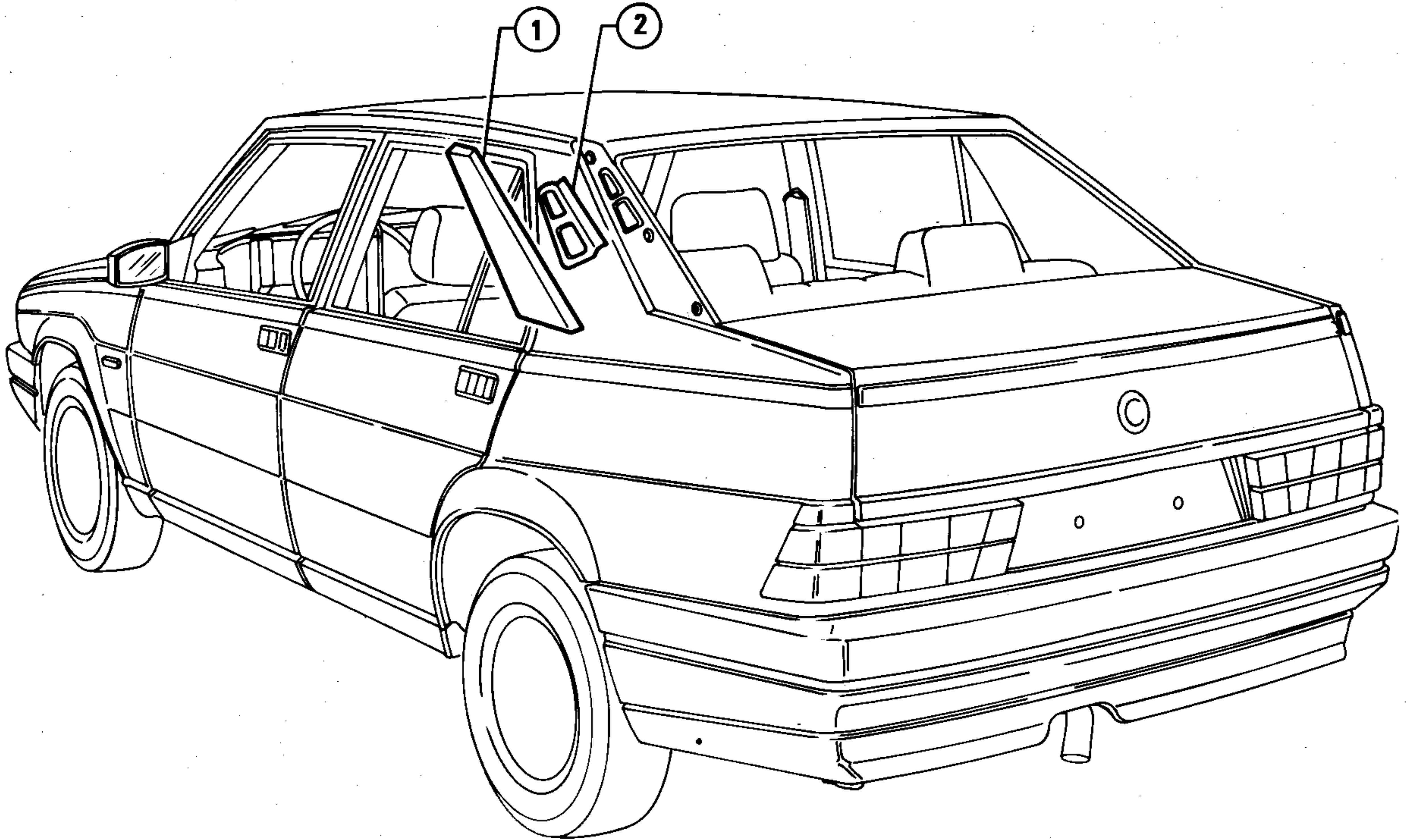

- 1 Pillar molding
- 2 Air outlet gasket

REMOVAL AND INSTALLATION

1. Operating as per figure, remove the pillar molding from the three clamps securing it to body, after heating the lower side of molding itself with a jet of warm air.

2. Install the pillar molding by reversing the order of removal.

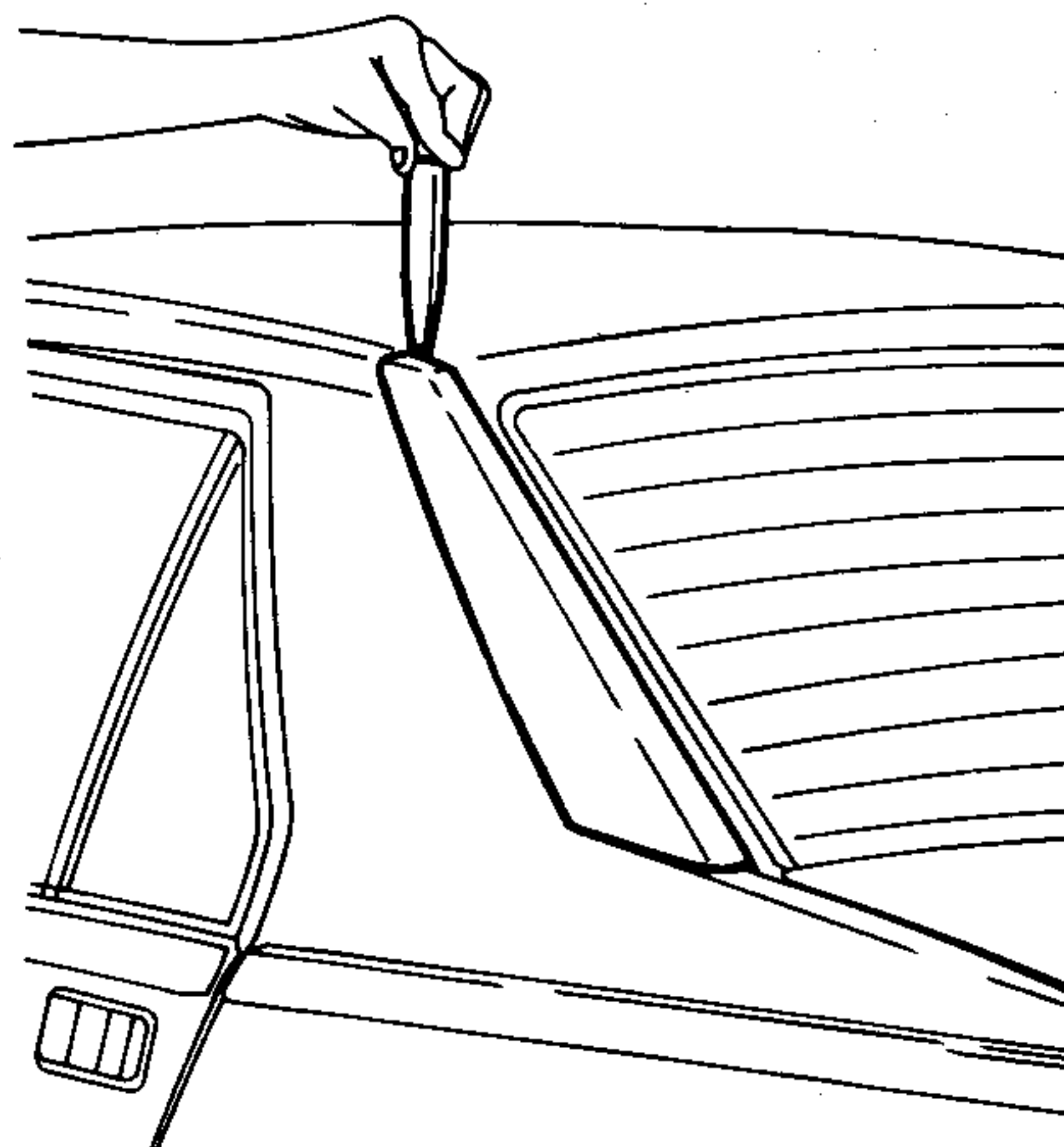

CAUTION:

The air outlet gasket (refer to: item ② of exploded view) has been pushed into its seat on rear fender with the edge towards the rear window. When installing, take care not to exchange the component of the right-hand bumper with that of left-hand bumper.

DOOR STRIP

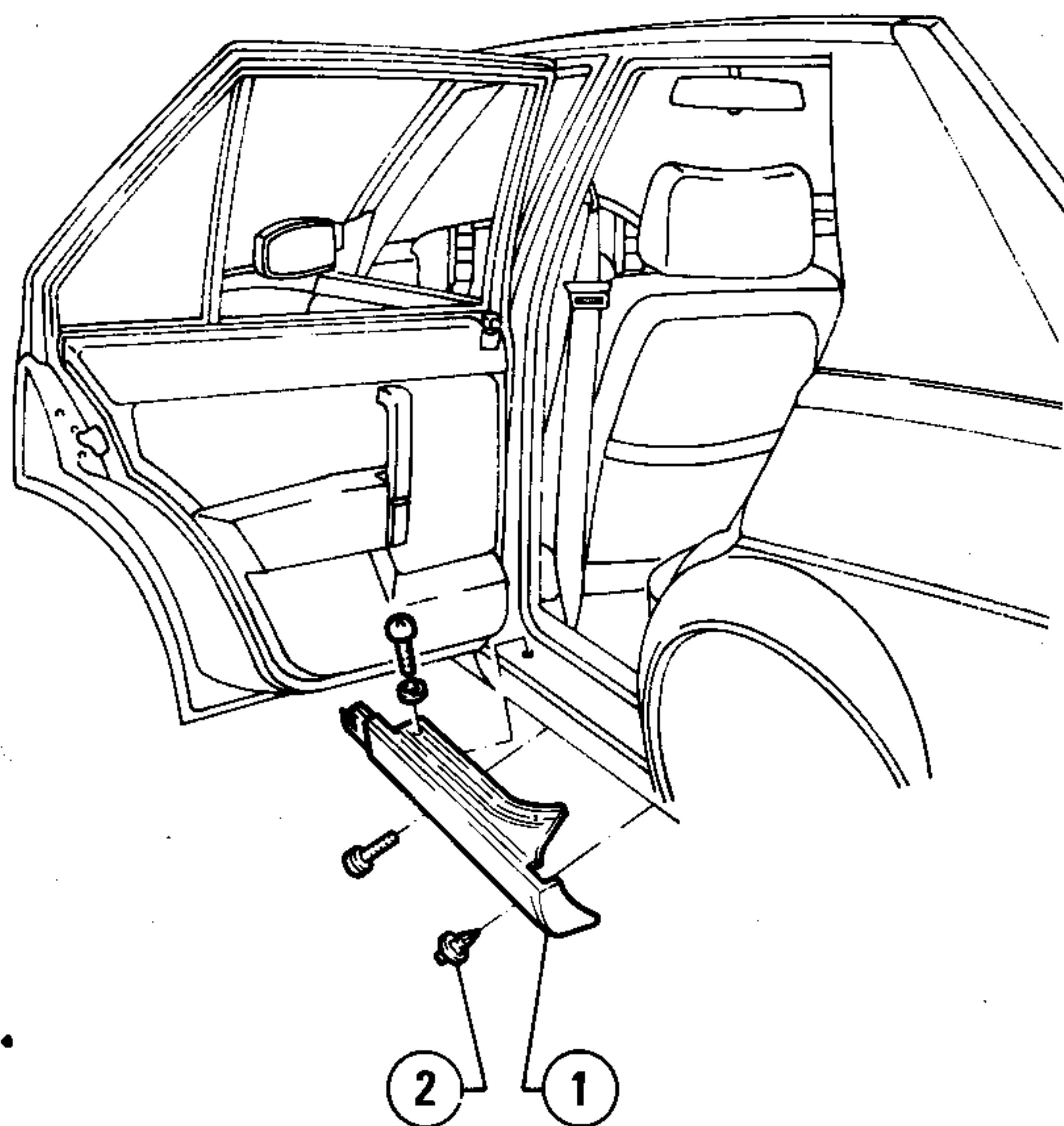
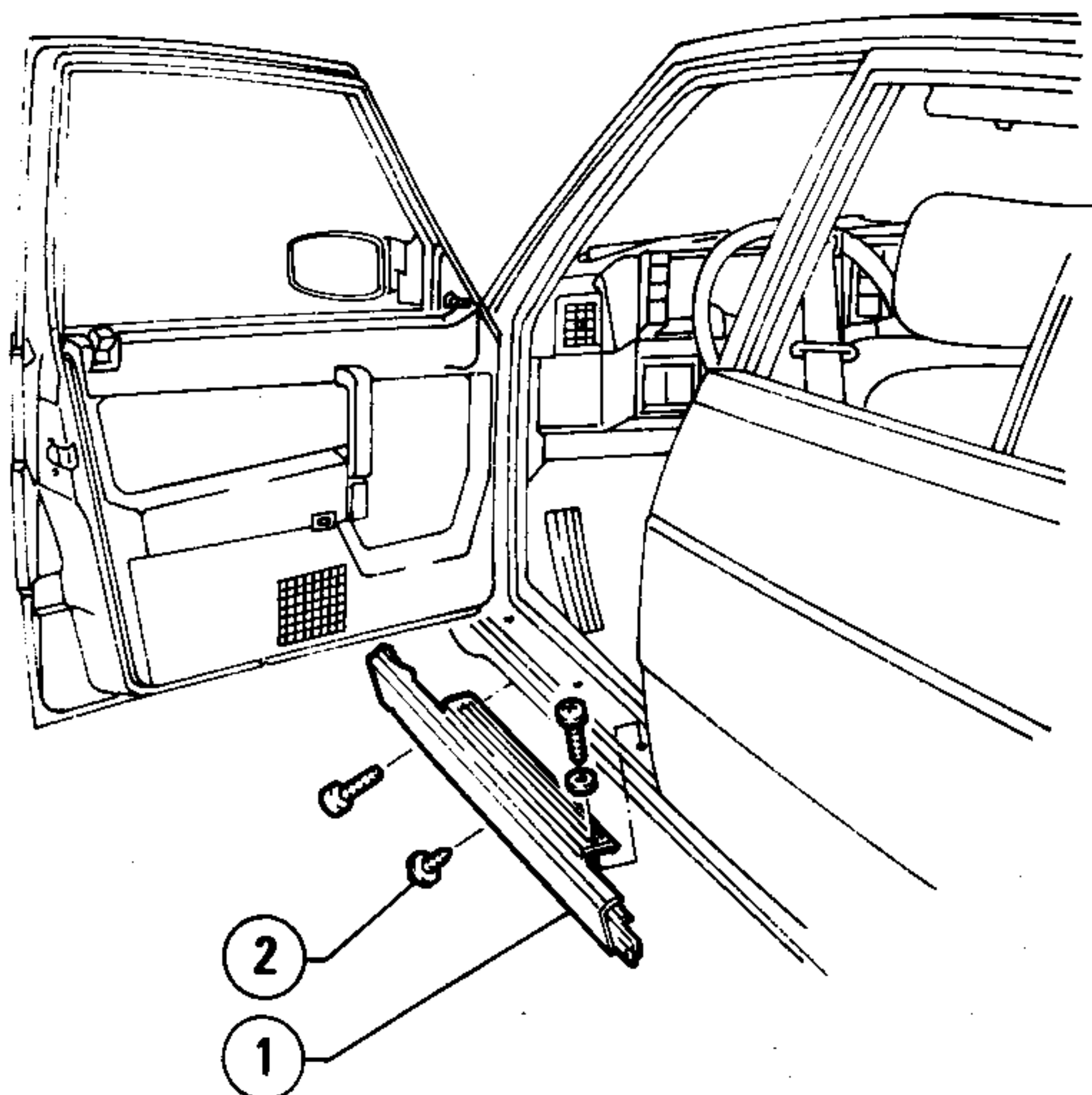

- 1 Door strip
- 2 Plastic rivets

REMOVAL AND INSTALLATION

1. Open the doors and unscrew the three front and the two rear screws securing the two door strips to body.

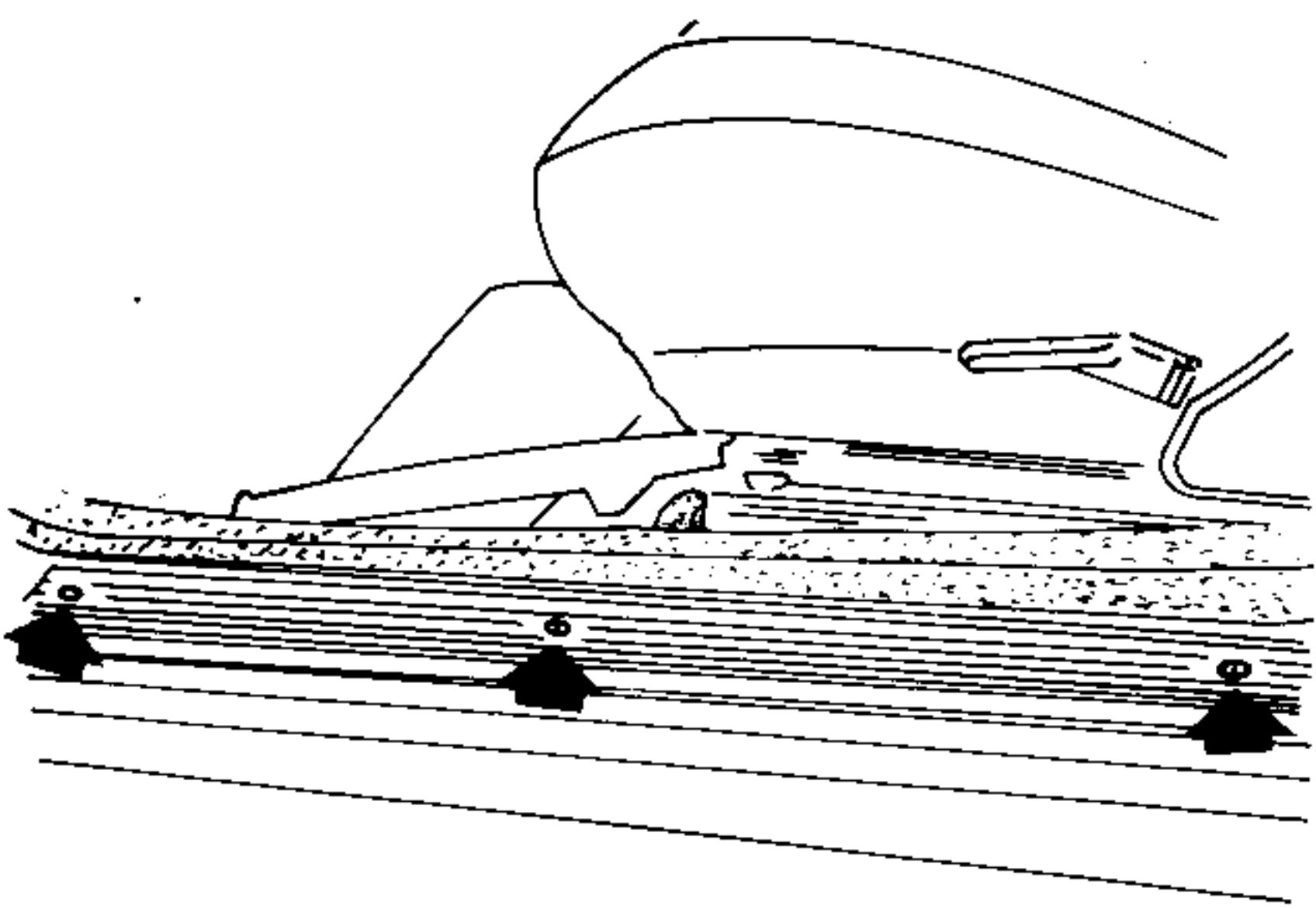

2. Unscrew screw (1) securing the two door strips to body.
 3. By means of pliers extract the five rivets (2) securing the strips and remove the two components.

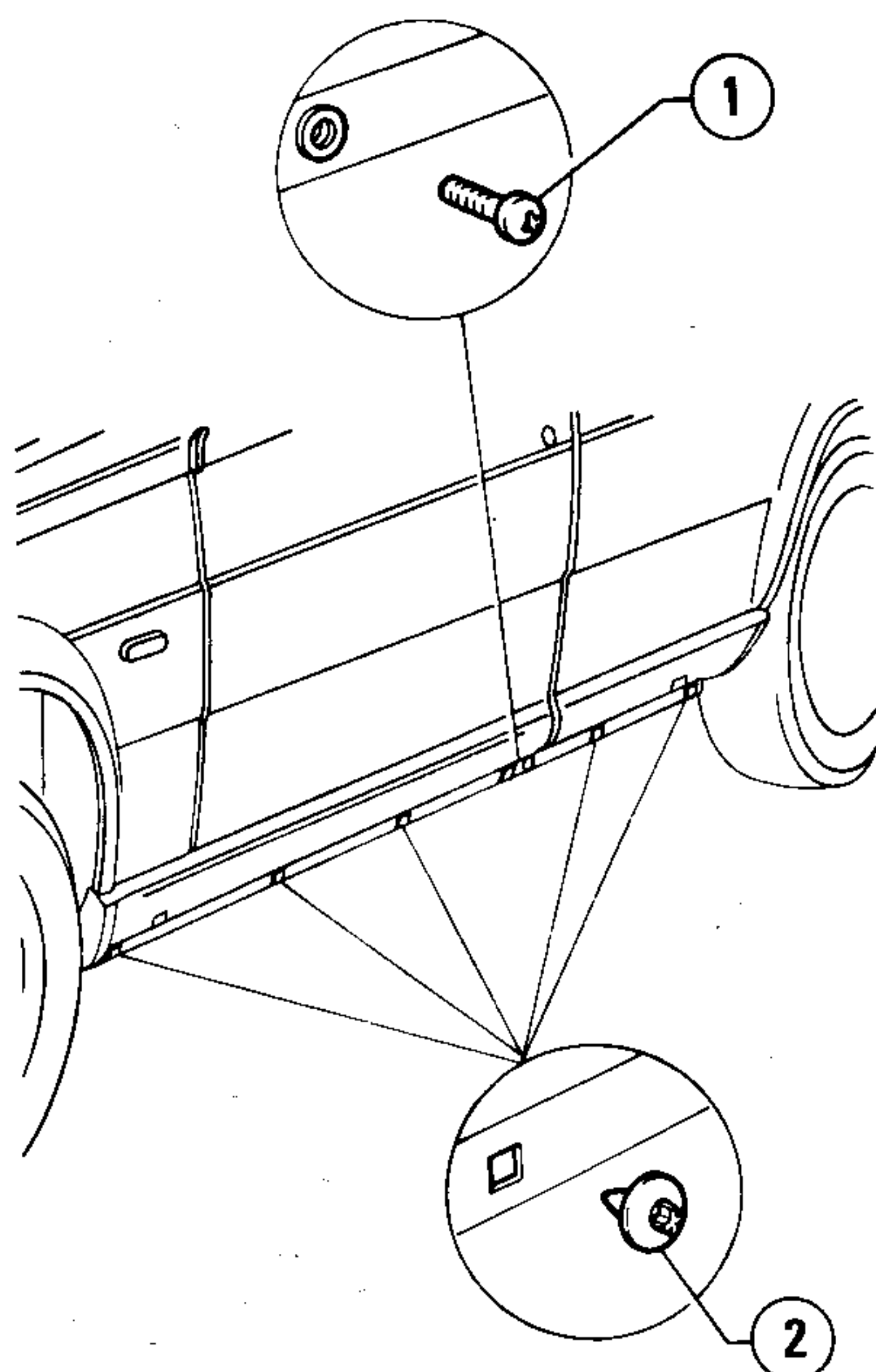

- 1 Screw
- 2 Plastic rivets

4. Install the door strip by reversing the order of removal. Should the door strip be installed on a new door under-trim, use strip itself as a template to mark off the centre of the holes by operating as directed in "Body - Sheet Metal Panels - Door under-trim".

RADIATOR GRILLE

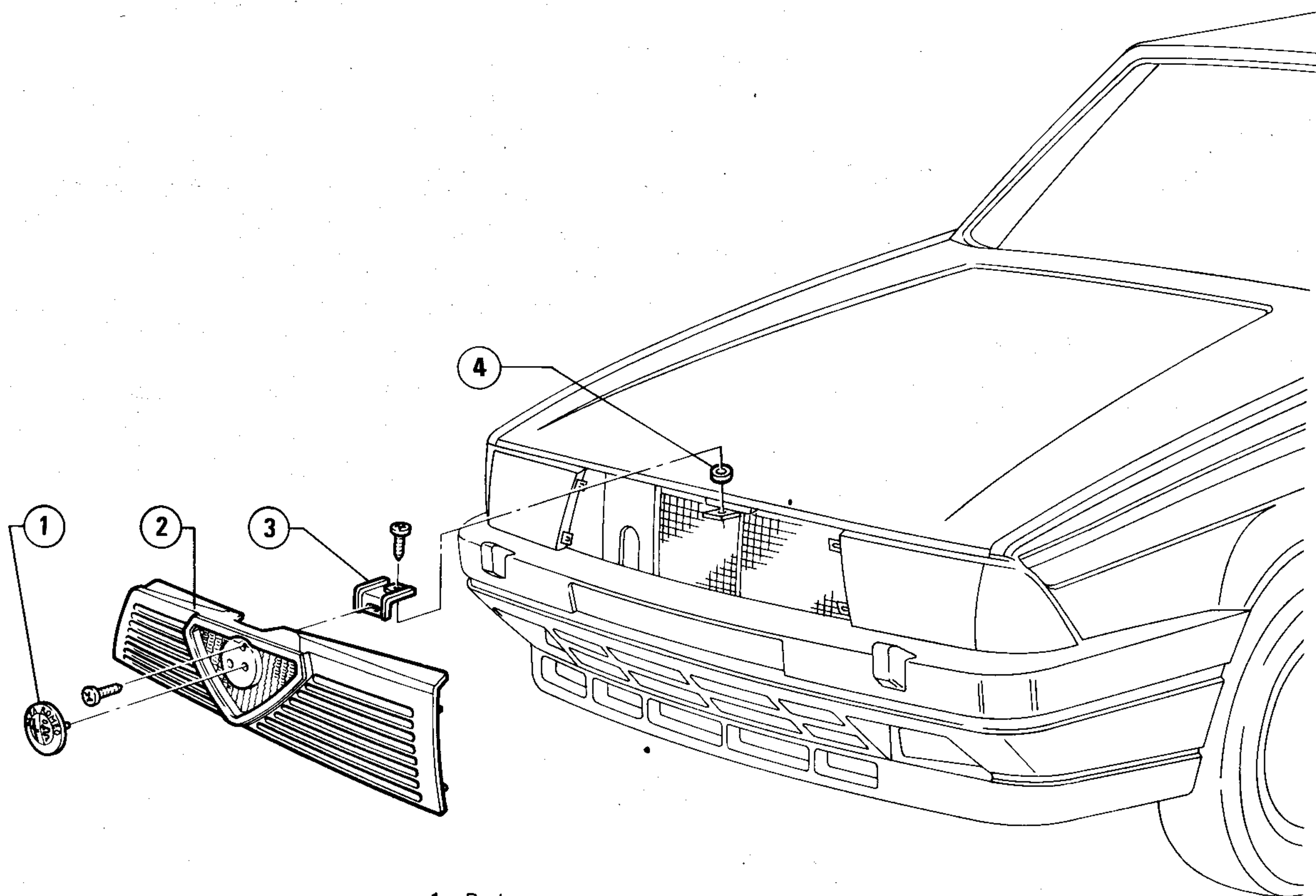

- 1 Badge
- 2 Grille
- 3 Bracket
- 4 Spacer

REMOVAL AND INSTALLATION

1. Remove the badge and unscrew the screw securing grille to bracket.

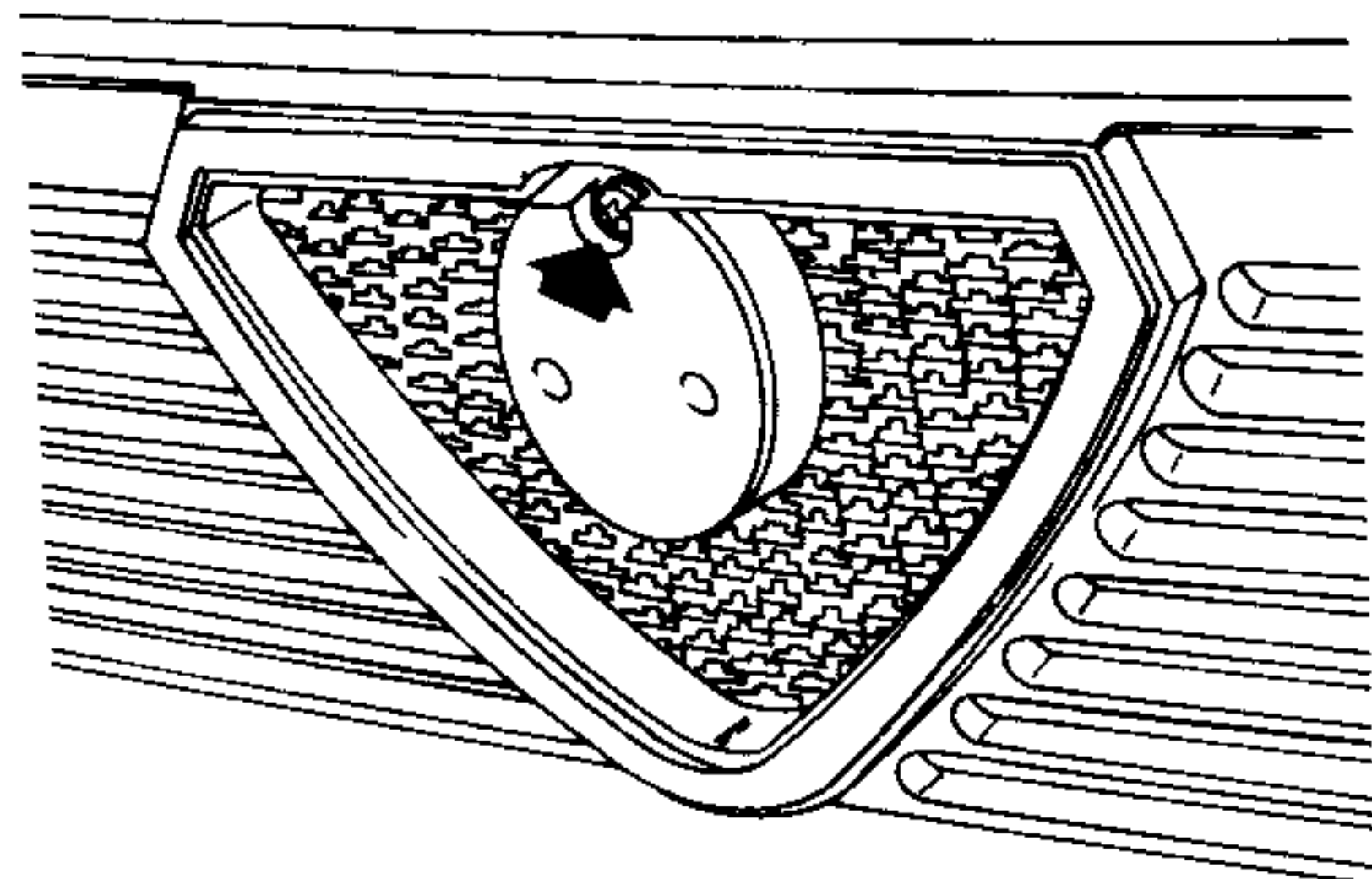

2. Remove the grille with suitable tool.

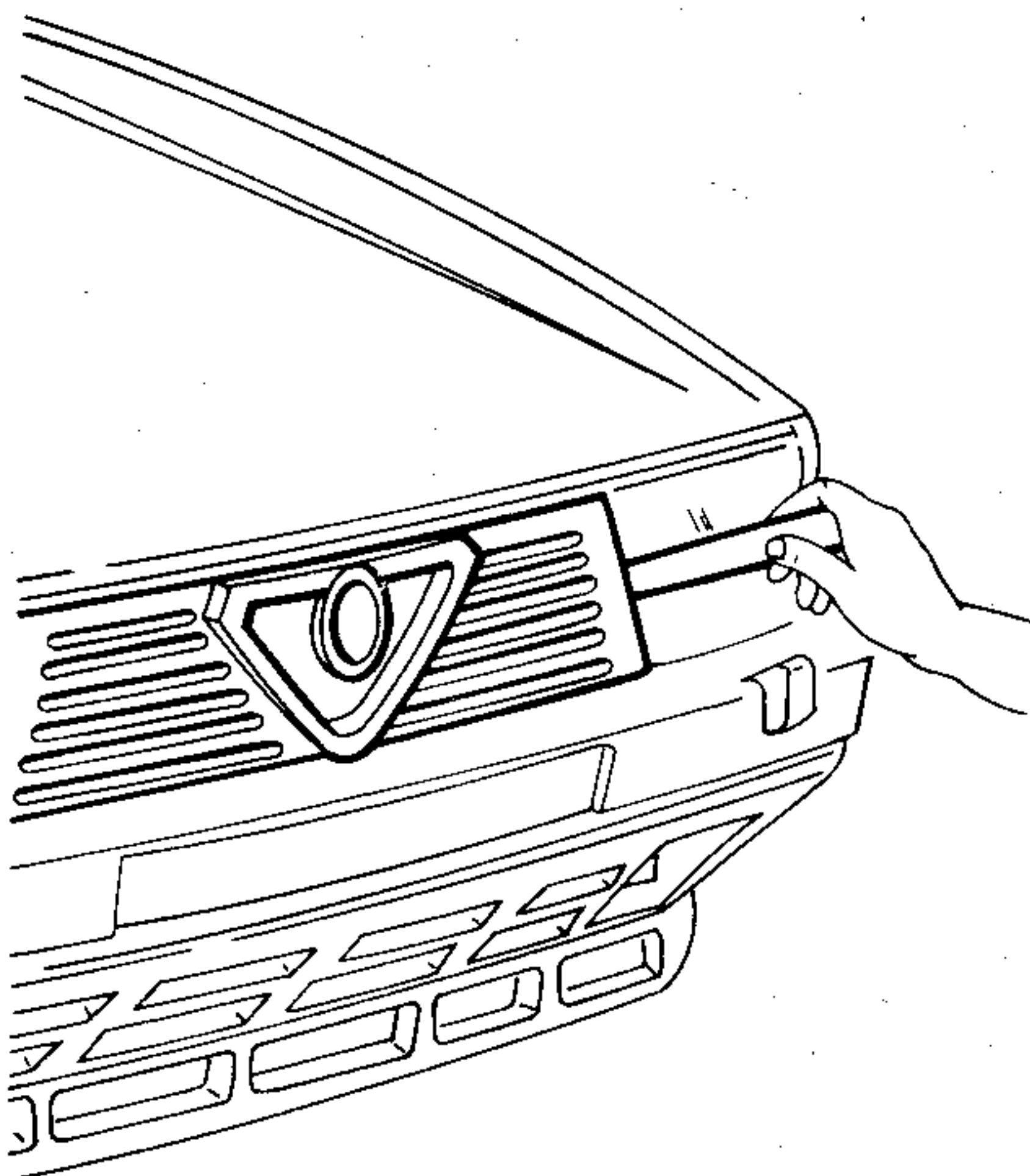

3. Install the grille by reversing the order of removal.

CAUTION:

- Since the grille is made of plastic, take care not to exert too much force when performing the various operations.
- Take care to keep mineral oil away from the grille.

WINDOWS

WINDSCREEN

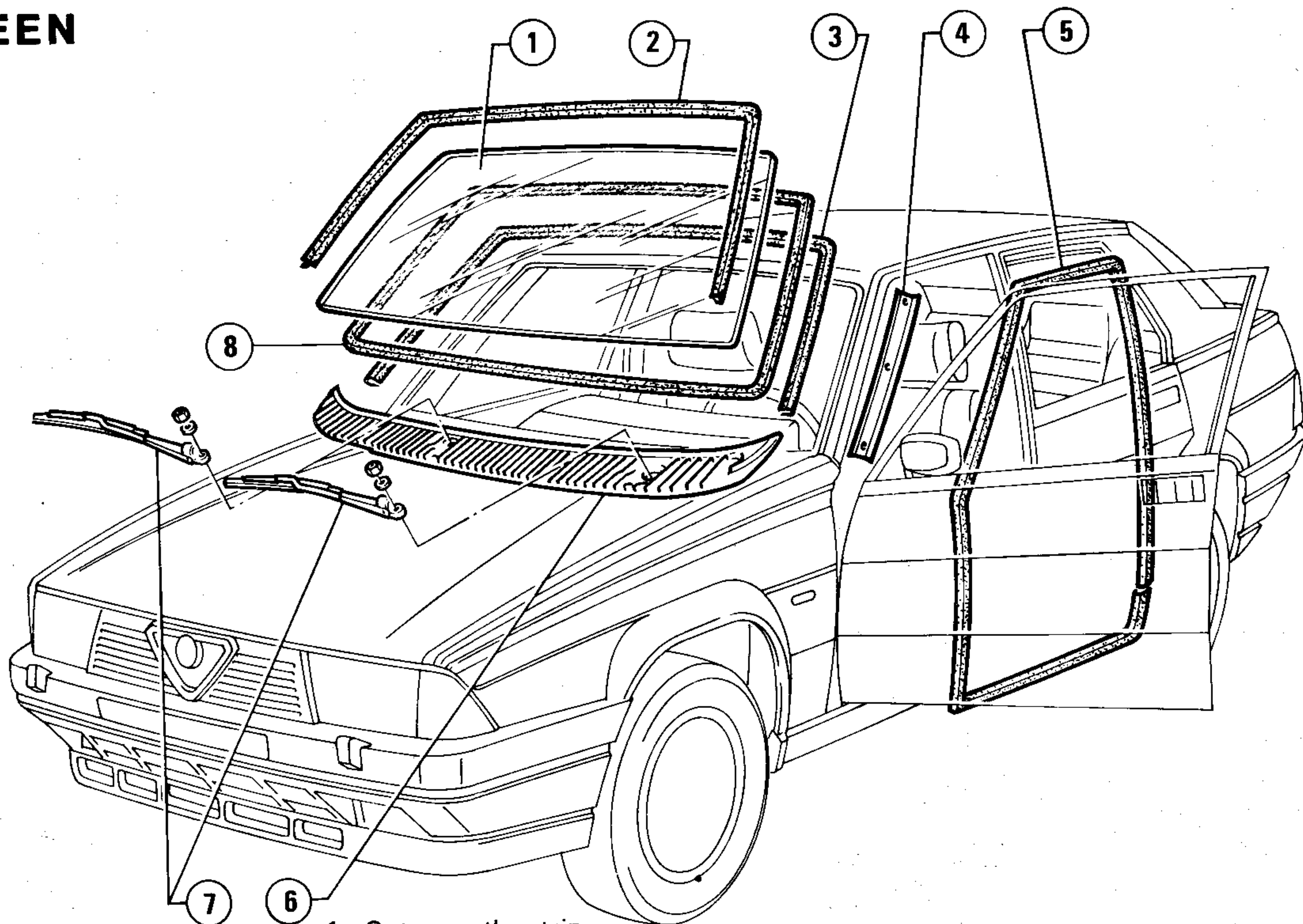

- 1 Outer weatherstrip
- 2 Windscreen
- 3 Glue seal
- 4 Adhesive edging
- 5 Front pillar trim
- 6 Door opening seal
- 7 Cowl top cover
- 8 Wiper arms

REMOVAL

1. Operating from inside the passenger compartment, remove seals (1) in the section where they cover trims (2). Remove the trims that have been pushed into place.

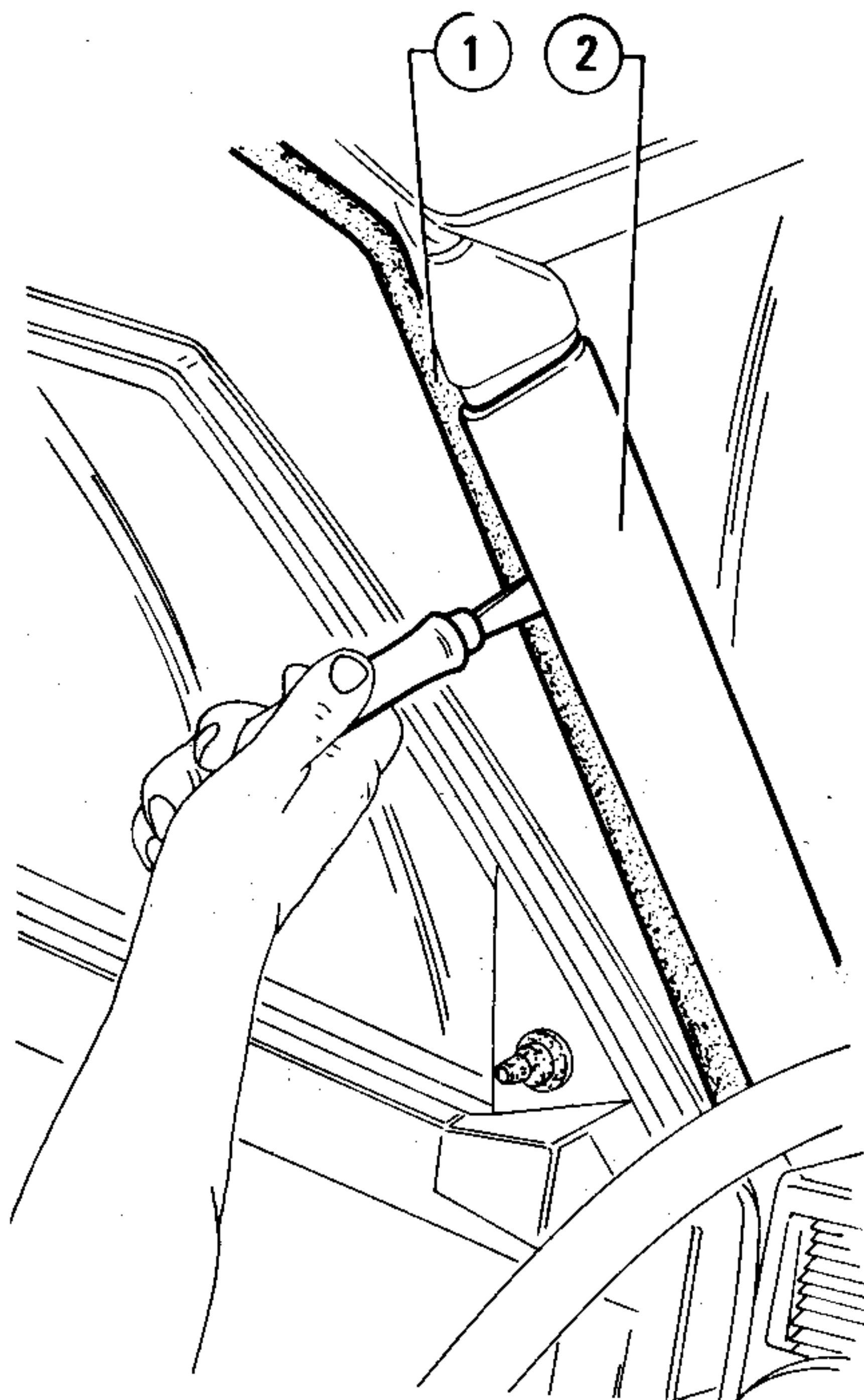

- 1 Door opening seal
- 2 Front pillar trim

- 2. Remove the windscreen wiper arms and the cowl top cover (refer to: "Cowl Top Cover").
- 3. Using a suitable tool, remove the outer weatherstrip (item 1 of the exploded view).
- 4. Free one end of the steel wire from one of the handgrips of tool A.9.0060. Drill the sealant and insert the steel wire in correspondance with an angular area of the window, then block the end of the wire in the handgrip.
- 5. Cut the sealant all along the window perimeter as indicated in the figure. Remove the window carefully.

EXTERNAL TRIMMING

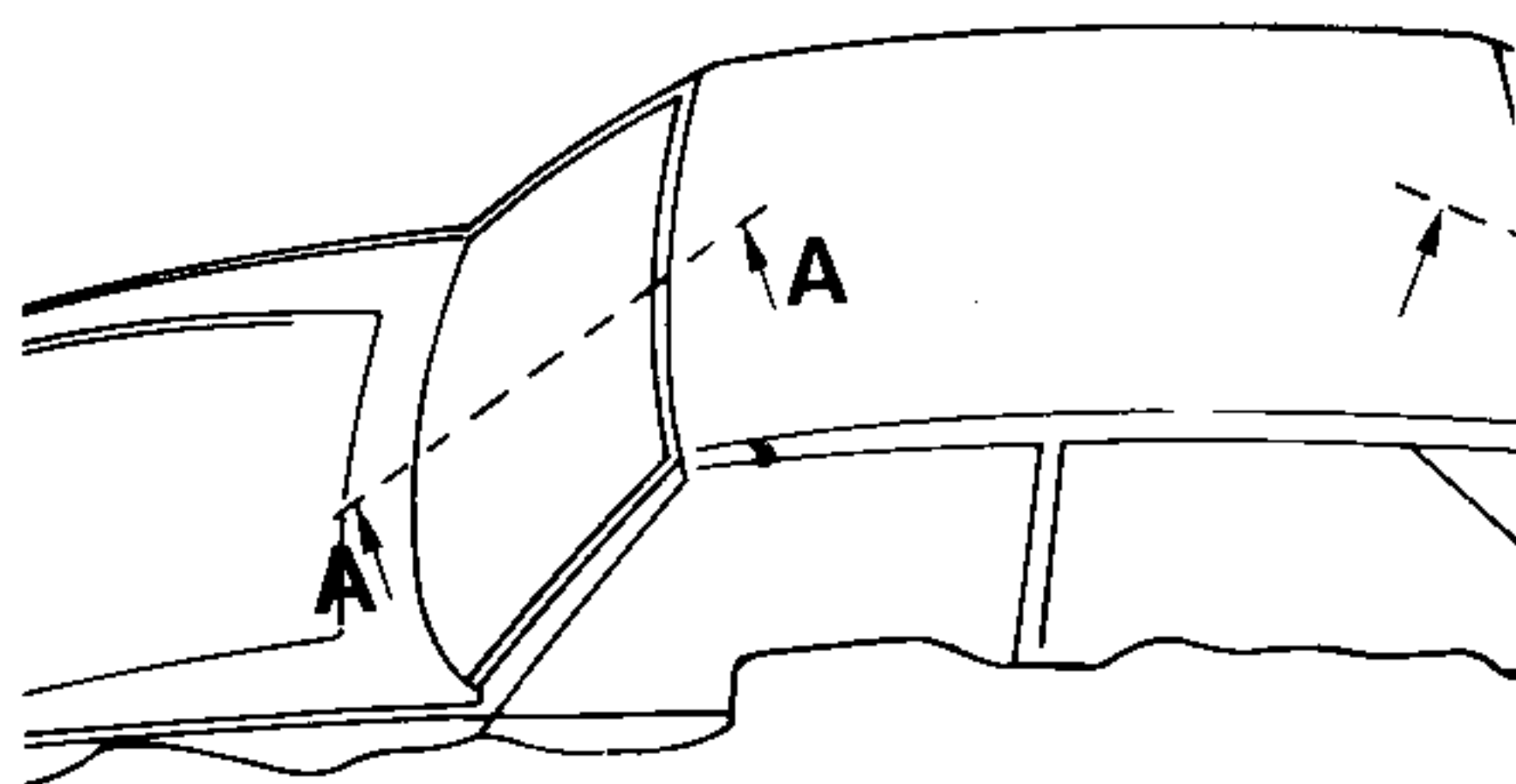
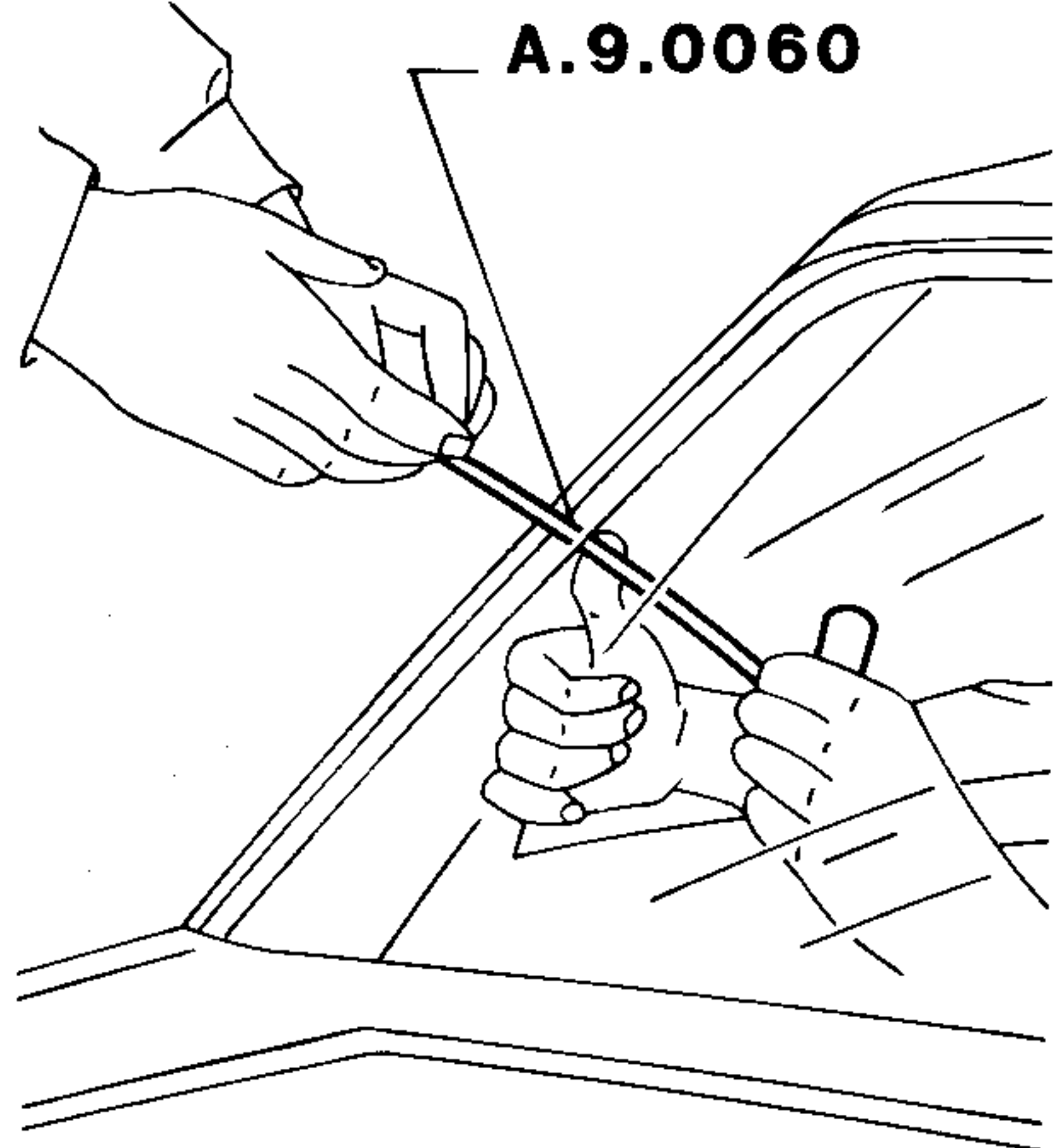

Section A-A

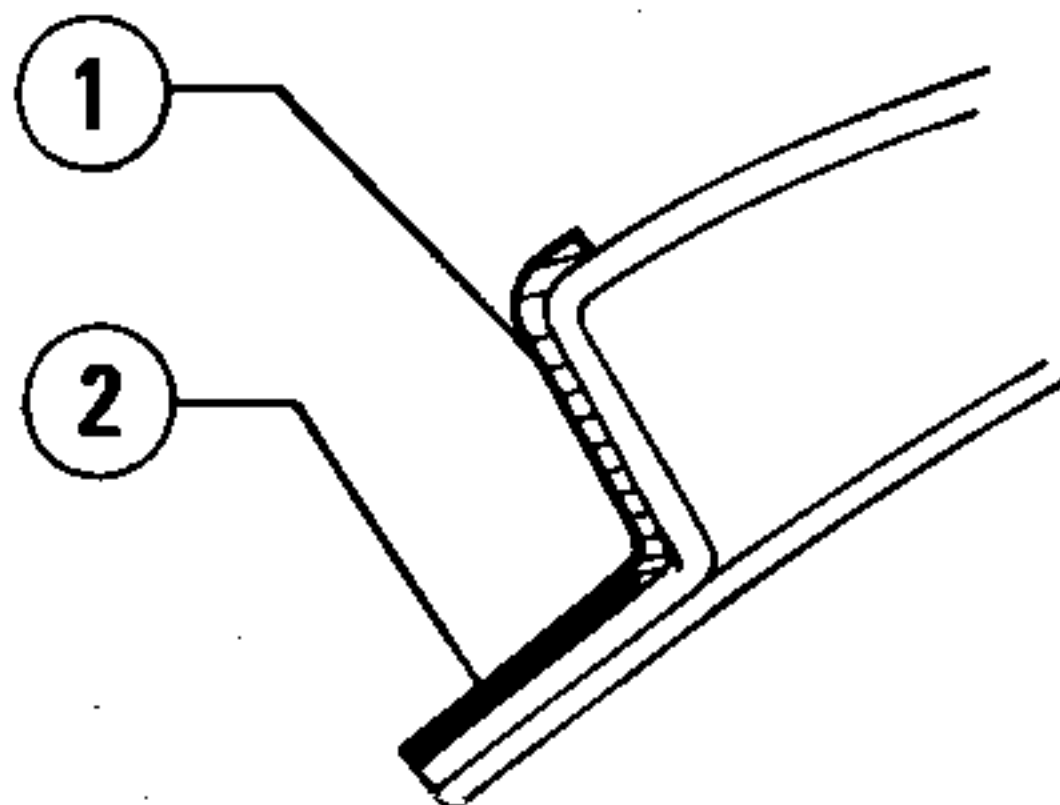

- 1 Adhesive edging
- 2 Levelled glue

INSTALLATION

CAUTION:

- To secure the windscreen to body use the glue kit ALFA ROMEO Std. No. 162.00.76.001.99.
- Open the kit only when it is to be used.
- Follow the use rules shown on the kit.

1. Carefully smooth the old glue in order to level the surface on the windscreen rim seat.

2. Use a dry cloth or a jet of compressed air to remove the glue particles removed as a consequence of the previous operation.

Do not use alcohol or alcohol-based compounds.

3. If the sheet panel is exposed in a few points, apply the sheet protective primer first, and after it has dried, apply the sheet primer contained in the glue kit. Take care to apply the primer only on the exposed points.

4. Apply the adhesive edging (1) on the upper edge of windscreen rim shown in the figure.

New windscreen

5a. Clean the windscreen edge using the degreaser contained in the glue kit taking care not to leave prints on the surface concerned in the glueing.

Old windscreen

5b. Level the glue remained on the windscreen, and remove the residuous of working.

New windscreen

6a. Apply the glue seal (1) on the along the windscreen perimeter at a distance of 12 mm (0.47 in) approx from the edge.

Old windscreen

6b. Apply the glue seal by arranging it as shown in the following figure.

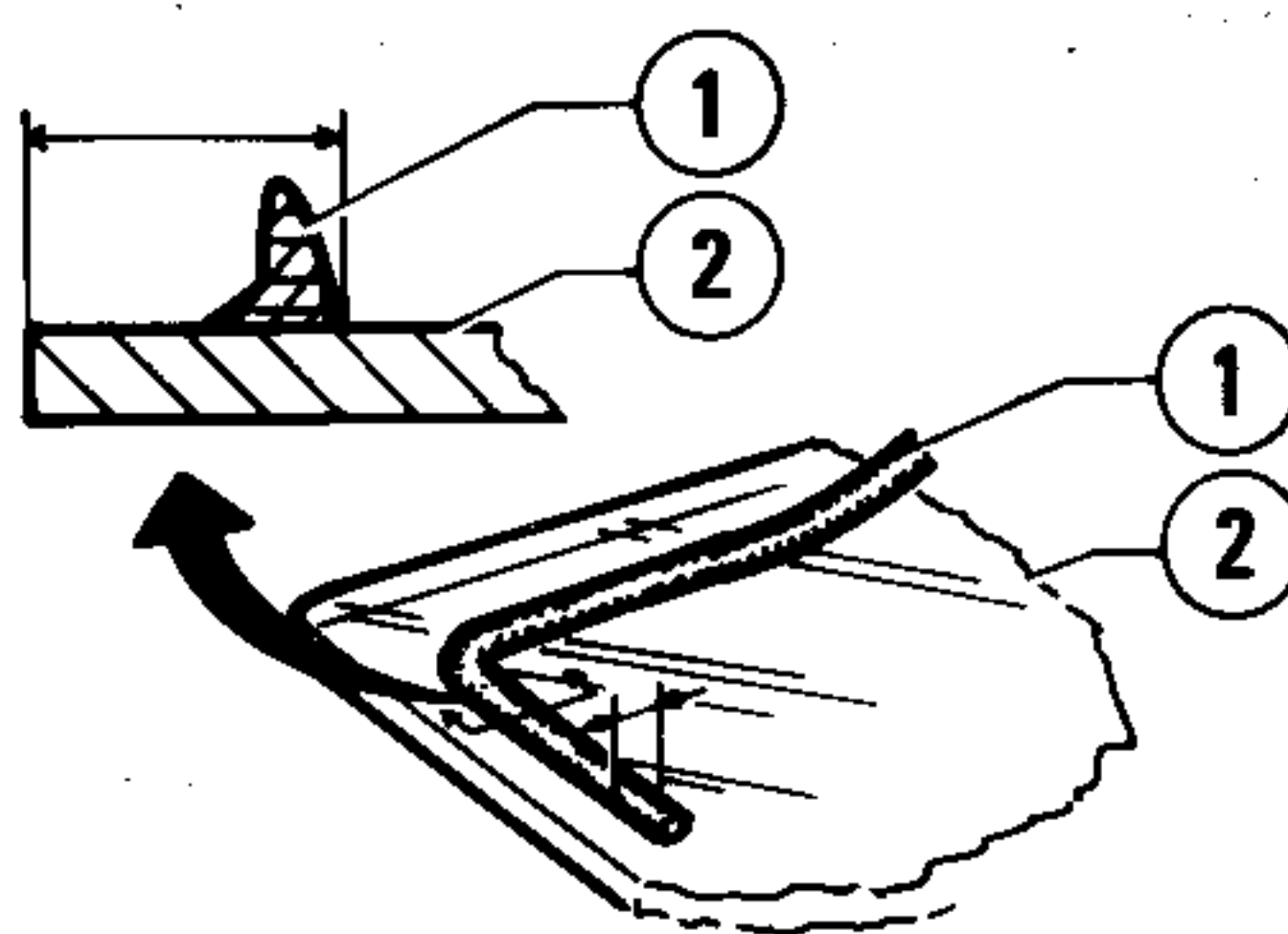

- 1 Glue seal
- 2 Windscreen

New windscreen

7a. Apply the windscreen primer contained in the glue kit on the windscreen area shown in the figure.

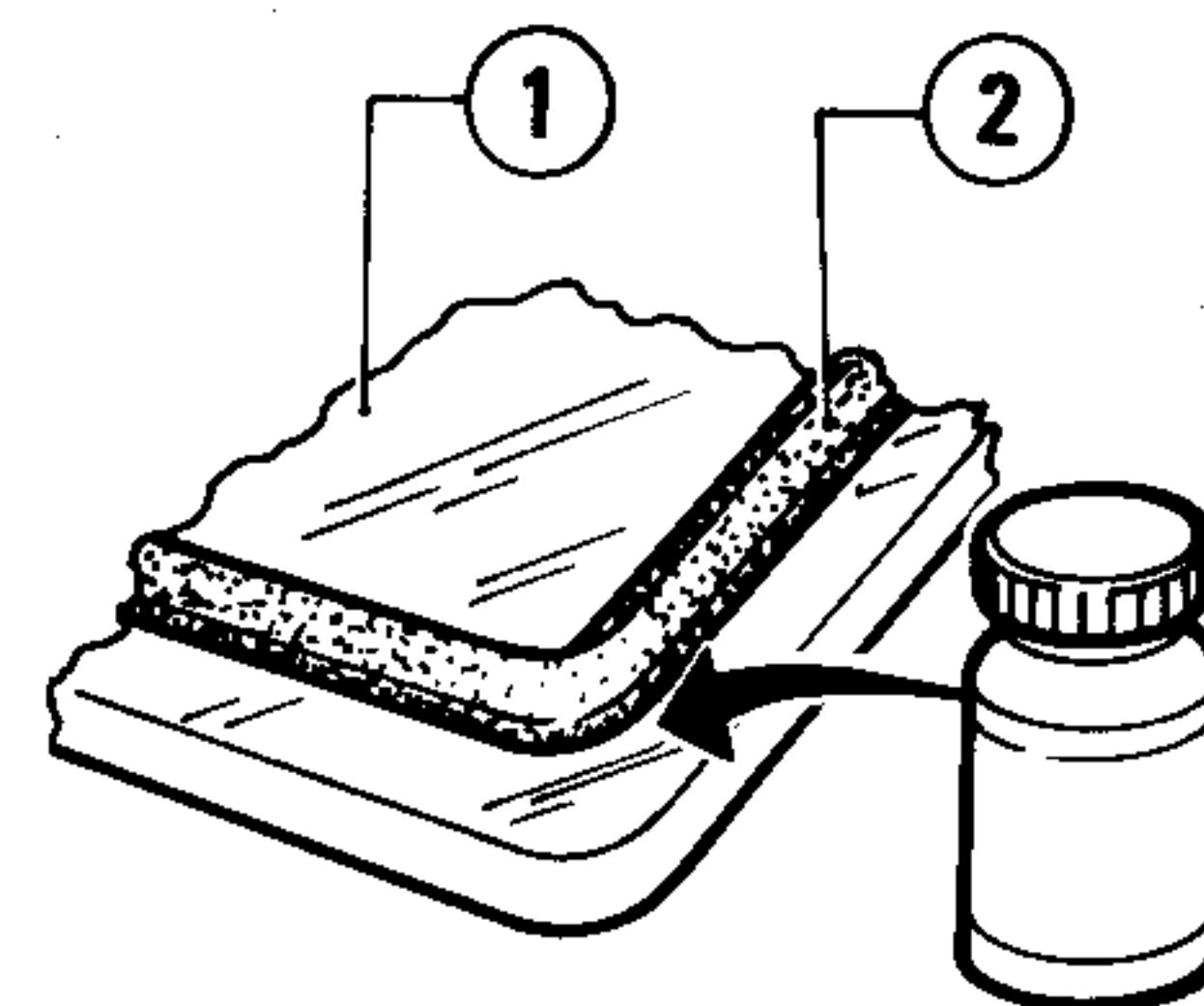

- 1 Windscreen
- 2 Glue seal

Old windscreen

7b. Apply the windscreen primer only on the areas where the windscreen has been exposed during the previous glue levelling operation.

CAUTION:

Before proceeding, allow the product to dry completely.

8. Apply glue (1) on the windscreen edge, as shown in the figure.

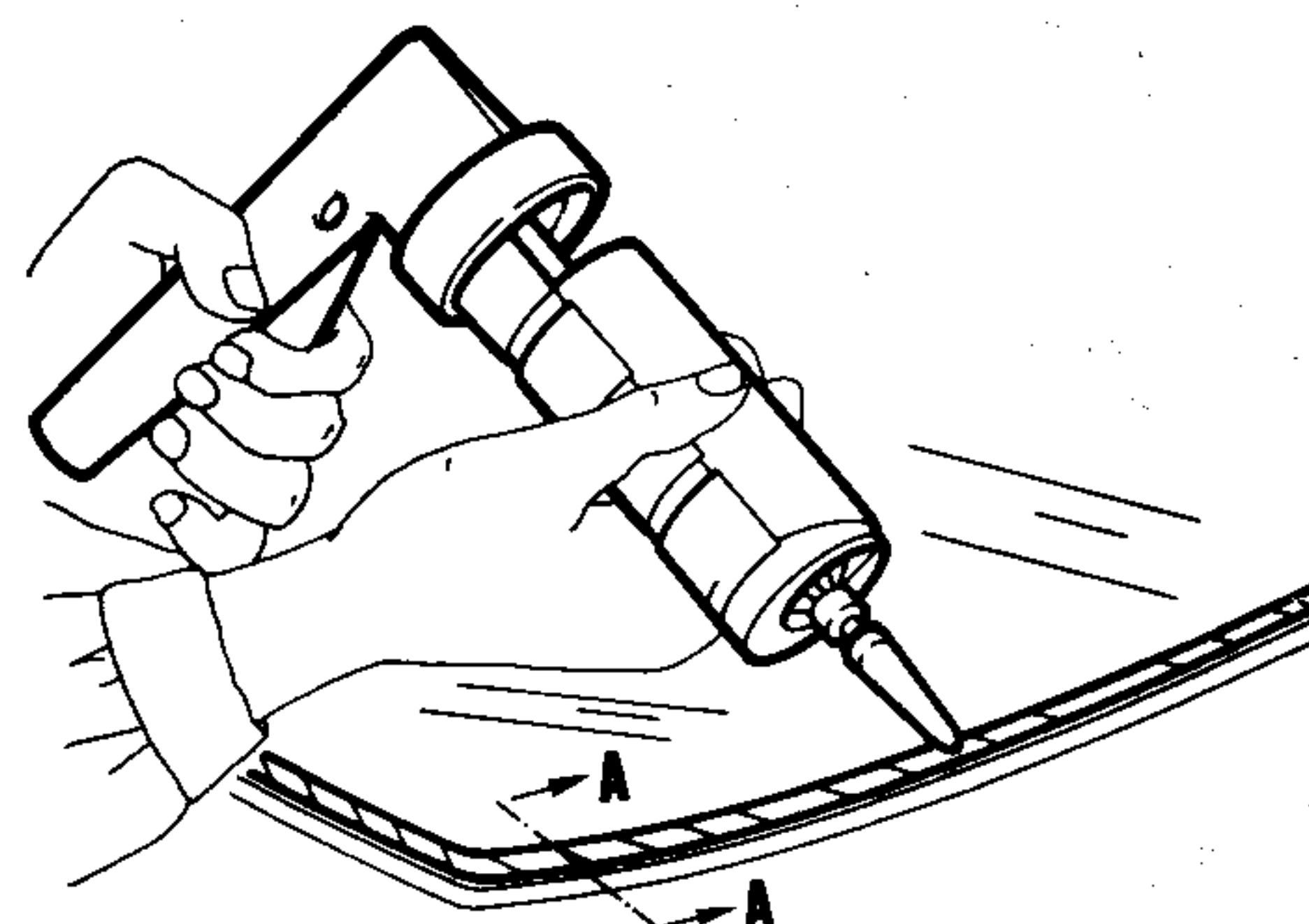

Section A-A

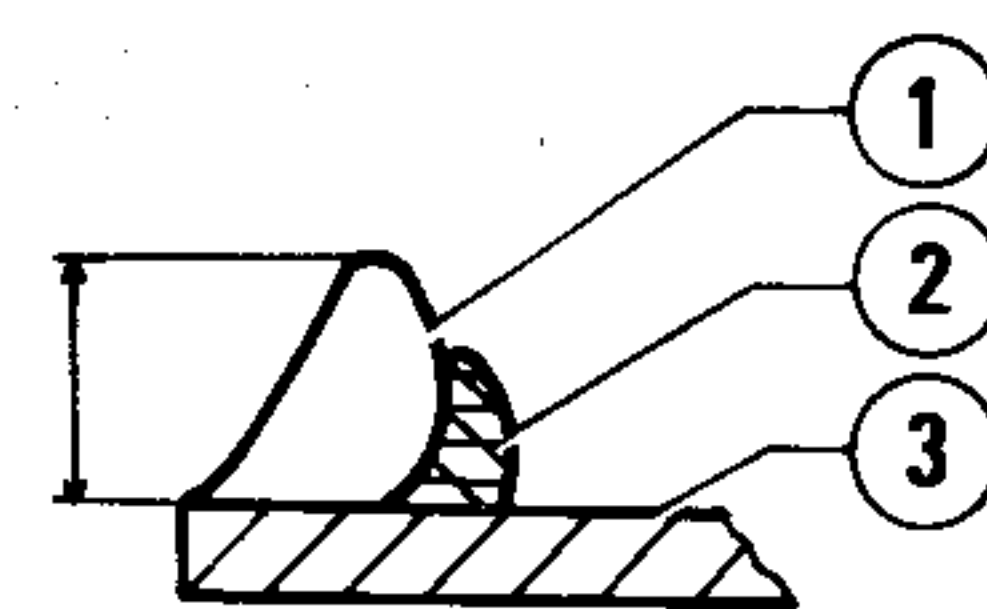

- 1 Silicone sealing compound
- 2 Glue seal
- 3 Windscreen

9. Place three support spacers supplied with the glue kit at the windscreen rim base.

10. Use suction cups to carefully position the windscreen into its seat by pressing slightly and uniformly along the windscreen edge.

EXTERNAL TRIMMING

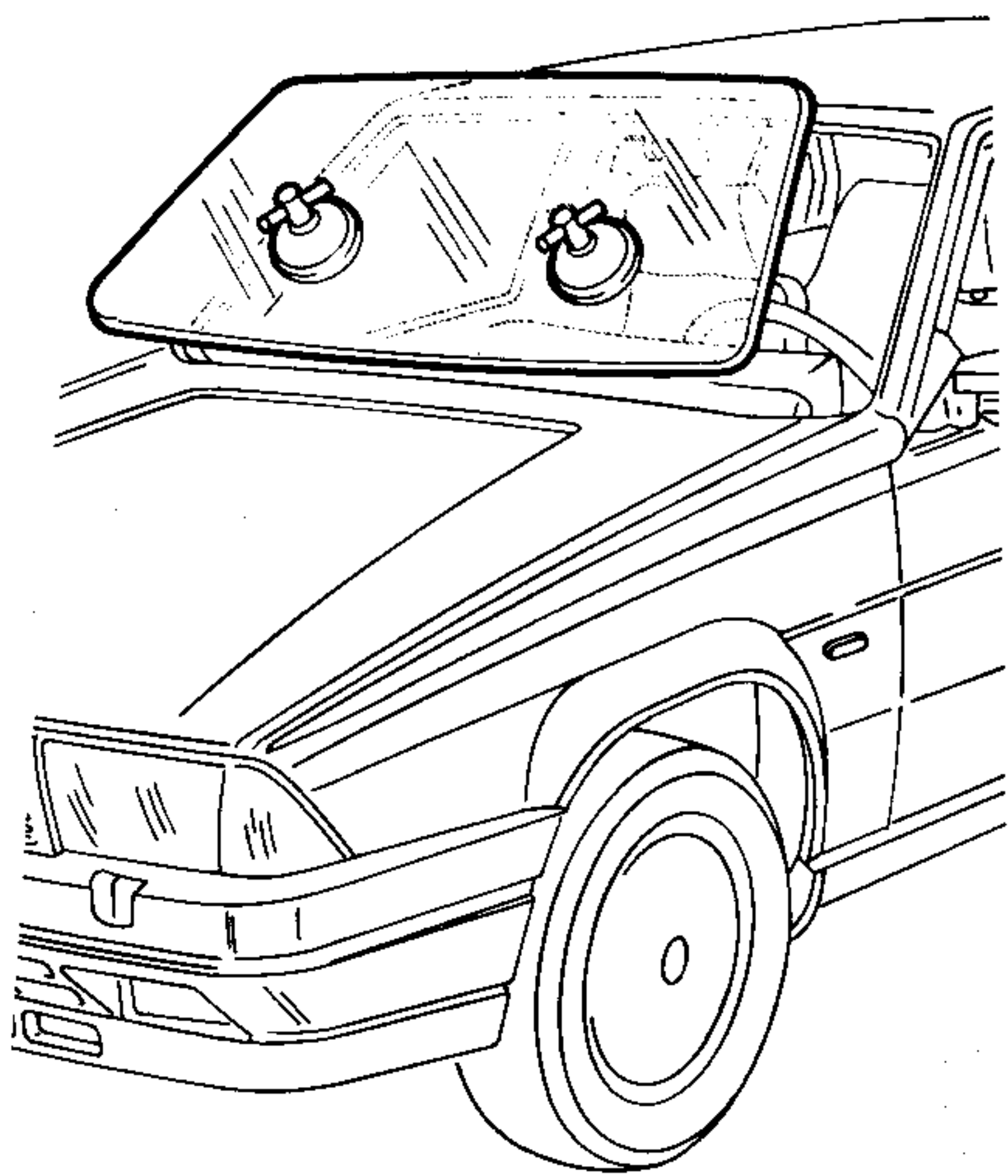

11. Apply the outer weatherstrip before the glue has dried.

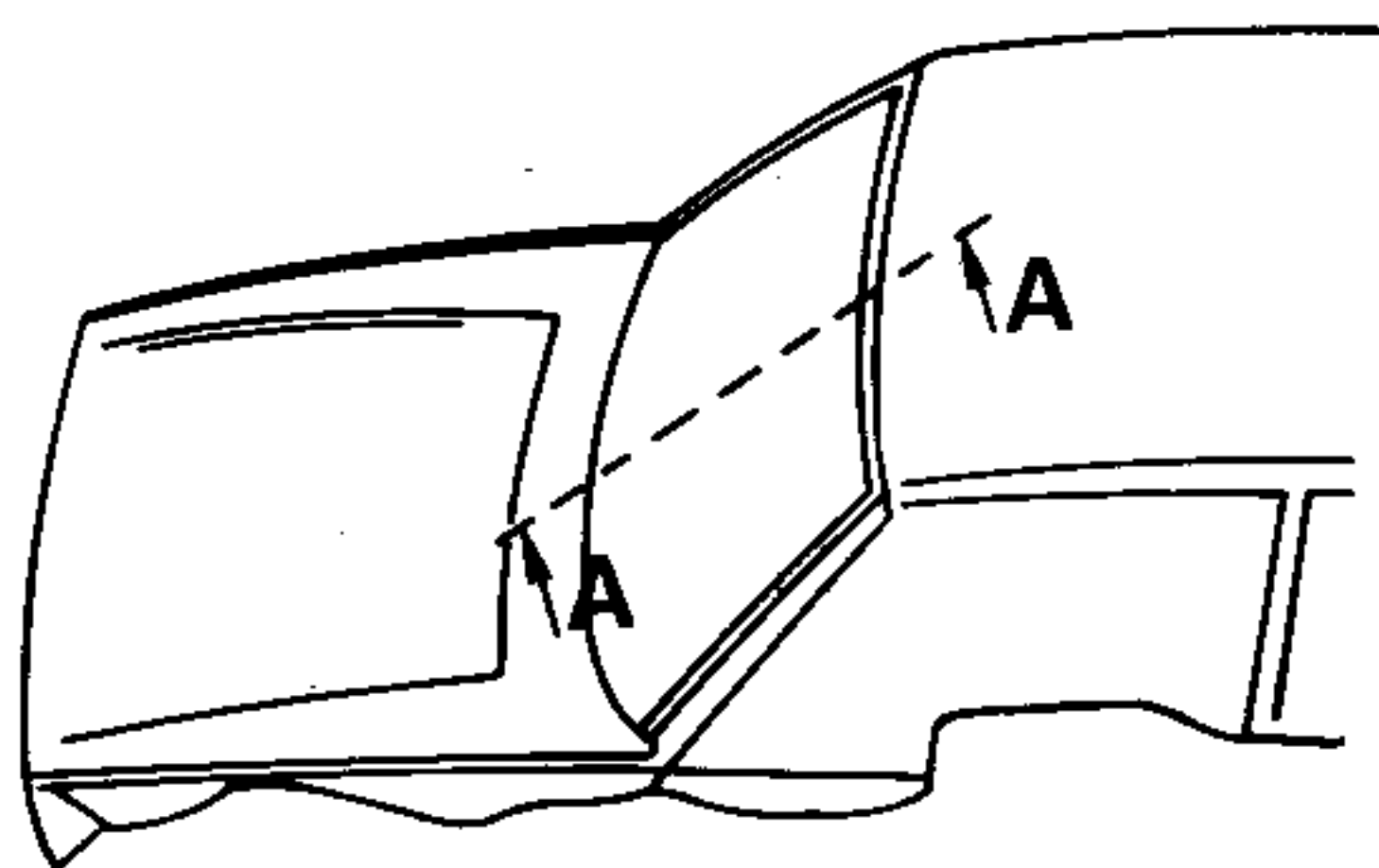

Section A-A

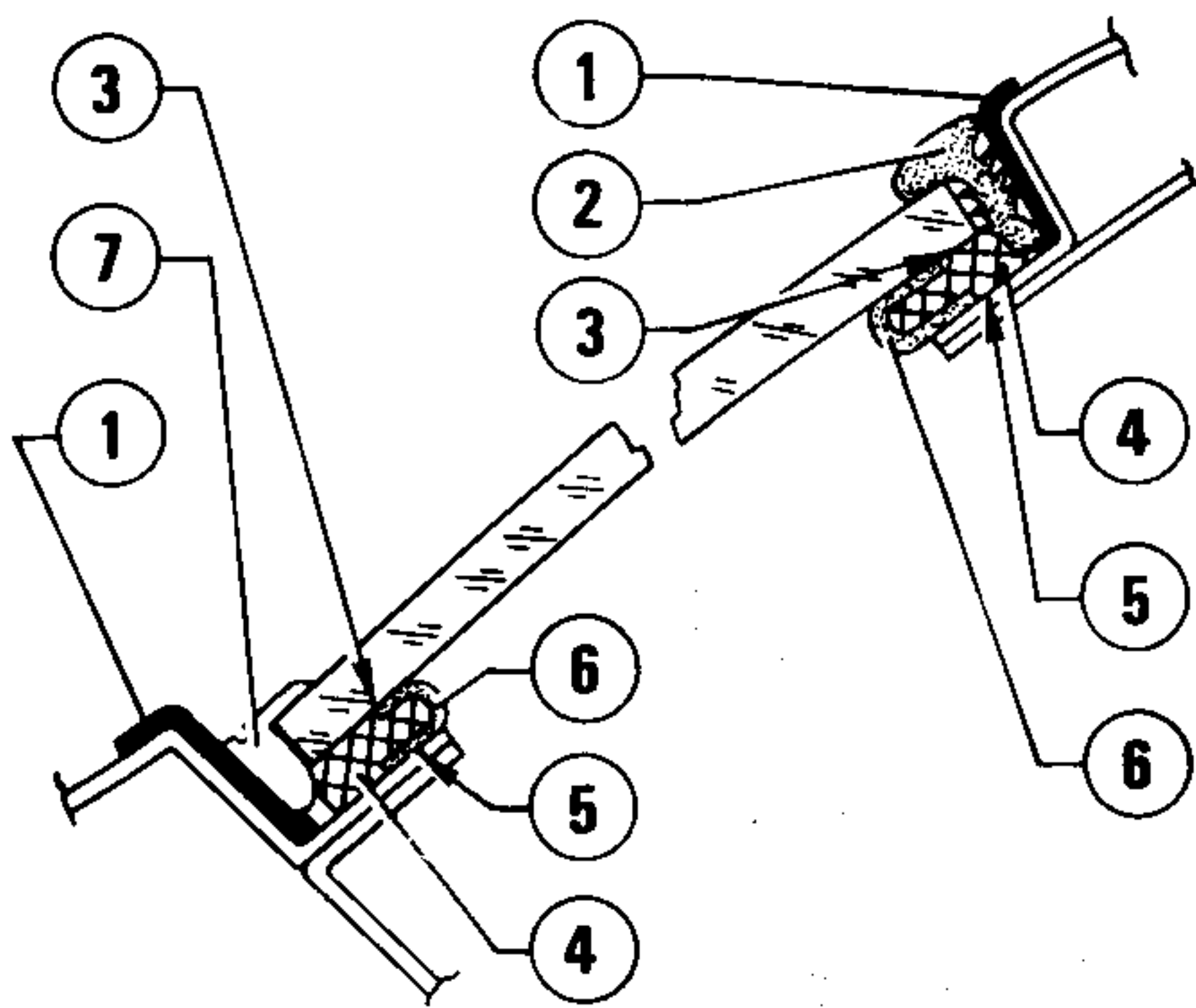

- 1 Adhesive edging
- 2 Outer weatherstrip
- 3 Window primer
- 4 Glue
- 5 Body primer
- 6 Glue seal
- 7 Windscreen lower spacer

12. Do not use the vehicle for at least **12 hours**; then perform the water leaks test by operating as follows.

- Use the shampoo of the type approved ALFA ROMEO (Std. No. **100.0092.000.01**), and create a remarkable quantity of foam.
- By means of a brush, apply the foam all along the window outer perimeter.
- Blow compressed air from the passenger compartment inside, and check for bubbles. If bubbles are present, proceed as indicated in "Elimination of Leaks".

13. Refit trims and finishings that have been removed during windscreen removal.

6. Complete the assembly, and after **12 hours** repeat the test given in "Windscreen - Installation" step 12.

Glue to remove

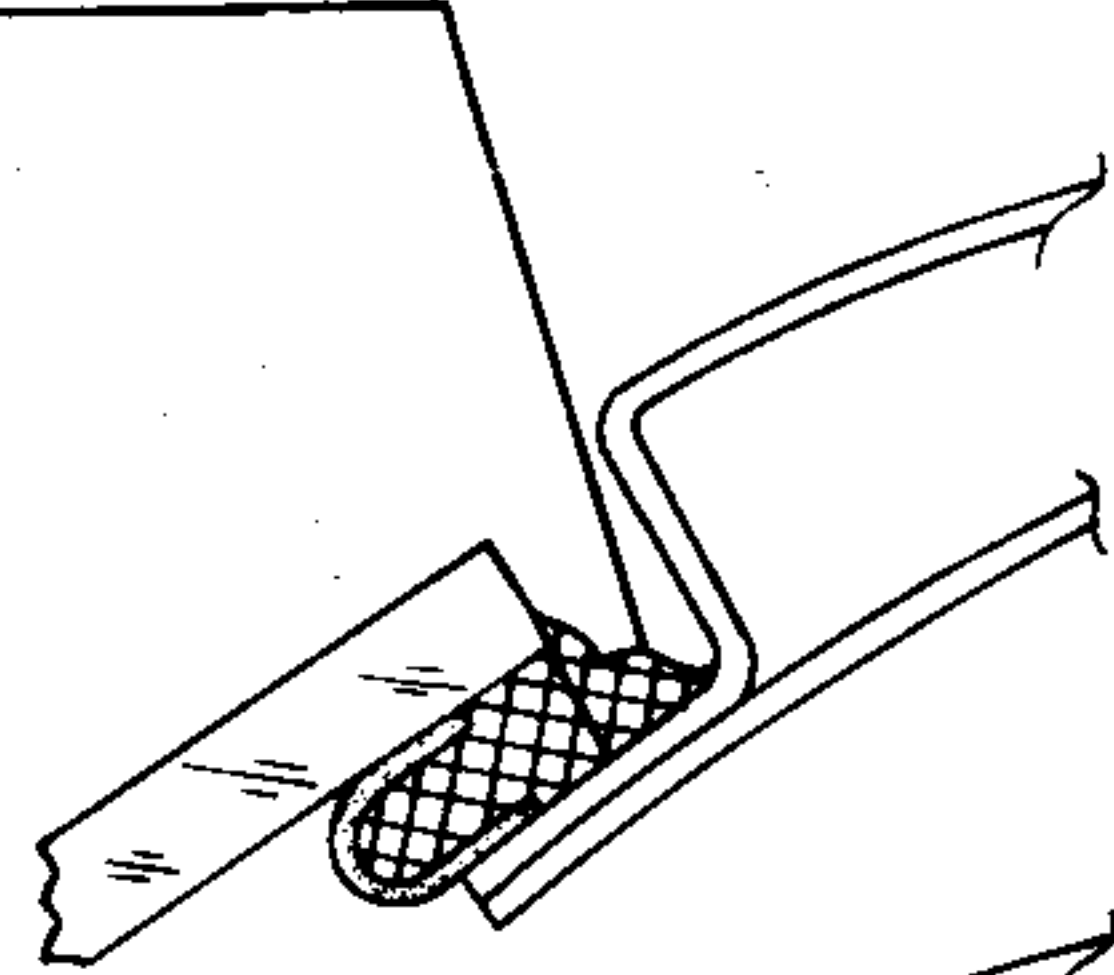

Apply primer

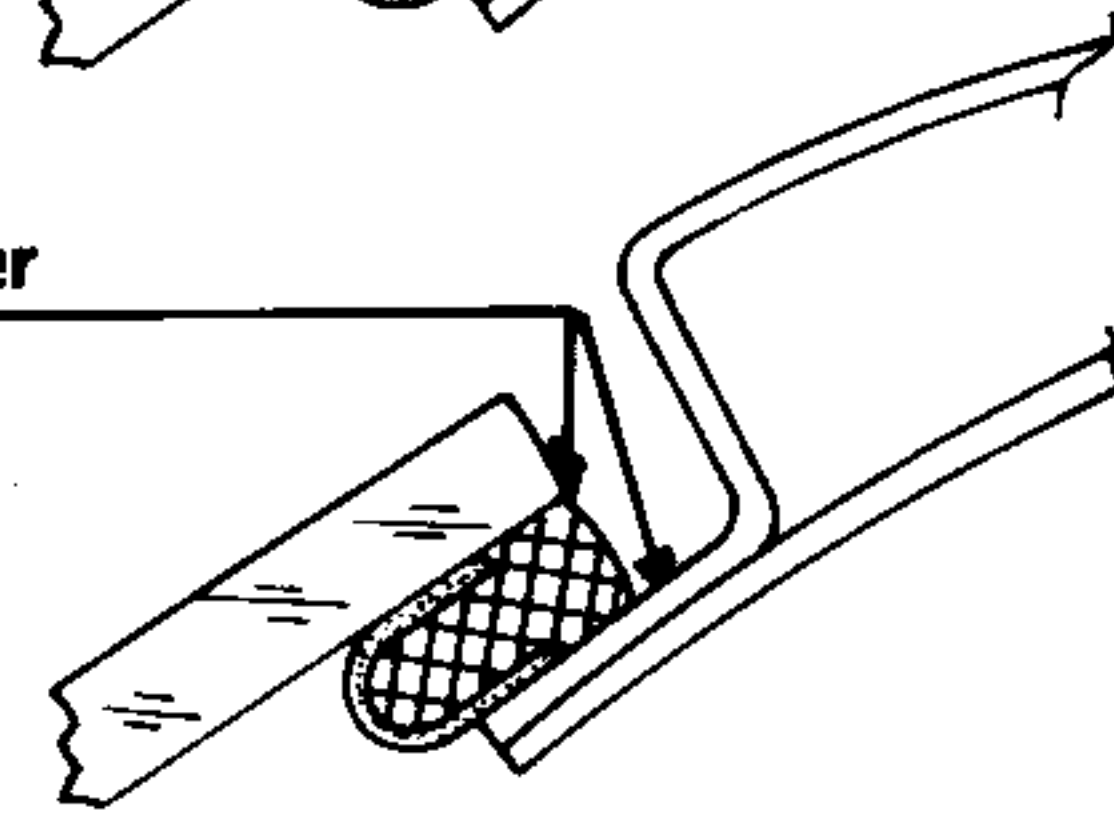

Apply glue

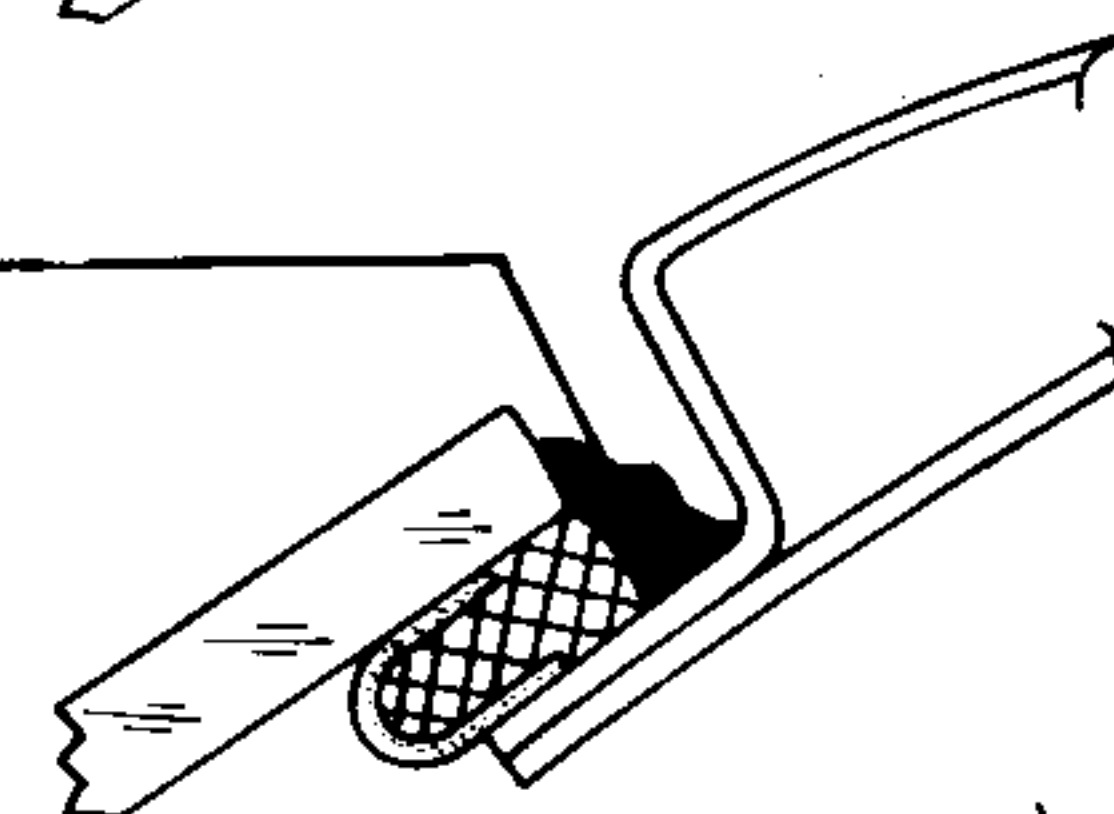

Spatula

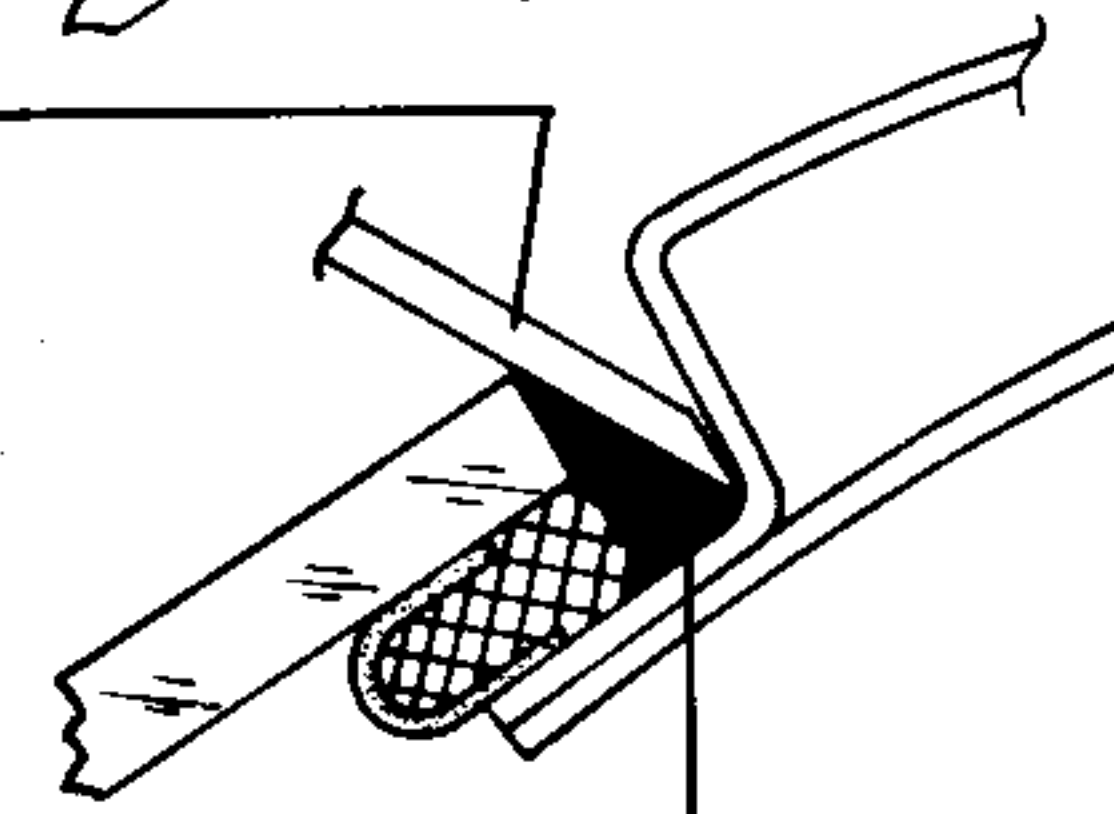

Glue to push between gaps

ELIMINATION OF LEAKS

To eliminate leaks without having to remove the window, proceed as follows.

1. Remove the seal in the leaking area.
2. To discover the extent of the leak (which can occur between body and glue, or between glue and window) push the window outwards and pour water on the leaking area.
3. Remove the old glue taking care not to scratch the sheet panel underneath.
4. Apply the window primer on the leaking area.
5. After the primer has dried completely, push the new glue into the gap using a plastic spatule as shown in the figure.

WINDOW FRAME SHEET PANEL REPLACEMENT

In the event of partial or complete replacement of window frame, comply with the following procedure:

1. Apply the primer and the paint (selected both among the products of ALFA ROMEO approved suppliers) so as to restore sheet panel protection.
2. Apply the sheet panel primer contained in the kit, on the window seat. Install the window by following the related procedure.

EXTERNAL TRIMMING

REAR WINDOW

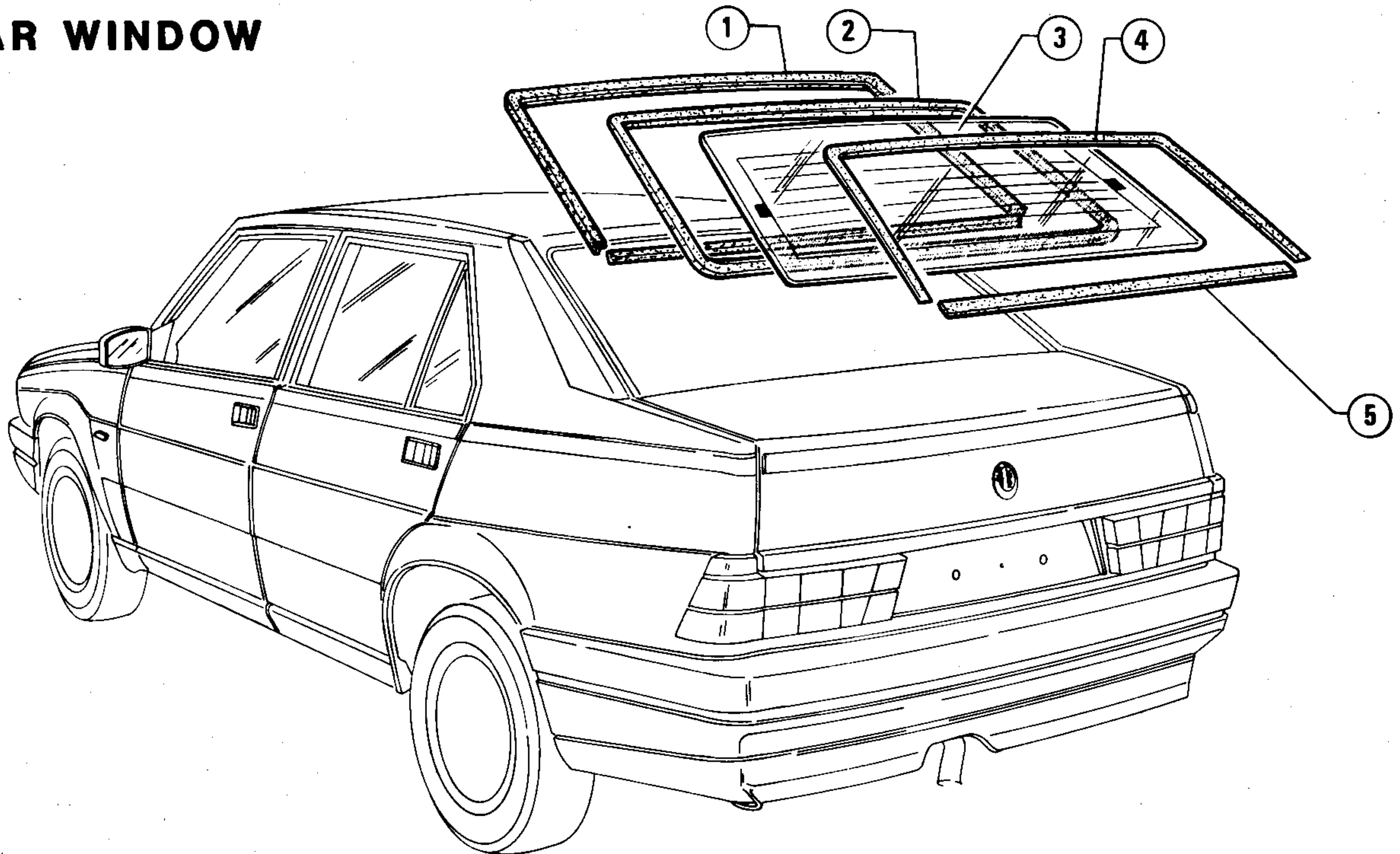

- 1 Adhesive edging
- 2 Glue seal
- 3 Rear window
- 4 Outer weatherstrip
- 5 Rear window finishing lower edging

REMOVAL

1. Disconnect the heated rear window wiring.
2. Remove the internal trims on the pillars (refer to: Group 66 - "Trim of Shelf under Rear Window and Rear Pillars").
3. Remove the outer weatherstrip and the rear window finishing lower edging.
4. To remove the rear window, follow the procedure described in "Windscreen" steps 4. and 5.

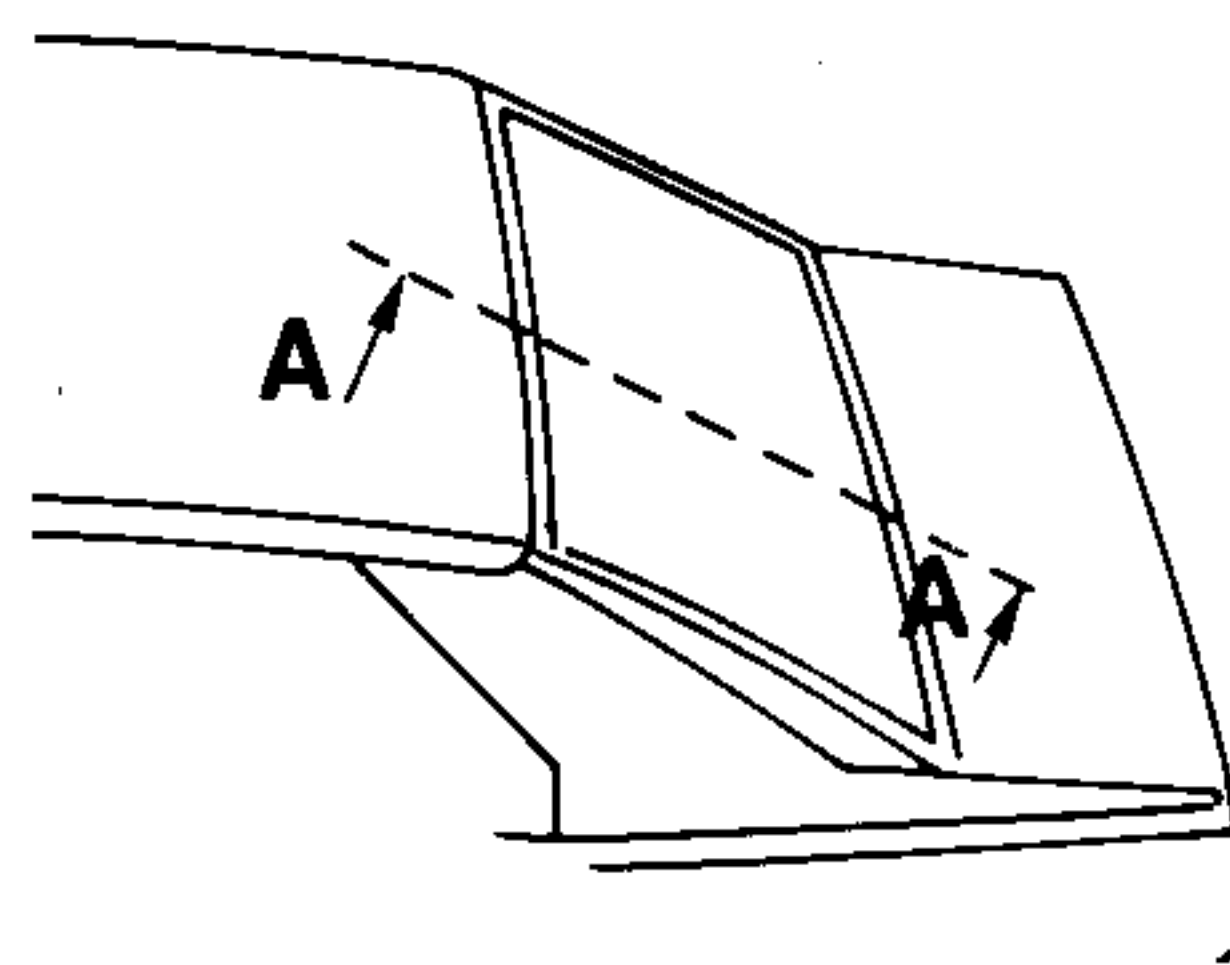

Section A-A

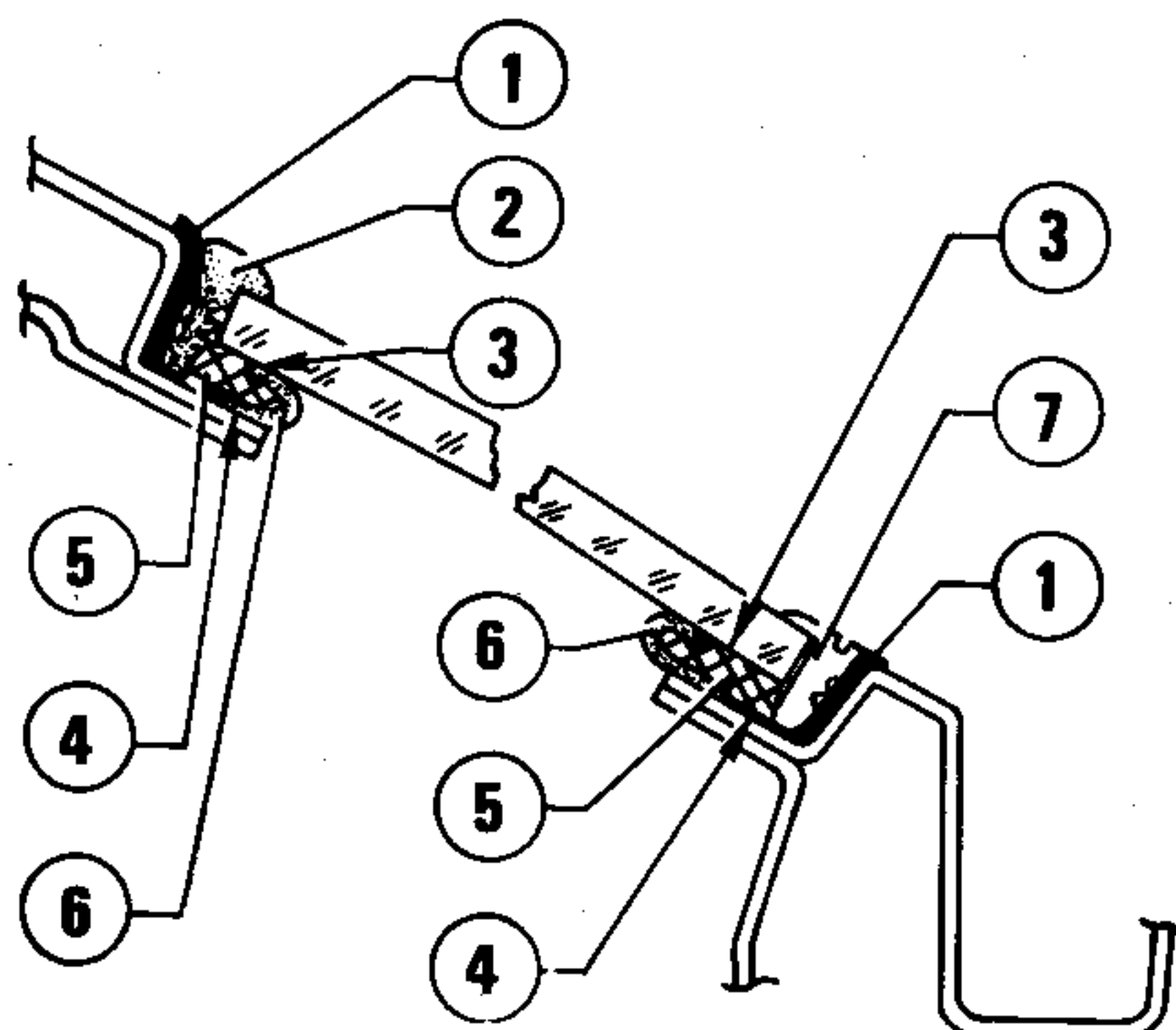

- 1 Adhesive edging
- 2 Outer weatherstrip
- 3 Window primer
- 4 Glue
- 5 Body primer
- 6 Glue seal
- 7 Rear window lower spacer

INSTALLATION

To install the rear window, comply with the procedure given in "Windscreen - Installation".

ELIMINATION OF LEAKS

Refer to: "Windscreen - Elimination of Leaks".

BUMPERS

FRONT BUMPER

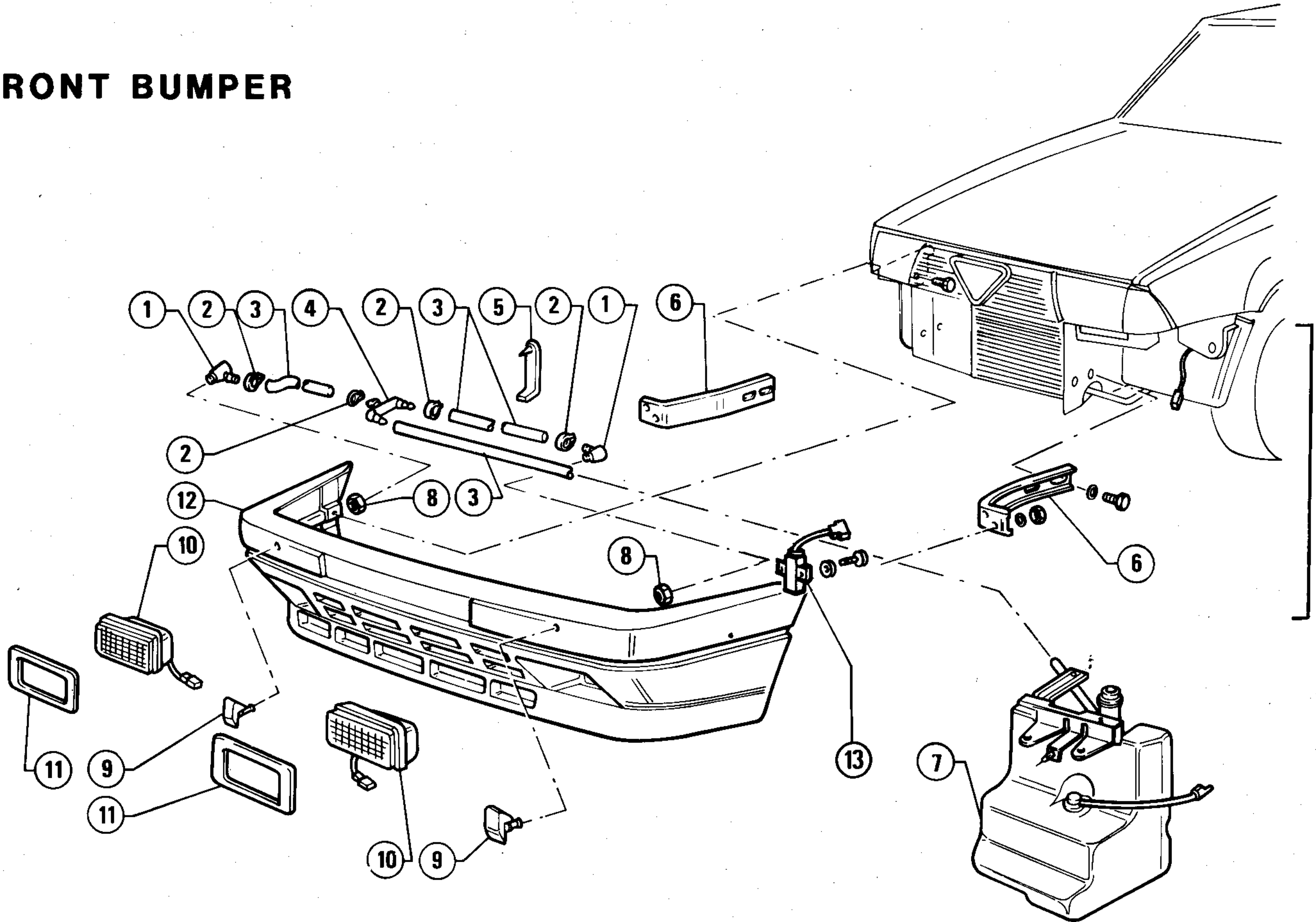

- 1 Union
- 2 Clamp
- 3 Piping
- 4 Union Tee
- 5 Support
- 6 Bracket

- 7 Windscreen washer liquid tank
- 8 Plastic rivet
- 9 Bumper guard with spray nozzles (optional)
- 10 Fog light
- 11 Rim
- 12 Bumper
- 13 External temperature sensor

REMOVAL AND INSTALLATION

1. Place the vehicle on a lift.
 2. Remove the windscreen washer liquid tank (refer to: Group 40 - "Windscreen/Headlight Washer").

3. If mounted, disconnect the fog light wiring.

4. Detach wiring from external temperature sensor.

5. Unscrew the two screws securing bumper (1) to body.

6. Unscrew the four screws securing brackets (2) to body. Remove bumper.

EXTERNAL TRIMMING

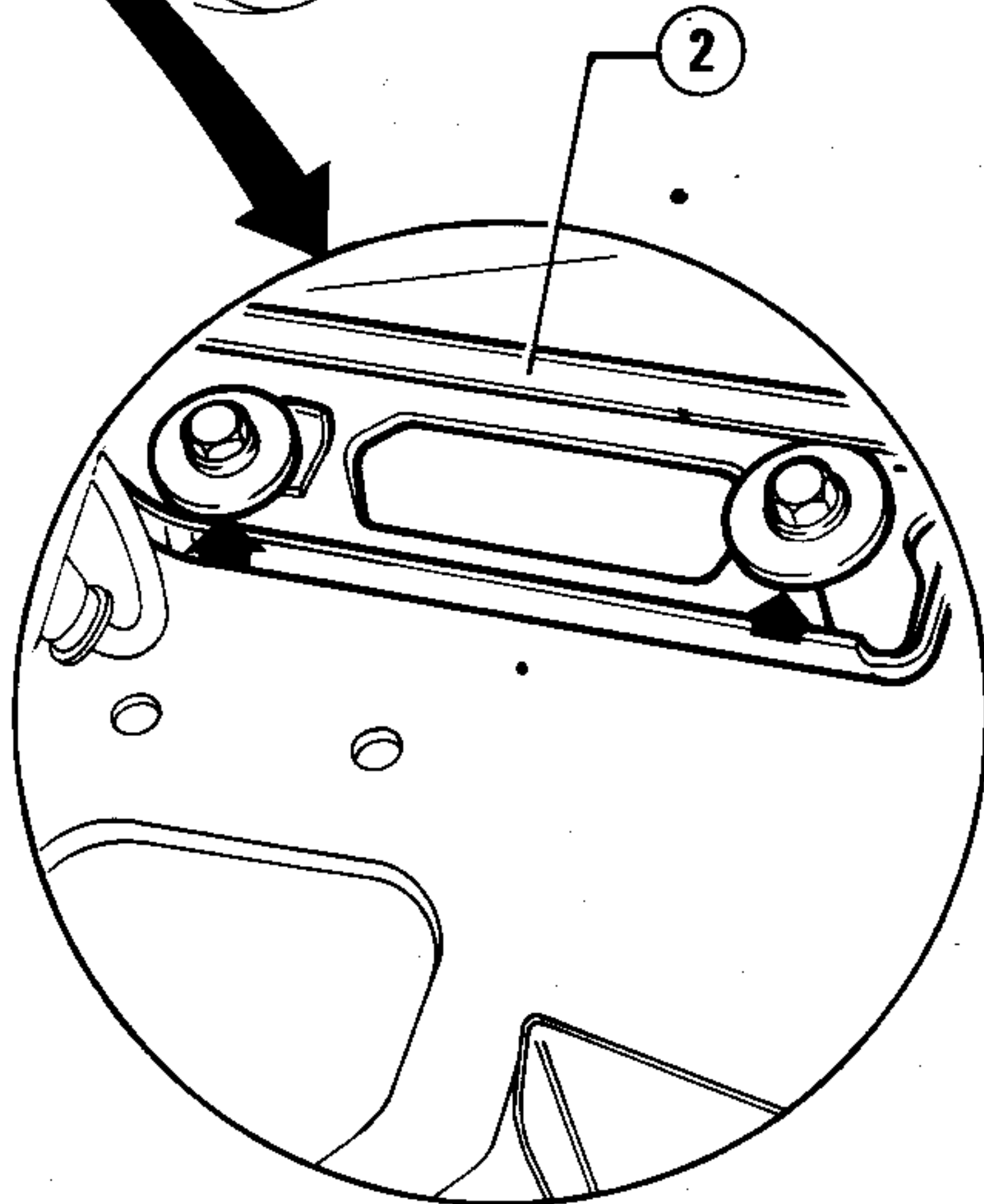
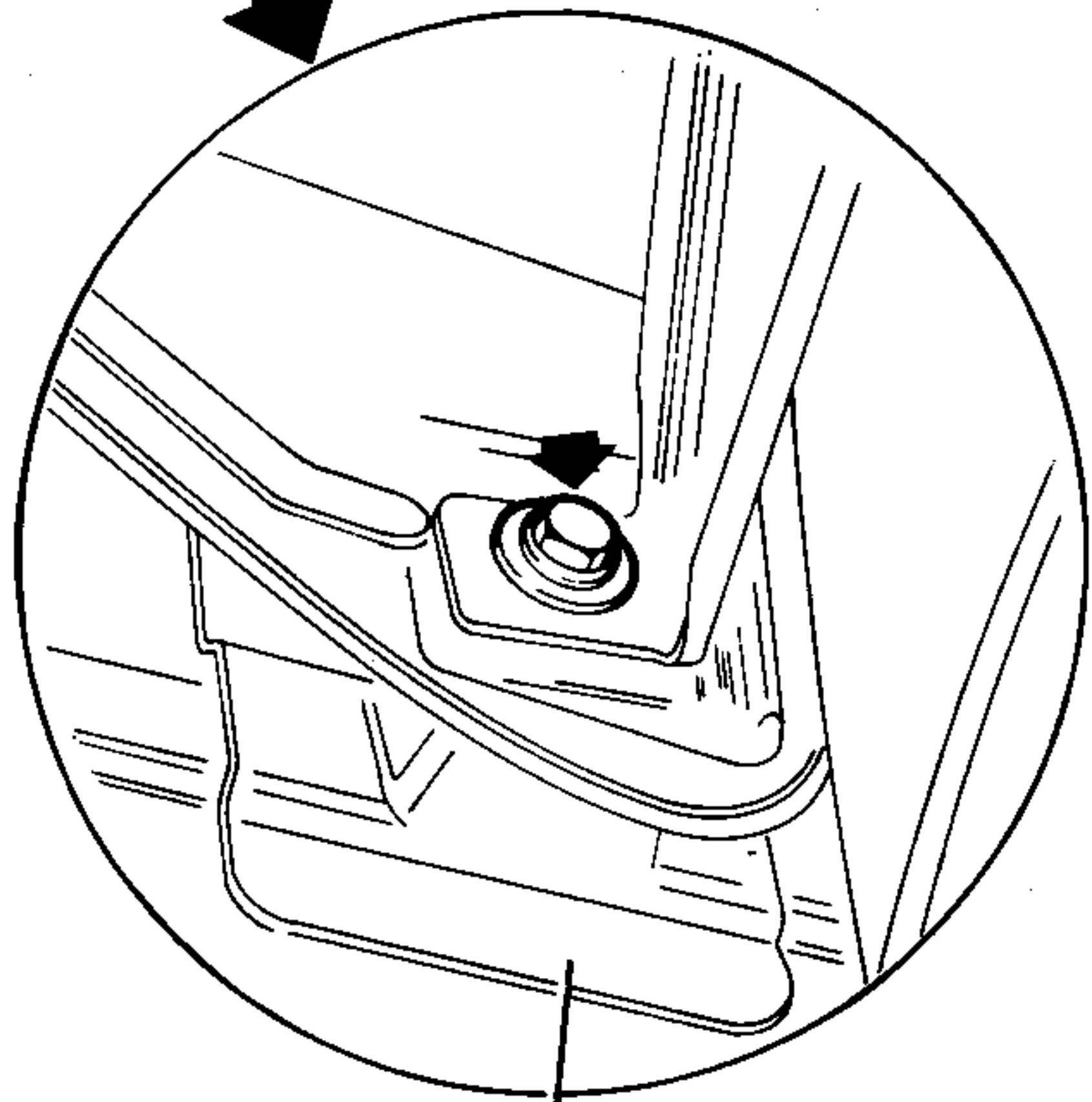
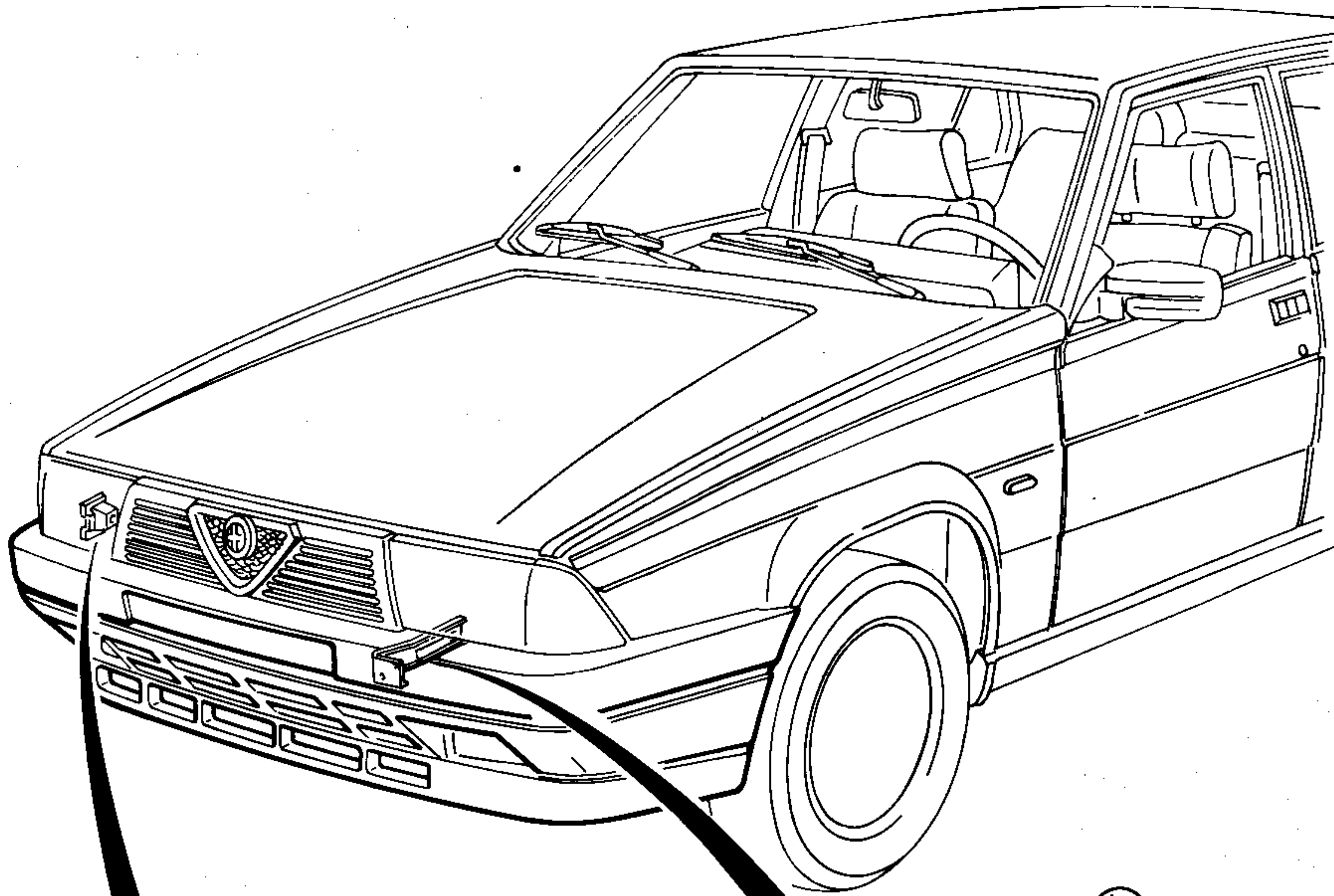

- 1 Bumper
- 2 Bracket

6. If required, to remove the foglights it is necessary to extract the rim and foglights themselves since both have been pushed into place.

7. Models with headlight washers spray nozzles

If necessary, remove bumper guards complete with headlight washer spray nozzles.

a. Detach union (3) from spray nozzle (1) which has been pushed into place.

b. Unscrew nut (2), and remove the guard from bumper.

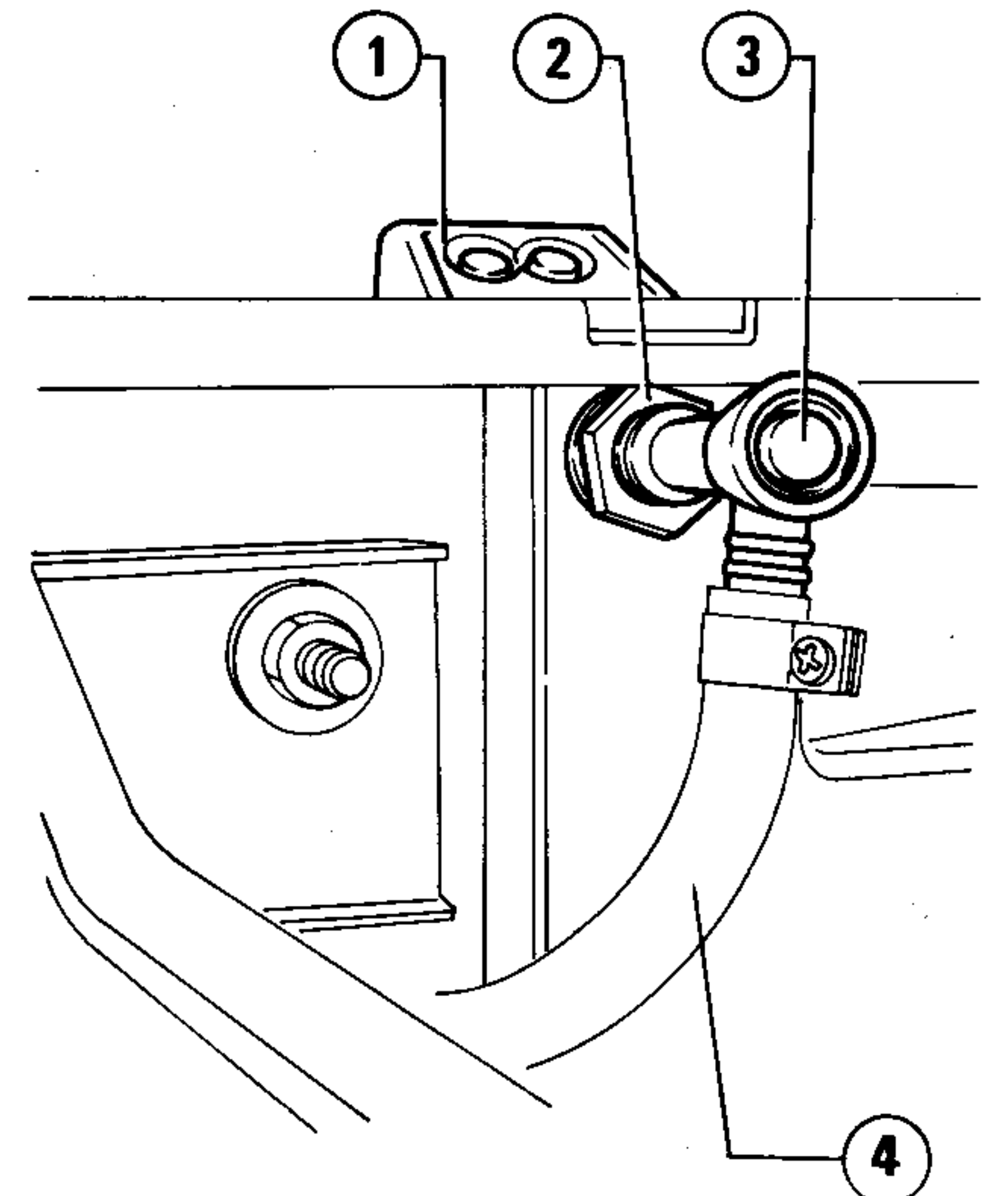

- 1 Bumper guard with spray nozzles
- 2 Plastic nut
- 3 Union
- 4 Piping

8. If necessary, remove protective container of external temperature sensor (refer to: Group 40 - Trip Computer).

9. Install the bumper by reversing the order of removal.

EXTERNAL TRIMMING

REAR BUMPER

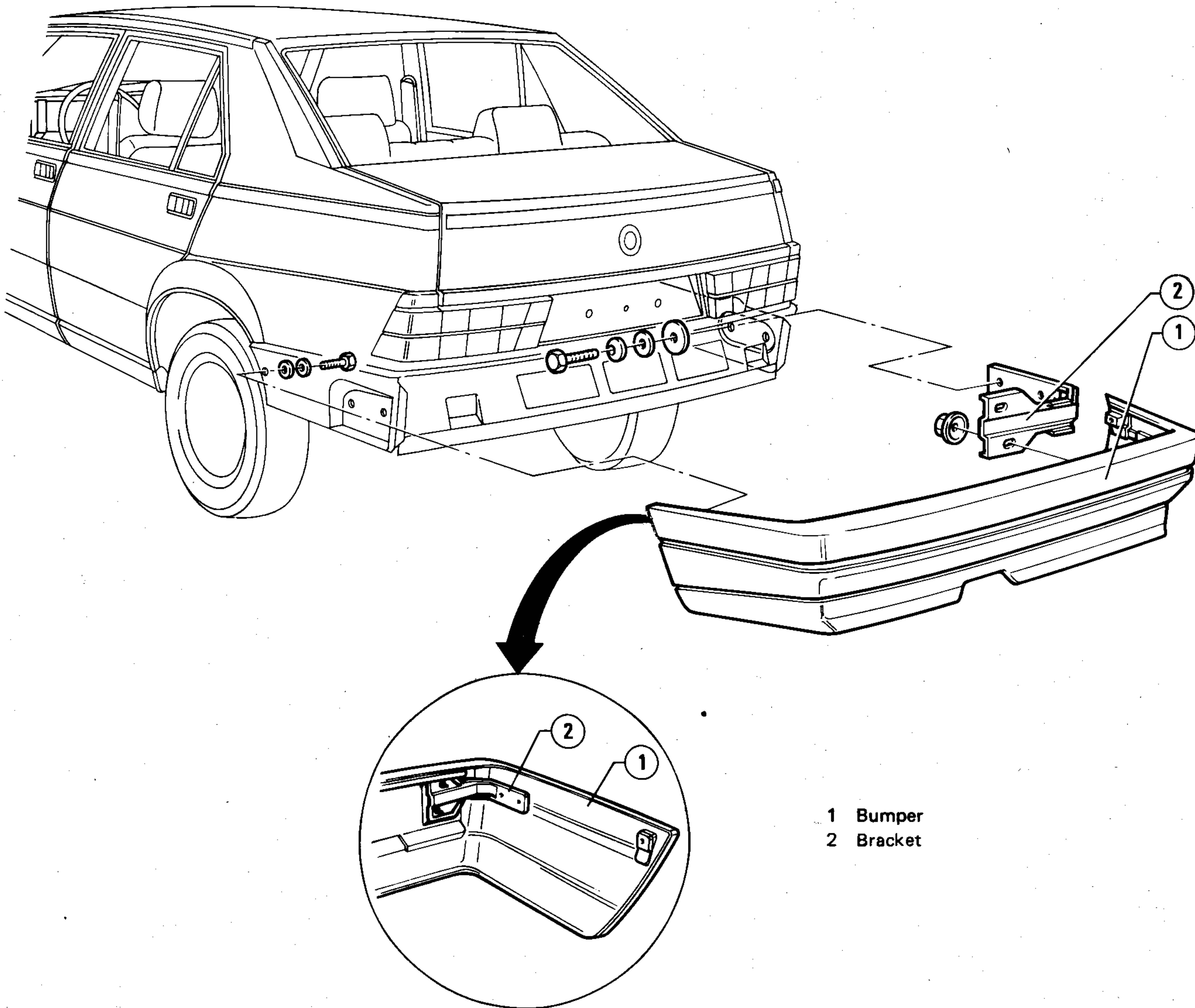

1. Remove the two screws securing the bumper side to body and recover the spacers (1).

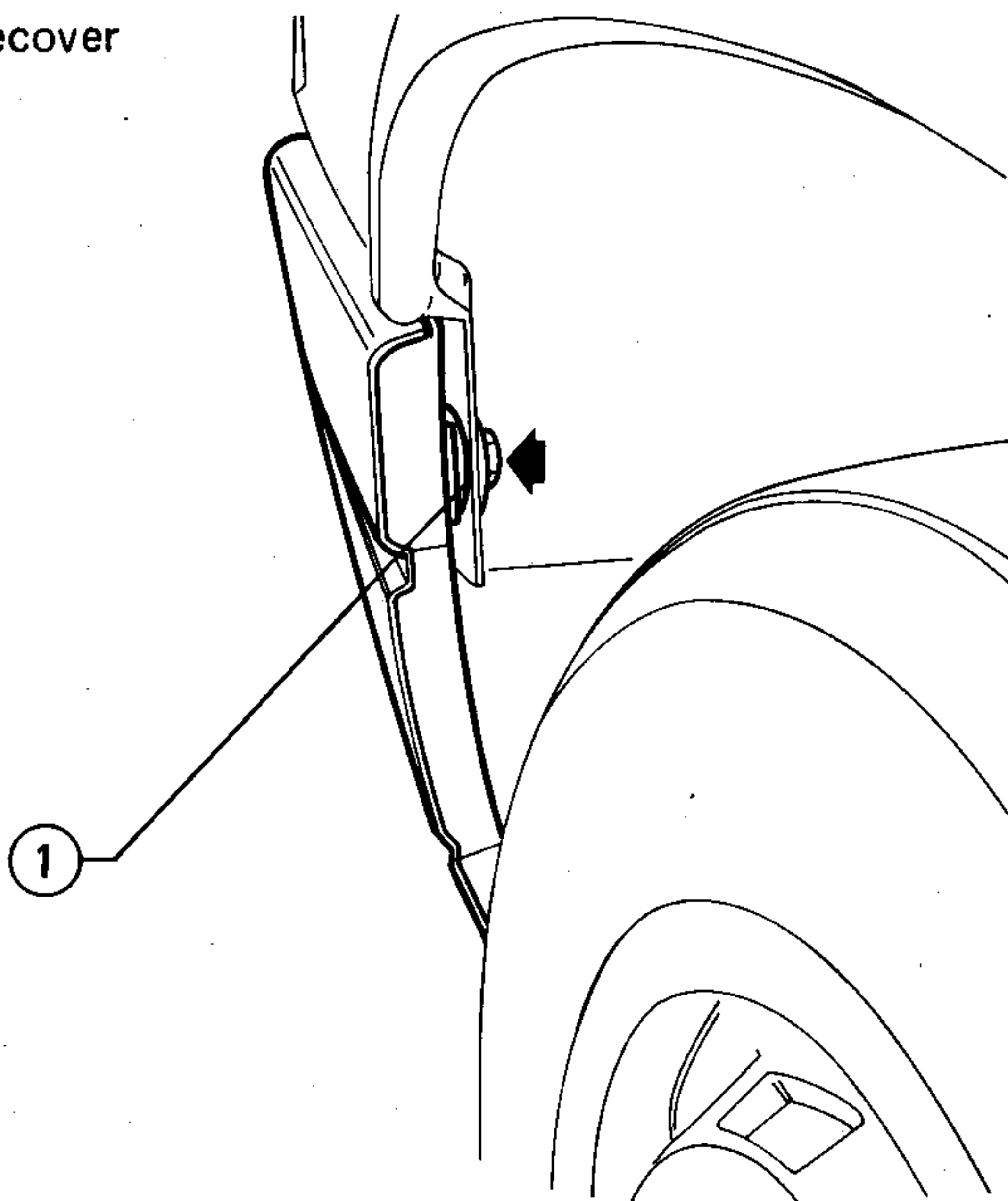

1 Spacer

2. Open the boot lid and lift both rear and side trim.

3. Unscrew the four screws securing bumper to body; remove bumper and recover spacers.

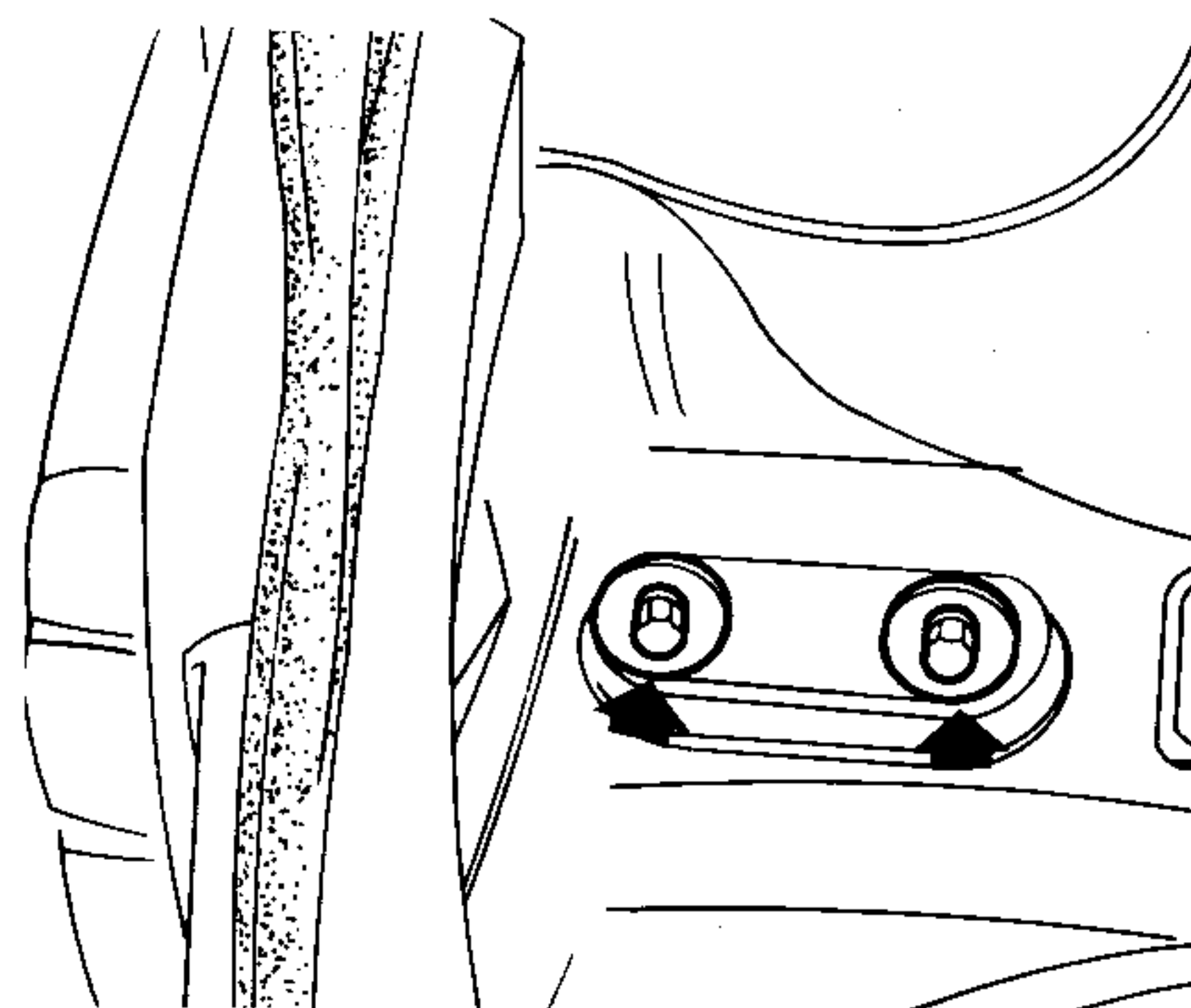

4. Secure bumper to vehicle by reversing the order of removal.

APRON

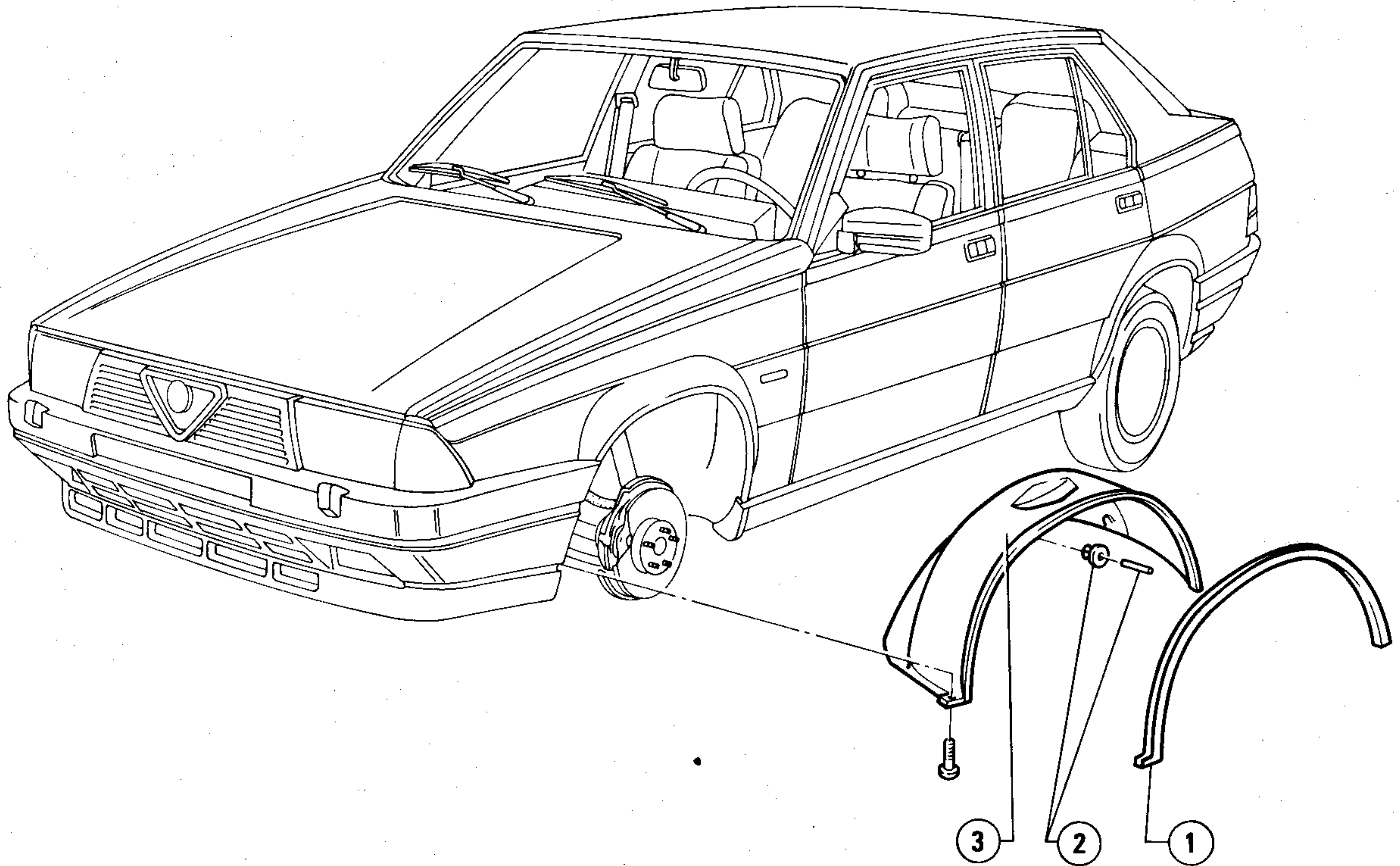

- 1 Edging
- 2 Plastic expansion rivet
- 3 Apron

REMOVAL AND INSTALLATION

1. Remove the wheel and place the vehicle on safety stands (refer to: Group 00 - "Lifting and Towing Points").
2. With the aid of a punch, remove the pins of the four expansion rivets securing apron to body.

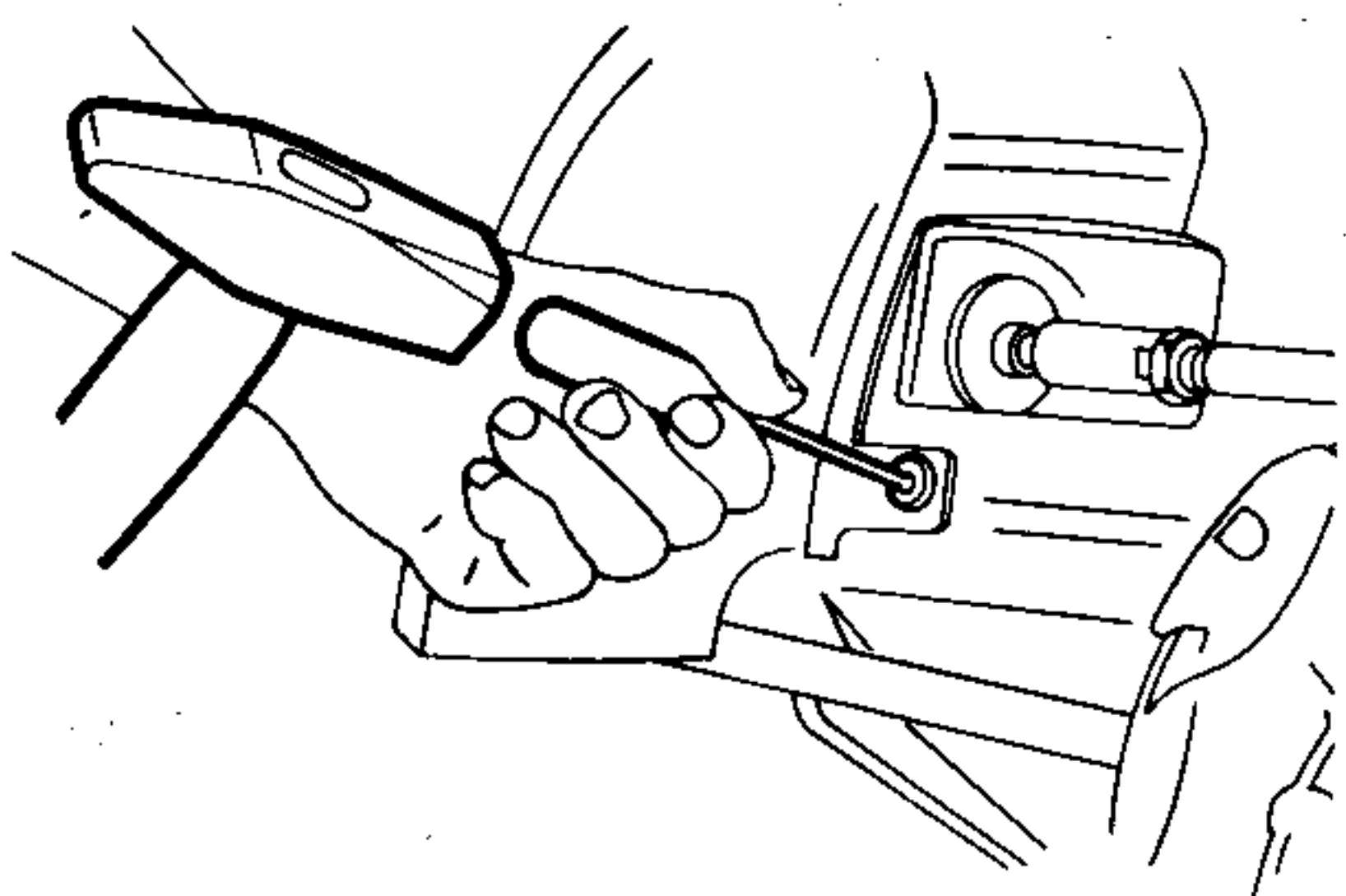

3. Use a suitable tool to remove the four expansion rivets.

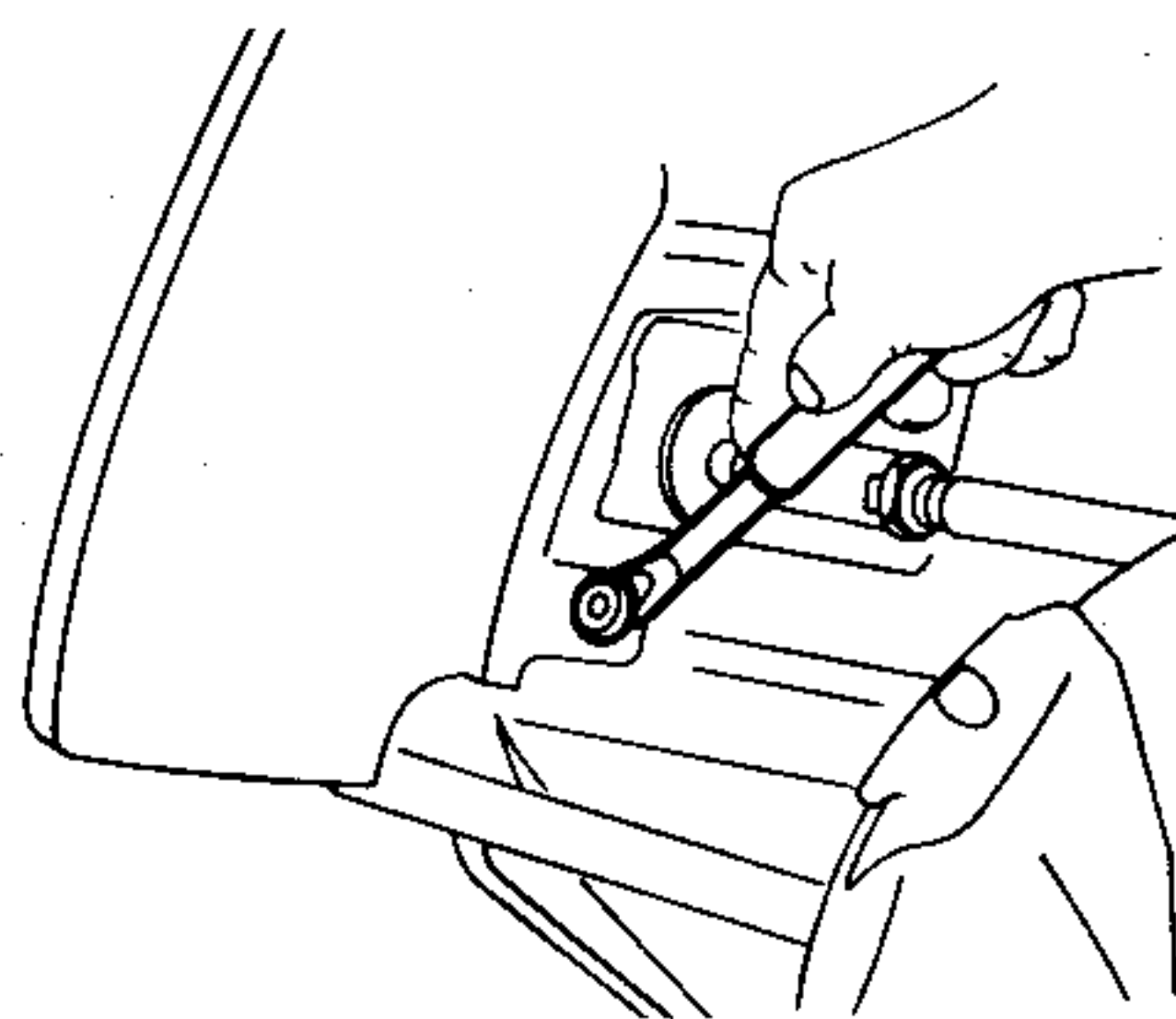

Edging (item 1 of exploded view) is pushed in place on bumper sheet panel with its edge inserted under the apron.

4. Remove the apron.
5. Install the apron by reversing the order of removal.

COWL TOP COVER

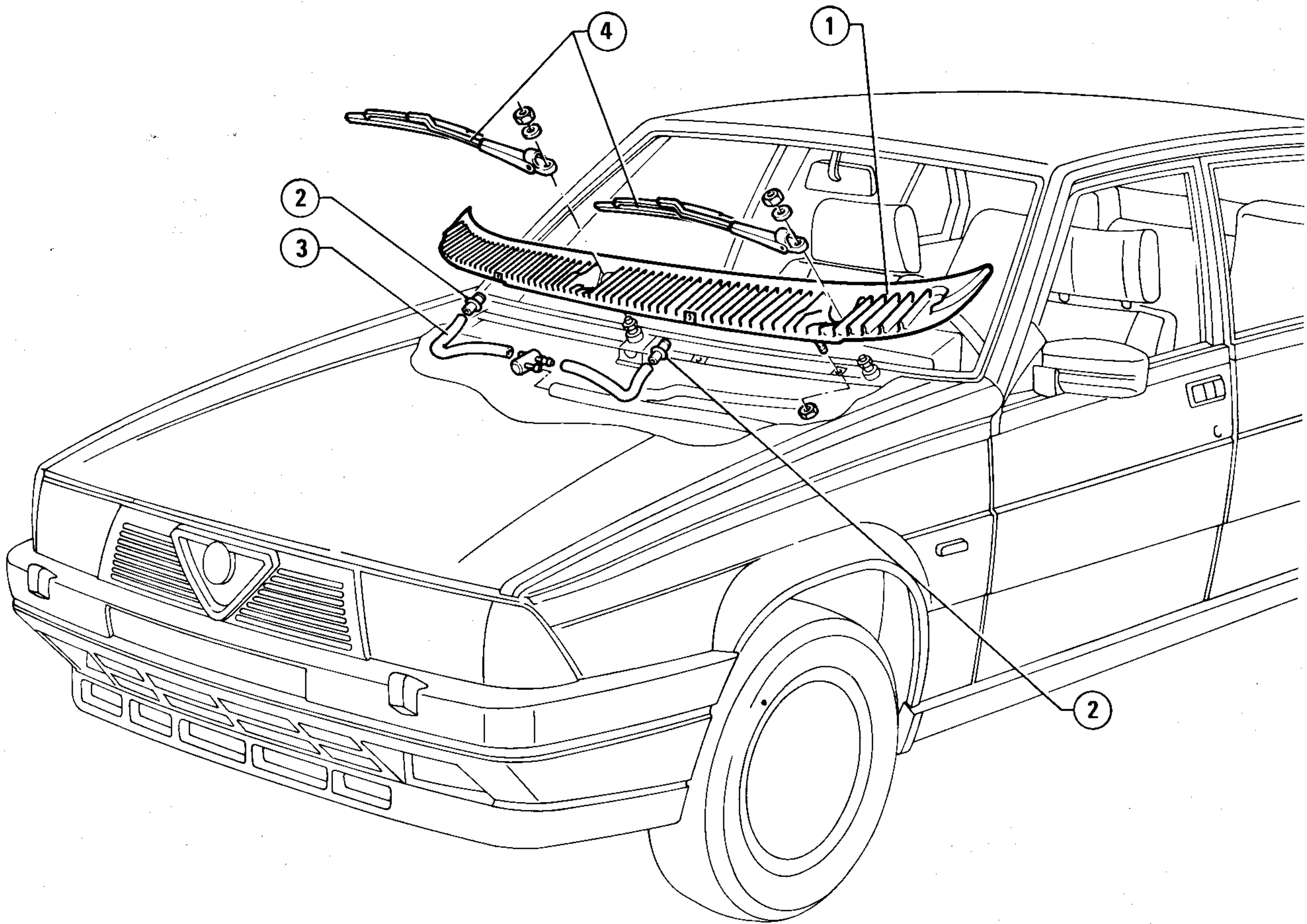

- 1 Cowl top cover
- 2 Spray nozzles
- 3 Windscreen washer piping
- 4 Wiper arms

REMOVAL AND INSTALLATION

1. Lift the protective covers of the nuts securing the windscreen wiper arms, unscrew the related screws, and remove them.
2. Open the bonnet and support it with the special rod.
3. Withdraw the two delivery hoses (1) to spray nozzles (2).

CAUTION:

Two operators are needed for this operation.

4. Unscrew the four bolts securing the knuckle of bonnet hinges; withdraw the bolts, lower the bonnet, and move it forwards.

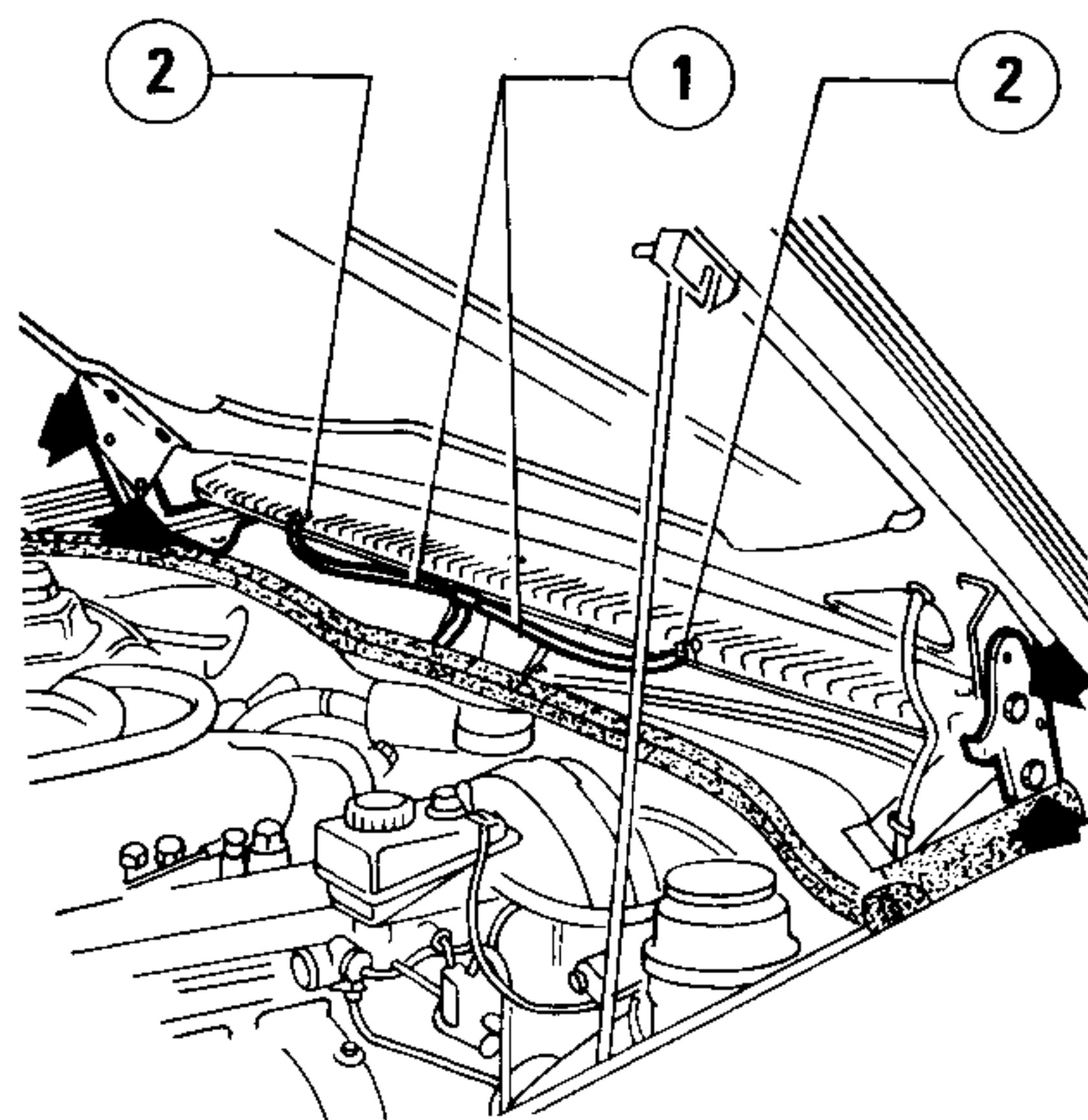

- 1 Piping
- 2 Spray nozzles

5. Remove the cowl top cover by releasing the five pins, which have been pushed into place, securing it to the body.
6. If required remove the spray nozzles, that have been pushed into place, from the cowl top cover.
7. Install the cowl top cover by reversing the order of removal.

SERVICE DATA AND SPECIFICATIONS

GENERAL SPECIFICATIONS

SEALING AND FIXING AGENTS

Application	Name	Quantity
Body primer } Window primer } Glue }	Kit: ALFA ROMEO Std. No. 162.00.76.001.99	— — —

SPECIAL SERVICE TOOLS

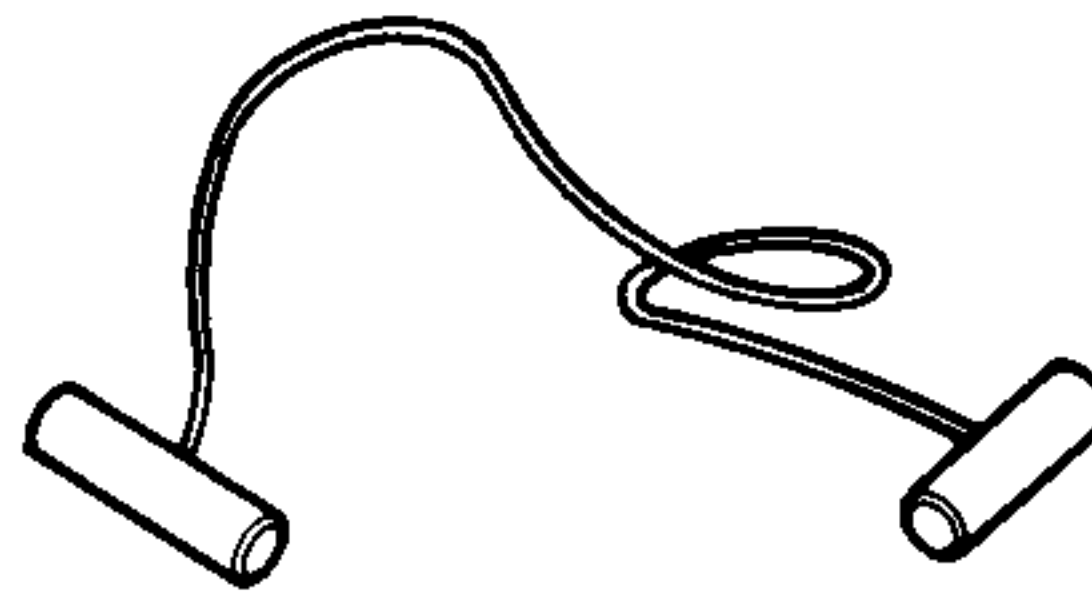
Tool number	Tool name	Page ref.
A.9.0060	Tool for detaching front and rear windows 	75-6 75-7